

a) Part as supplied.

KTKK 1950-1958

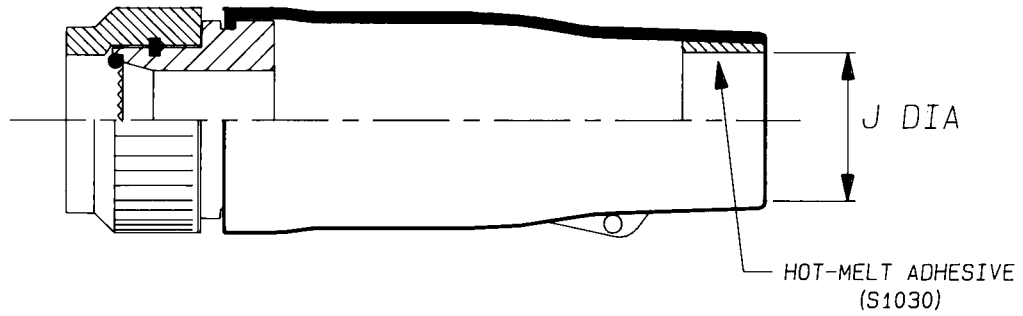

b) Part after unrestricted recovery.

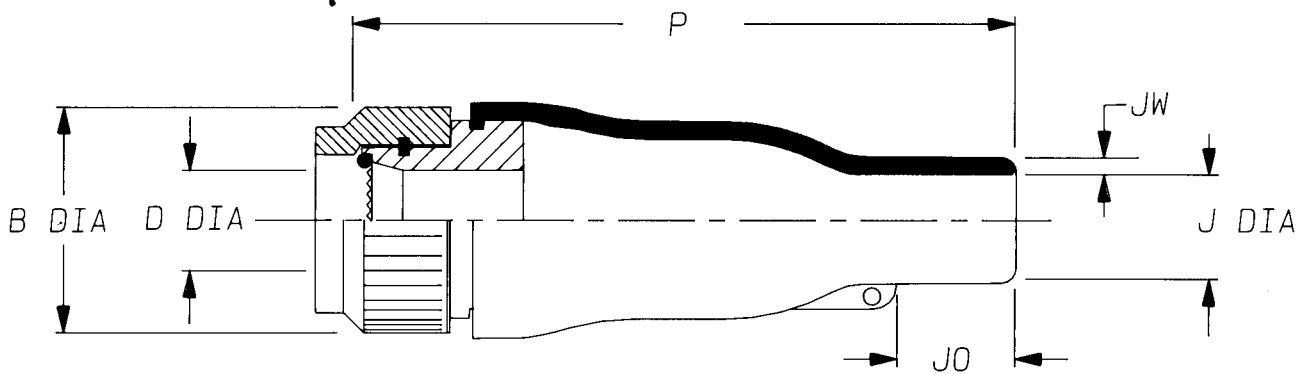

Raychem connector code: - 40

Connector series: - MIL-C-38999 SERIES 3 & 4

Adaptor Series: - 208M7**-19-B**-K-NS

Moulded Part Material: - -100

Kits to include cleaning tissue, 1 piece 100 grit emery cloth.

Kit to be used in conjunction with installation guide for straight assemblies.

Dimensions (in millimetres.)

Part No.	SHELL SIZE	B	D	J		P	JO	JW
		DIA MAX	DIA MIN	MIN a	MAX b	±10% b	REF b	±30% b
KTKK 1950	A	19.2	6.2	11	5.6	50	9	0.5
KTKK 1951	B	21.7	9.3	15	5.9	67	12	1.0
KTKK 1952	C	25.5	12.9	19	7.1	79	17	1.0
KTKK 1953	D	29.3	14.1	19	7.1	79	17	1.0
KTKK 1954	E	31.9	18.8	24	8.4	92	20	1.0
KTKK 1955	F	35.7	18.8	24	8.4	92	20	1.0
KTKK 1956	G	38.2	23.6	31	9.9	111	21	1.0
KTKK 1957	H	42.0	23.6	31	9.9	111	21	1.0
KTKK 1958	J	44.6	30.9	37	15.7	142	39	1.5

Copyright (!)

Urheberrechte

The copyright in this drawing is the property of Raychem Ltd. The drawing is issued on condition that it is not copied, reproduced or disclosed to a third party, either in whole or in part without the prior written consent of Raychem Ltd.

Drawn A.LILLEY. Checked *HL* Issue 3 Date June 1995

Conforms to ISO Recommendations
3rd Angle Projection
Not to Scale

Approval

Design

AAPJ

MKTG.

ML

Q.C.

ML

