

REVISIONS					
P	LTR	DESCRIPTION	DATE	DWN	APVD
	A	INITIAL RELEASE	23SEP2015	DL	CW

NOTES:

- 1 SET OF PRODUCT (K0000000057-000) CONTAIN:  
 1 PC ITEM No.1 (T2040323201-000) AND 1PC ITEM No.2 (T2040323101-000) ARE IN ONE BAG WITH ASSEMBLY STAGE;  
 1 PC ITEM No.3 (T2040163201-000) AND 1PC ITEM No.4 (T2040163101-000) ARE IN ONE BAG WITH ASSEMBLY STAGE;  
 1 PC ITEM No.5 (T1410322000-000) IN ONE BAG;  
 1 PC ITEM No.6 (T1210320140-000) IN ONE BAG;
- 1 SET OF PRODUCT (K0000000057-000) IS PUT IN ONE INNER-BOX;  
 10 INNER-BOXES IN ONE CARTON.

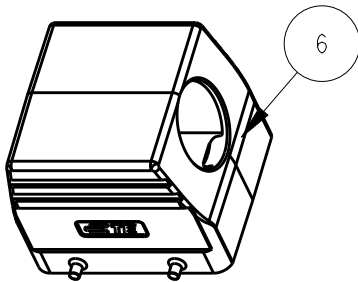

SCALE 3:10

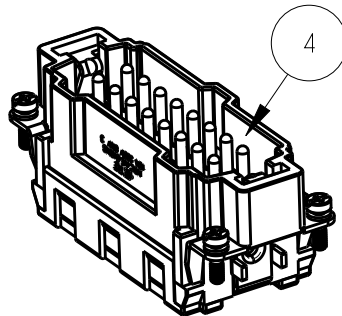

SCALE 3:5

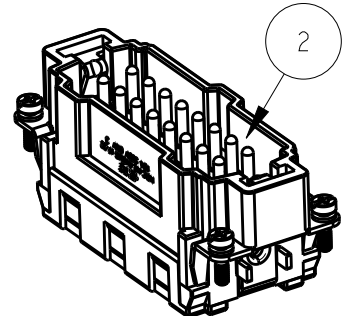

SCALE 3:5

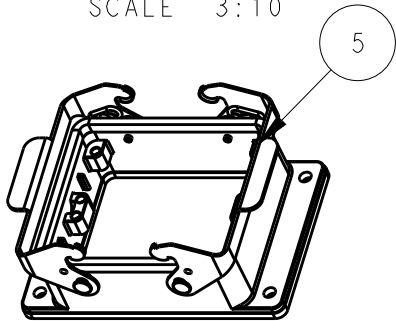

SCALE 3:10

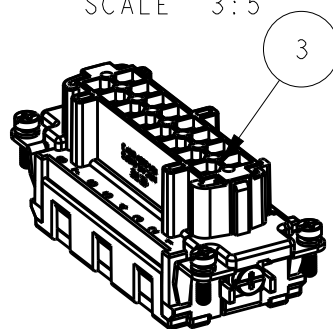

SCALE 3:5

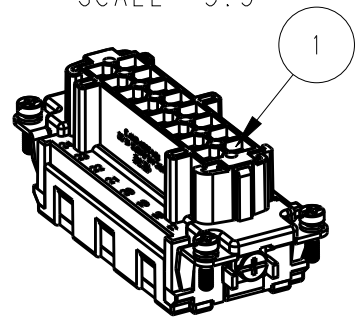

SCALE 3:5

K0000000057-000				
ITEM No.	PART NUMBER	PART DESCRIPTION	PART TYPE	Q'TY
6	T1210320140-000	HOOD	H32B-TS-M40	1
5	T1410322000-000	HOUSING	H32B-AG	1
4	T2040163101-000	MALE INSERT	HE-016-MS	1
3	T2040163201-000	FEMALE INSERT	HE-016-FS	1
2	T2040323101-000	MALE INSERT	HE-016-MS (17-32)	1
1	T2040323201-000	FEMALE INSERT	HE-016-FS (17-32)	1

20

RELEASED FOR PUBLICATION

ALL RIGHTS RESERVED.

THIS DRAWING IS UNPUBLISHED.

BY -

© COPYRIGHT 20

DIMENSIONS: mm	DWN DAVID LI	23SEP2015	MATERIAL TBD	FINISH -
	CHK CHRIS WANG	23SEP2015		
TOLERANCES UNLESS OTHERWISE SPECIFIED:	APVD XU XIANG	23SEP2015		
	0 PLC ±-	PRODUCT SPEC	SIZE A4	CAGE CODE -
1 PLC ±-	APPLICATION SPEC	RESTRICTED TO		
2 PLC ±-	WEIGHT	-	SCALE 1:1	SHEET 1 OF 1
3 PLC ±-	CUSTOMER DRAWING		REV A	
4 PLC ±-				
ANGLES ±-				

