

REVISIONS					
P	LTR	DESCRIPTION	DATE	DWN	APVD
	A	INITIAL RELEASE	02SEP2015	DL	CW

NOTES:

- 1 SET OF PRODUCT (K0000000037-000) CONTAIN:
 1 PC ITEM No.1 (T2040162201-000) AND 1PC ITEM No.2
 (T2040162101-000) ARE IN ONE BAG WITH ASSEMBLY STAGE;
 1 PC ITEM No.3 (T1440162121-000) IN ONE BAG;
 1 PC ITEM No.4 (T1210160121-000) IN ONE BAG;
- 1 SET OF PRODUCT (K0000000037-000) IS PUT IN ONE INNER-BOX;
 20 INNER-BOXS IN ONE CARTON.

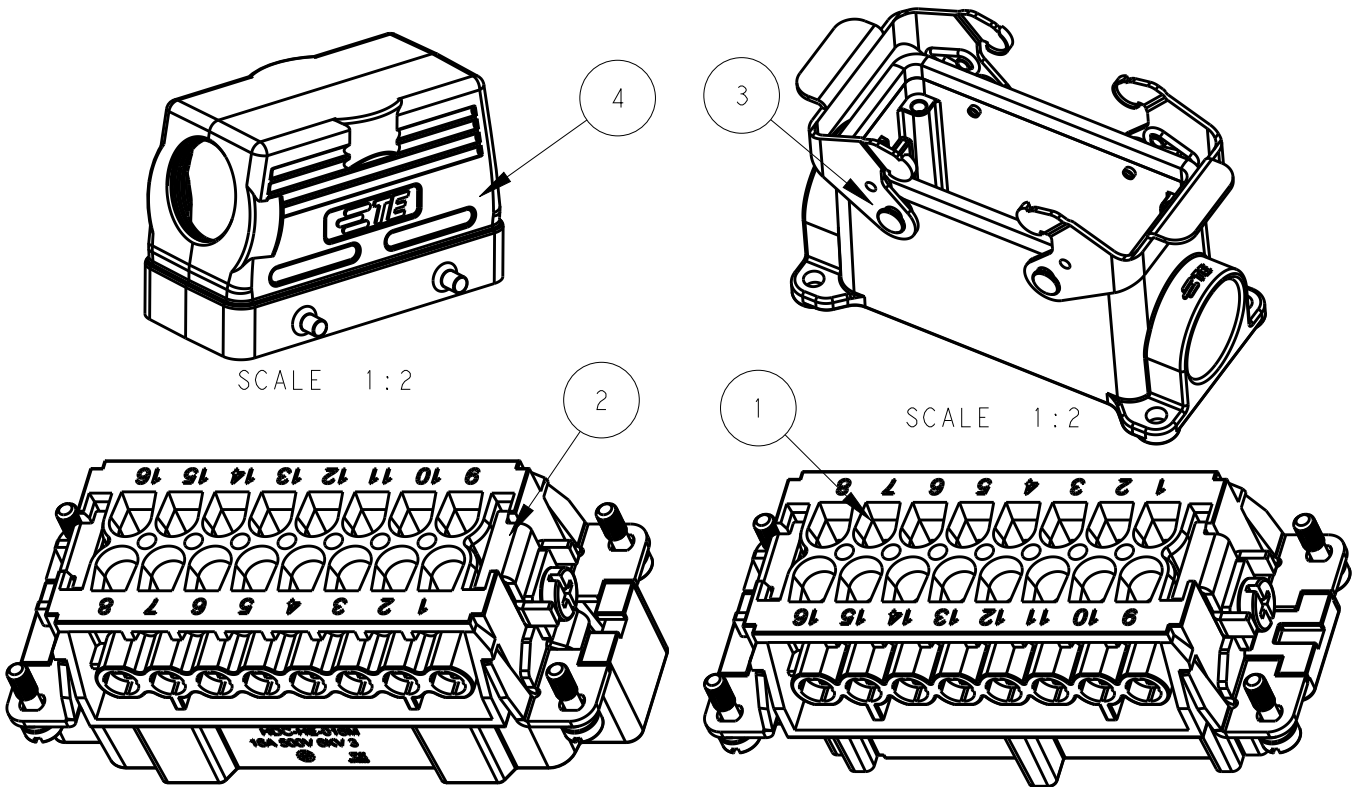

ITEM No.	PART NUMBER	PART DESCRIPTION	PART TYPE	Q'TY
	K0000000037-000			
4	T1210160121-000	HOOD	H16B-TS-PG21	1
3	T1440162121-000	HOUSING	H16B-SGR-PG21	1
2	T2040162101-000	MALE INSERT	HE-016-M	1
1	T2040162201-000	FEMALE INSERT	HE-016-F	1

20
 RELEASED FOR PUBLICATION
 ALL RIGHTS RESERVED.
 BY -
 THIS DRAWING IS UNPUBLISHED.
 COPYRIGHT 20

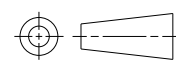
DIMENSIONS:		DWN	02SEP2015	MATERIAL	TBD	FINISH	-
mm		DAVID LI		 TE Connectivity			
TOLERANCES UNLESS OTHERWISE SPECIFIED:		CHK	02SEP2015				
0 PLC	±-	CHRIS WANG		NAME HDC-HE-016.2 KITS			
1 PLC	±-	APVD	02SEP2015				
2 PLC	±-	XU XIANG		SIZE A4 CAGE CODE - DRAWING NO C-K0000000037000 RESTRICTED TO -			
3 PLC	±-	PRODUCT SPEC	-				
4 PLC	±-	APPLICATION SPEC	-	SCALE 1:1 SHEET 1 OF 1 REV A			
ANGLES	±-	WEIGHT	-				
		CUSTOMER DRAWING					