

P	LTR	DESCRIPTION	DATE	DWN	APVD
	B	INITIAL RELEASE	20OCT2020	GK	MN

LABEL AND LINER DESIGN

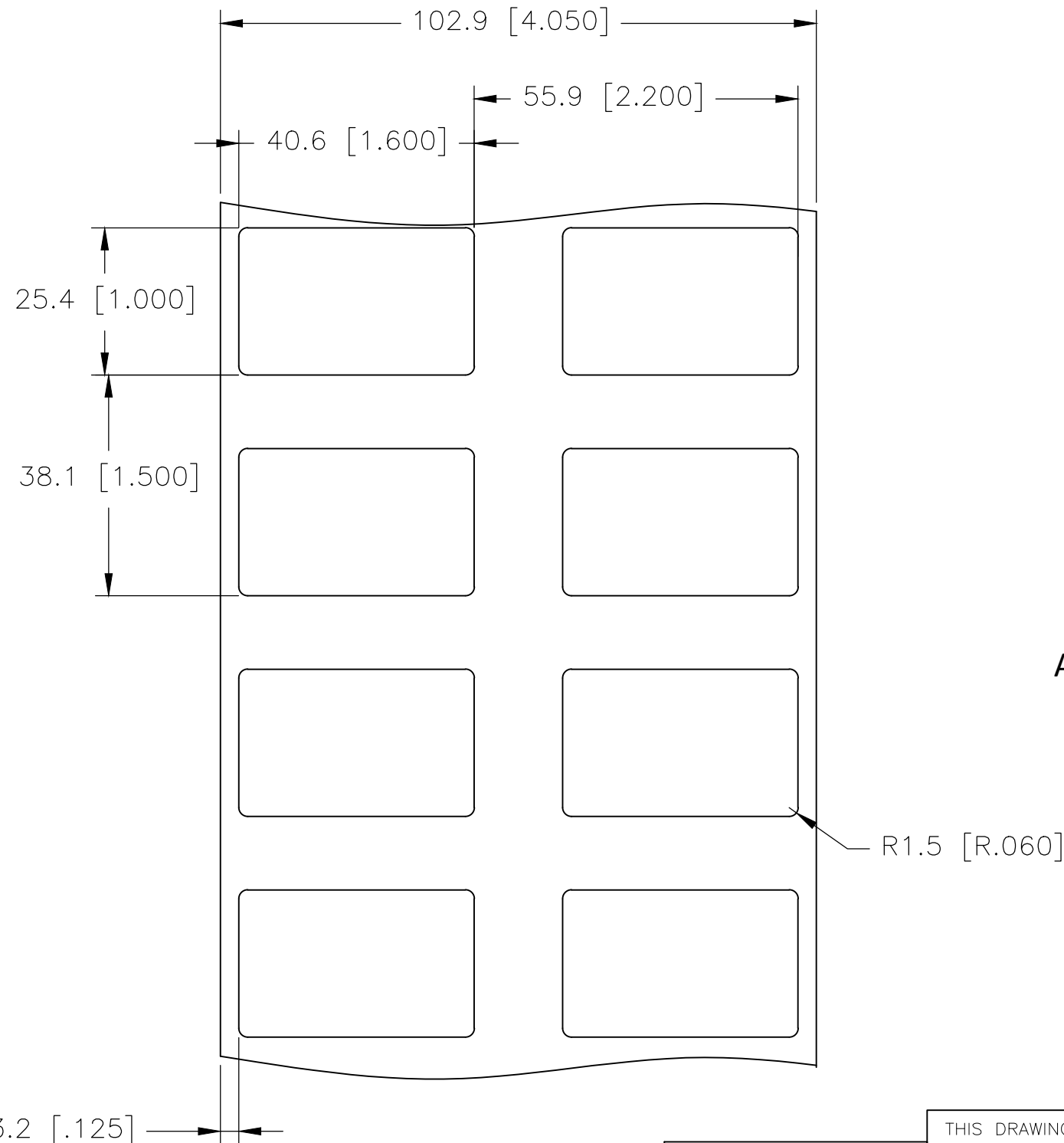

PRESENTATION

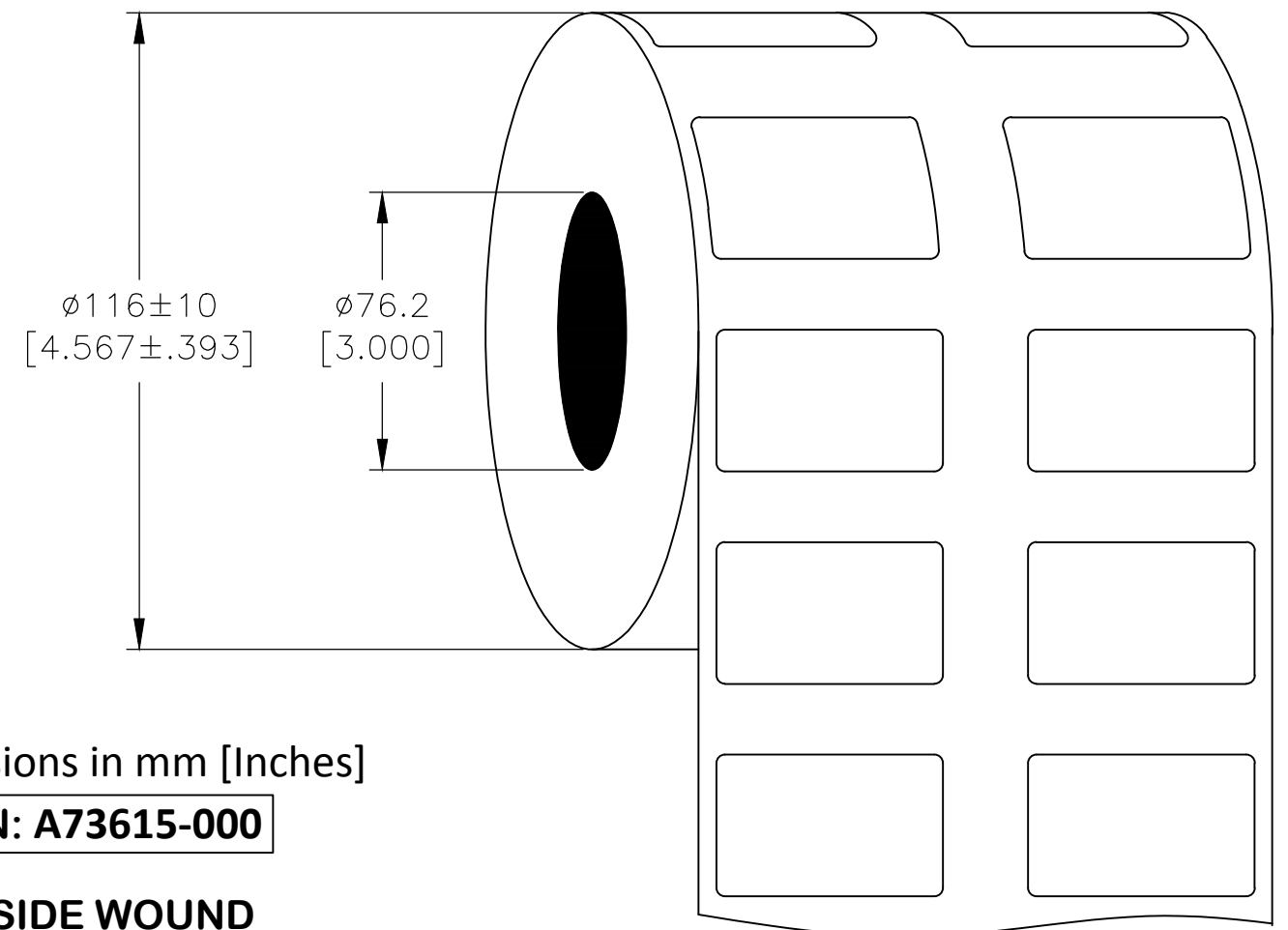

All dimensions in mm [Inches]

TE PN: A73615-000

**OUTSIDE WOUND
LABEL ACROSS: 2
PER ROLL QTY: 1500**

MATERIAL	HIGH TACK WHITE POLYESTER
ADHESIVE TYPE	PERMANENT ACRYLIC
LINER	GLASSINE PAPER

TOLERANCES mm [INCH]	
LABEL HEIGHT:	±0.3 [.012]
LABEL WIDTH:	±0.3 [.012]
WEB WIDTH:	±0.8 [.031]
VERTICAL REPEAT:	±0.8 [.031]*
HORIZONTAL REPEAT:	±0.8 [.031]*
PRINT POSITIONING:	±0.8 [.031]*
LEFT MARGIN:	±0.4 [.016]
QUANTITY:	-0 % +2 %
*NON ACCUMULATING	

THIS DRAWING IS A CONTROLLED DOCUMENT.	
DIMENSIONS: mm [INCHES]	TOLERANCES UNLESS OTHERWISE SPECIFIED:
	0 PLC ± -
	1 PLC ± -
	2 PLC ± -
	3 PLC ± -
	4 PLC ± -
ANGLES ± -	± -
MATERIAL SEE TABLE	FINISH -

DWN	20OCT2020
GOPALAKRISHNA HV	
CHK	20OCT2020
MIKE NUTTALL	
APVD	20OCT2020
MIKE NUTTALL	
PRODUCT SPEC	
TTDS-076	
APPLICATION SPEC	
WEIGHT	0.121g

TE Connectivity		NAME	
		HW - HIGH TACK WHITE POLYESTER LABELS	
SIZE	CAGE CODE	DRAWING NO	RESTRICTED TO
A3	C2290	C-HW-406254-1.5-9	-
CUSTOMER DRAWING		SCALE	SHEET
		NTS	1 OF 1
		REV	B