

P	LTR	DESCRIPTION	DATE	DWN	APVD
	B	INITIAL RELEASE	22SEP2020	GK	MN

LABEL AND LINER DESIGN

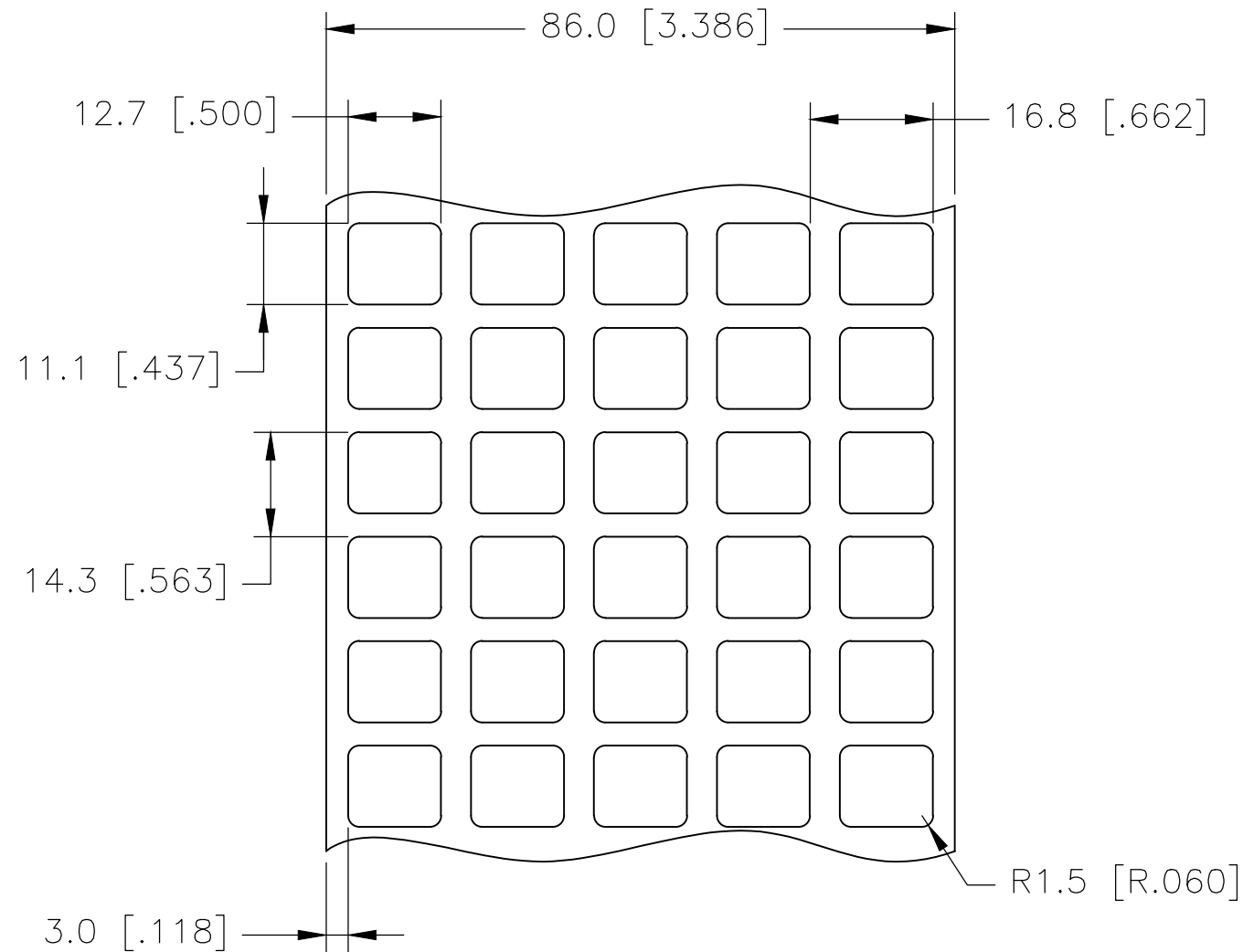

PRESENTATION

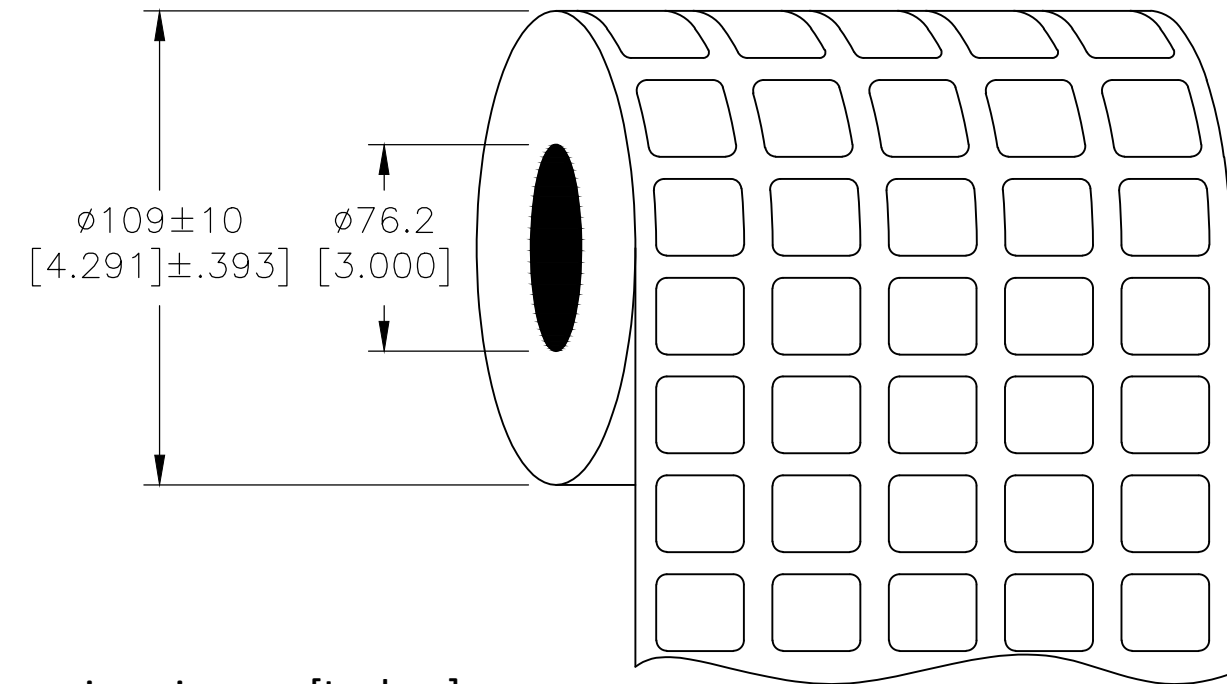

All dimensions in mm [Inches]

TE PN: D98219-000

**OUTSIDE WOUND
LABEL ACROSS: 5
PER ROLL QTY: 10000**

MATERIAL	HIGH TACK METALIZED POLYESTER
ADHESIVE TYPE	PERMANENT ACRYLIC
LINER	GLASSINE PAPER

TOLERANCES mm [INCH]	
LABEL HEIGHT:	±0.3 [.012]
LABEL WIDTH:	±0.3 [.012]
WEB WIDTH:	±0.8 [.031]
VERTICAL REPEAT:	±0.8 [.031]*
HORIZONTAL REPEAT:	±0.8 [.031]*
PRINT POSITIONING:	±0.8 [.031]*
LEFT MARGIN:	±0.4 [.016]
QUANTITY:	-0 % +2 %
*NON ACCUMULATING	

THIS DRAWING IS A CONTROLLED DOCUMENT.	
DIMENSIONS: mm [INCHES]	TOLERANCES UNLESS OTHERWISE SPECIFIED:
	0 PLC ± -
	1 PLC ± -
	2 PLC ± -
	3 PLC ± -
	4 PLC ± -
MATERIAL SEE TABLE	FINISH -

DWN	22SEP2020
GOPALAKRISHNA HV	
CHK	22SEP2020
MIKE NUTTALL	
APVD	22SEP2020
MIKE NUTTALL	
PRODUCT SPEC	TTDS-075
APPLICATION SPEC	-
WEIGHT	0.016g

TE Connectivity		NAME	
		HM - HIGH TACK METALIZED POLYESTER LABELS	
SIZE	CAGE CODE	DRAWING NO	RESTRICTED TO
A3	C2290	G-HM-127111-10-8A	-
CUSTOMER DRAWING		SCALE	SHEET
		NTS	1 OF 1
		REV	B