

CUSTOMER DRAWING

REV:
A

DATE:
APR 27, 2015

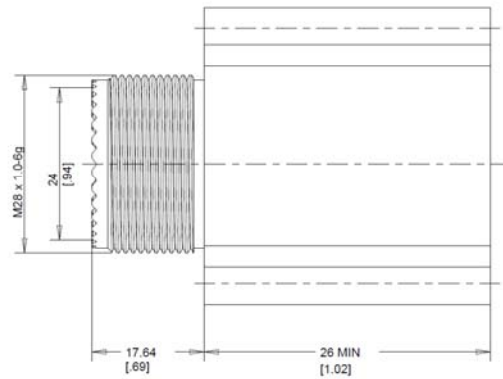
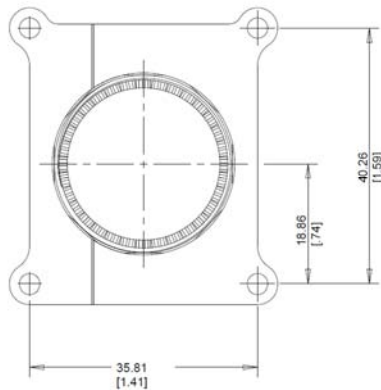
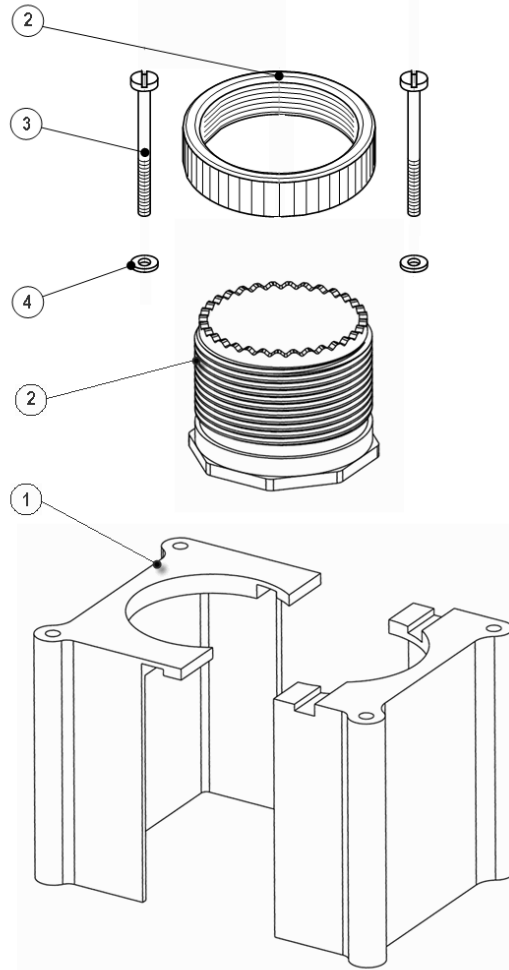

TOLERANCES
1 FIG = ±0.25 [0.010"]

KIT DESCRIPTION

© 2015 Tyco Electronics Corporation. All rights reserved.

		Raychem Adapters		TITLE: HEXASHIELD ADAPTOR FOR ARINC 600 SIZE 02 - CAVITY A SIZE 19 OUTLET		
				DOCUMENT NO. HEXA6-AY-00-02-19-105		
DRAWN: NSWATKO	DATE: 04/27/2015	CAGE CODE: 06090	REVISED PER ECO-15-006473	APPROVED: I MYONG	SCALE: NONE	SHEET: 1 OF 2

If this document is printed it becomes uncontrolled. Check for the latest.

CUSTOMER DRAWING

REV:
A

DATE:
APR 27, 2015

ITEM	QTY	DESCRIPTION	MATERIAL
1	1	HOUSING	
	1	SUPPORT – LEFT HAND	ALUMINIUM ALLOY
	1	SUPPORT – RIGHT HAND	ALUMINIUM ALLOY
2	1	OUTLET ASSEMBLY – CODE 40 (SS19)	ALUMINIUM ALLOY
3	4	PAN HEAD SCREW - 4-40 UNC x 1.25" LONG	STAINLESS STEEL - PASSIVATED
4	4	WAVE WASHER	STAINLESS STEEL - PASSIVATED

PART NUMBERING

HEXA6 - A B - 00 - 02 - 19 - 105

- CONNECTOR CODE NUMBER _____
HEXA6 = ARINC 600 CONNECTOR
- MATERIAL CODE: _____
ALUMINIUM ALLOY
- PLATING CODE: _____
B = CADMIUM OLIVE DRAB TO SAE-AMS-QQ-P-416
C = ELECTROLESS NICKEL TO SAE-AMS-MIL-C-26074
- OUTLET STYLE _____
00 = STRAIGHT
- ORDER NUMBER _____
02 = SIZE 2 (CAVITY A)
- ORDER NUMBER (FOR MATING ACCESSORY) _____
- ASSEMBLY SPECIFIC ORDER NUMBER _____

APPLICATION

- This adaptor assembly is designed to be mounted on the following connectors:

ARINC 600 Plug, Shell Size 2 – Cavity A

INSTALLATION

- See Installation Procedures RPIP-696-02 and -04 for basic instructions.

PACKAGING

- All assemblies are supplied boxed and labelled.

NOTES!

1. Assembly is to be permanently marked with Code Identity Number and Part Number.
(e.g. 06090 HEXA6-AB-00-02-19-105)

© 2015 Tyco Electronics Corporation. All rights reserved.

		<h3>Raychem Adapters</h3>		TITLE: HEXASHIELD ADAPTOR FOR ARINC 600 SIZE 02 - CAVITY A SIZE 19 OUTLET		
UNLESS OTHERWISE SPECIFIED DIMENSIONS ARE IN MILLIMETERS. INCH DIMENSIONS ARE SHOWN IN BRACKETS		This drawing and information set forth hereon is the property of Tyco Electronics and is to be held in trust and confidence. Publication, duplication, disclosure or use for any other purpose not expressly authorized in writing by Tyco Electronics is prohibited.		DOCUMENT NO. HEXA6-AY-00-02-19-105		
DRAWN: NSWATKO	DATE: 04/27/2015	CAGE CODE: 06090	REVISED PER ECO-15-006473	APPROVED: I MYONG	SCALE: NONE	SHEET: 2 OF 2

If this document is printed it becomes uncontrolled. Check for the latest.