

REVISIONS					
P	LTR	DESCRIPTION	DATE	DWN	APVD
A		INITIAL RELEASE	11JUN2020	AS	LH

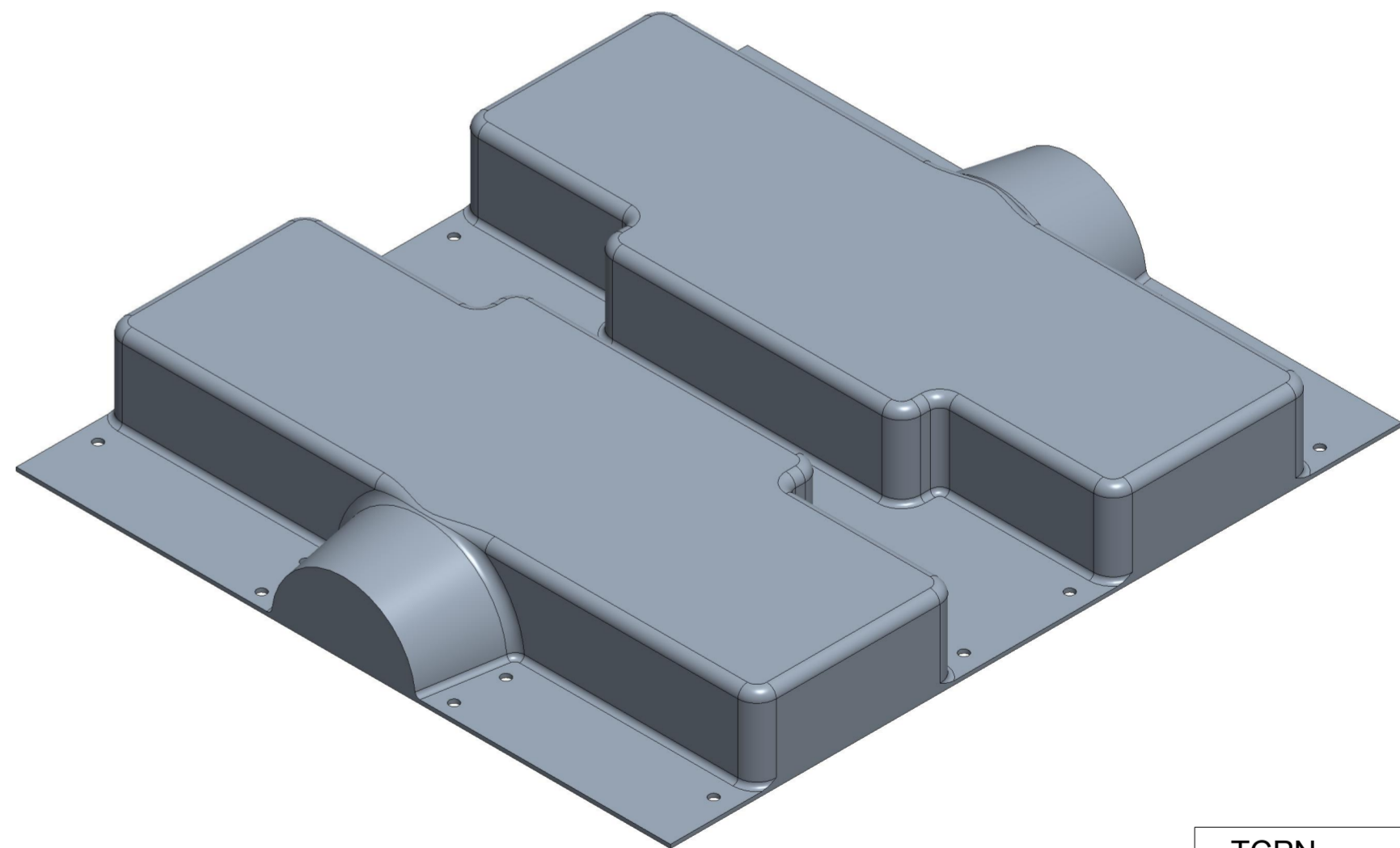
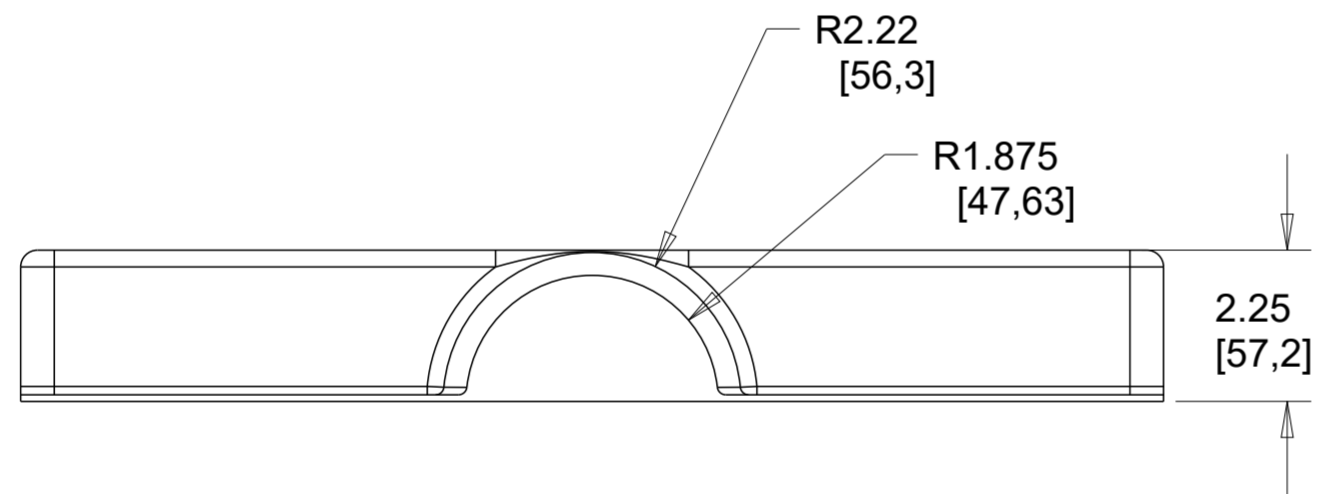
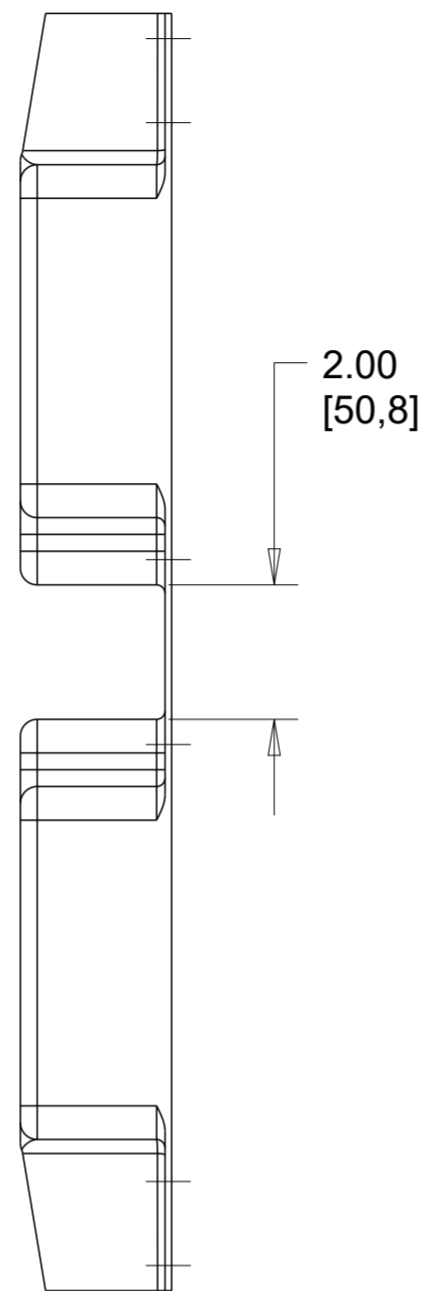
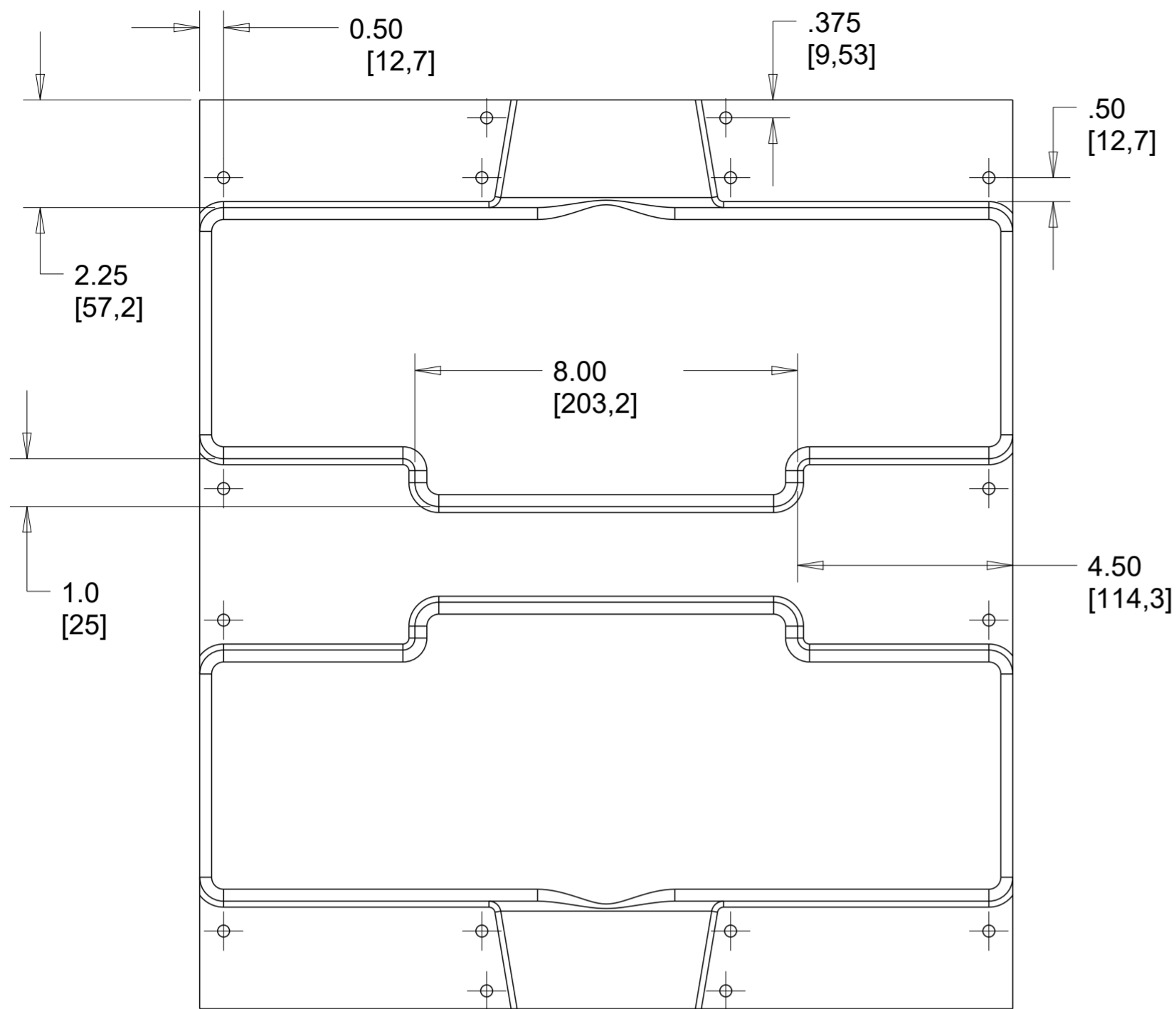

NOTES:

1. PARTS SHALL BE KITTED 3 PIECES PER BOX.
2. PART SHALL BE KITTED WITH QTY 10 BCIC LATCH, PN 607477-000
3. EACH BOX SHALL BE LABELLED WITH DESCRIPTION, LOT NUMBER, PART NUMBER, MANUFACTURING DATE AND QUANTITY

TCPN
209749-000

THIS DRAWING IS A CONTROLLED DOCUMENT.		DWN A. SABARAD 11JUN2020		
DIMENSIONS: INCH(MM)		CHK S. LIGHT 11JUN2020		
TOLERANCES UNLESS OTHERWISE SPECIFIED:		APVD L. HILLER 11JUN2020	NAME BCIC-TR205-L(B3)	
0 PLC ±	1 PLC ±0.1	PRODUCT SPEC	SIZE	CAGE CODE
2 PLC ±0.01	3 PLC ±0.001	APPLICATION SPEC	A2	00779
4 PLC ±0.0001	ANGLES ±	WEIGHT	DRAWING NO	RESTRICTED TO
MATERIAL	FINISH	CUSTOMER DRAWING	C-E00000852	-
-	-	SCALE	NTS	SHEET 1 OF 1
-	-	REV	A	