

REVISIONS				
P	LTR	DESCRIPTION	DATE	APVD
A		INITIAL RELEASE	18APR2020	AS LH

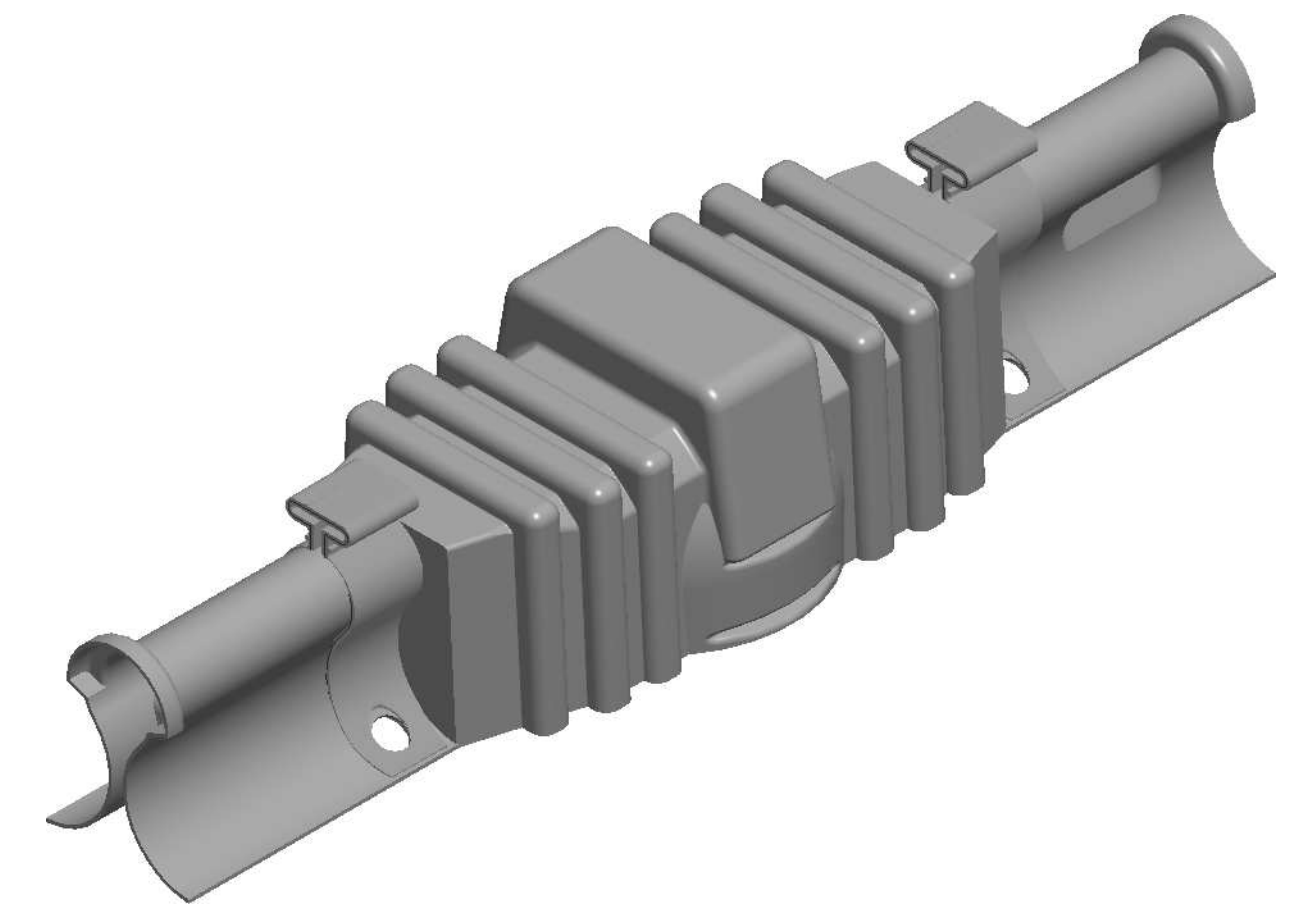
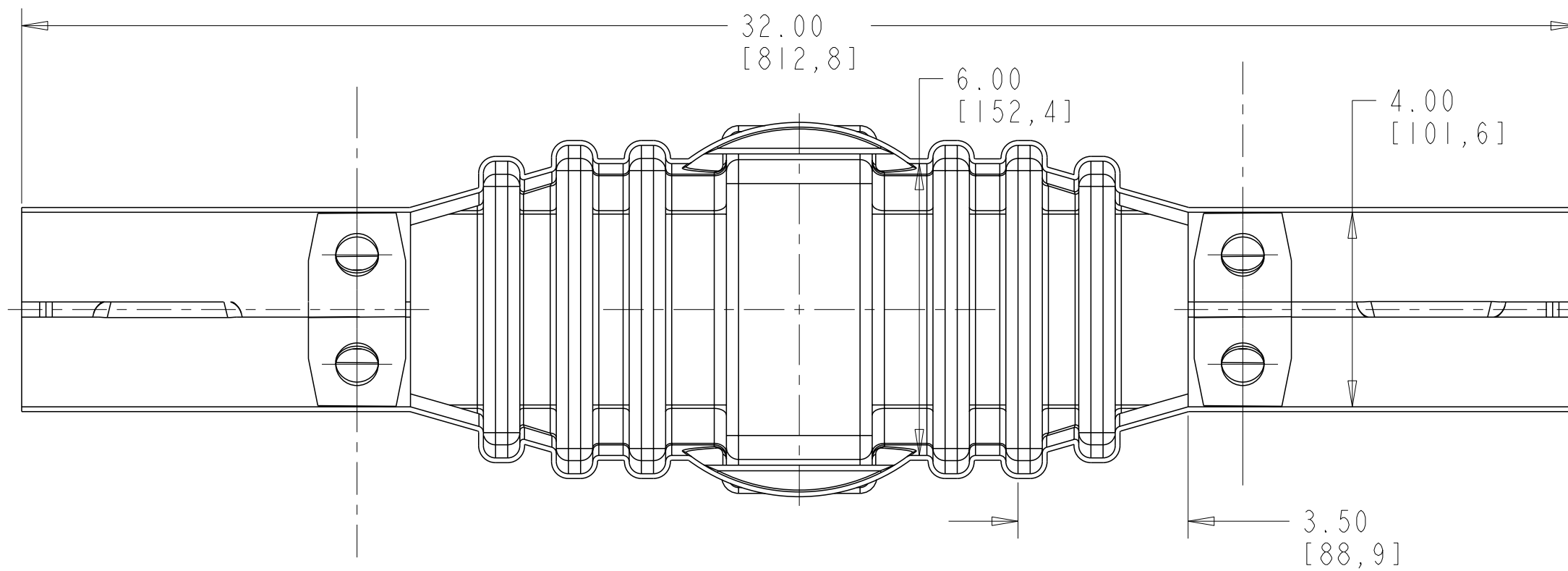
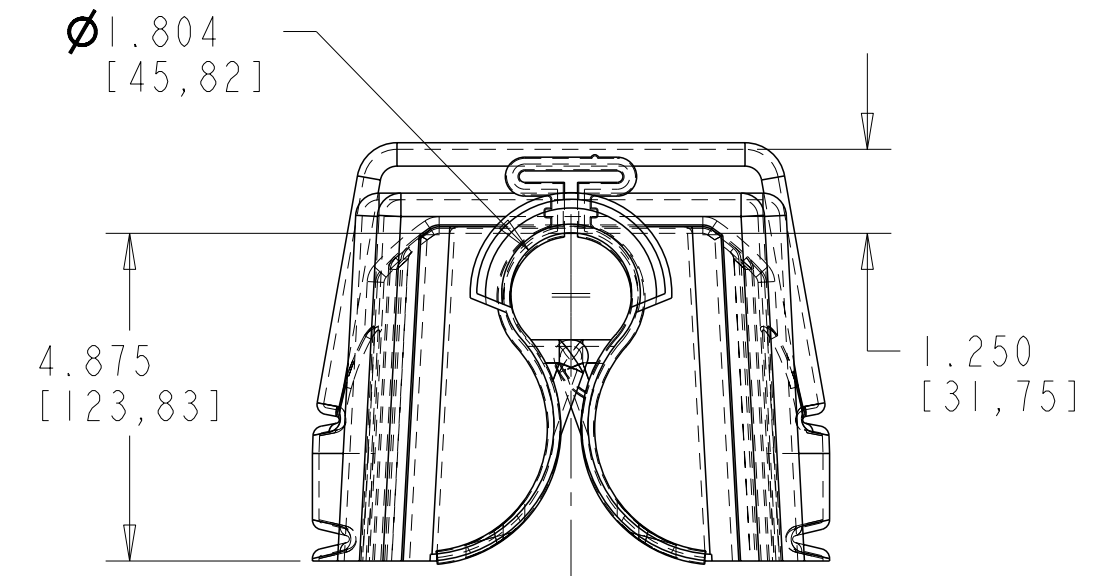
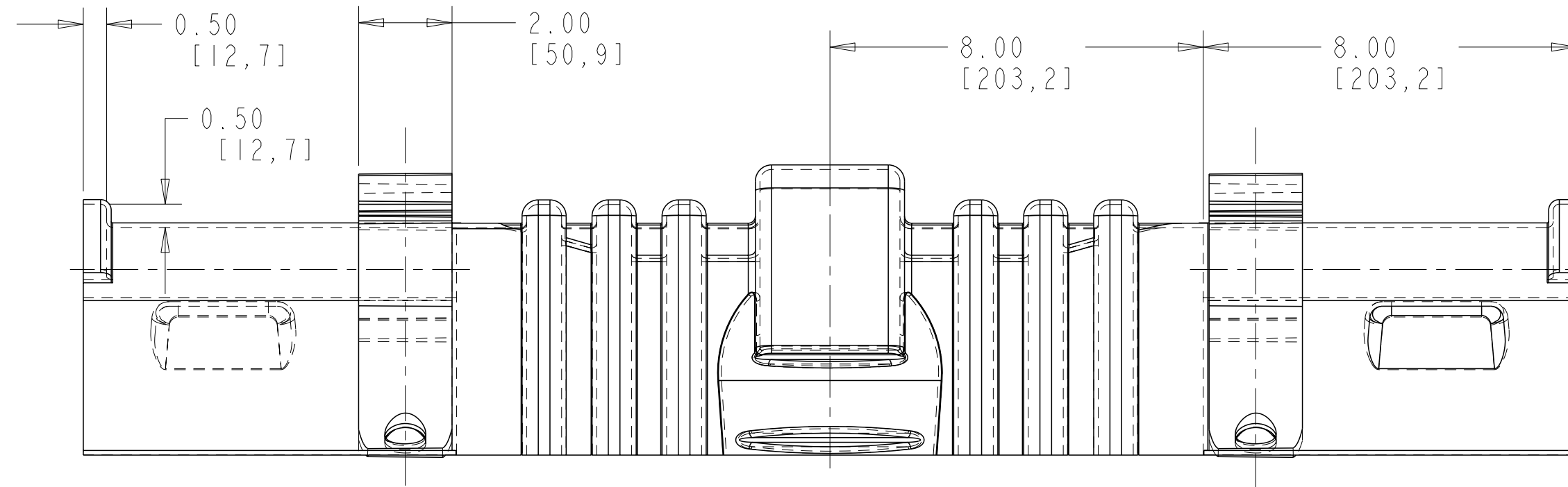

TCPN	DESCRIPTION	PIECES/BOX
E42704-000	BCIC-G-PIN-795-01(B6)	6
C60779-000	BCIC-G-PIN-795-01-24(B3)	3

NOTES:

- PART C60779-000 SHALL BE KITTED WITH QTY 2 BCIC-G-ARM-24-D, PN E30747-000.
- PART SHALL BE KITTED WITH P11-55421
- EACH BOX SHALL BE LABELLED WITH DESCRIPTION, LOT NUMBER, PART NUMBER MANUFACTURING DATE AND QUANTITY.

THIS DRAWING IS A CONTROLLED DOCUMENT.		DWN A. SABARAD 18APR2020	TE Connectivity															
DIMENSIONS: INCH(MM)		CHK S. LIGHT 18APR2020																
TOLERANCES UNLESS OTHERWISE SPECIFIED:		APVD L. HILLER 18APR2020	NAME BCIC-G-PIN-795-01															
<table border="1"> <tr><td>0 PLC</td><td>±</td></tr> <tr><td>1 PLC</td><td>±0.1</td></tr> <tr><td>2 PLC</td><td>±0.01</td></tr> <tr><td>3 PLC</td><td>±0.001</td></tr> <tr><td>4 PLC</td><td>±0.0001</td></tr> <tr><td>ANGLES</td><td>±</td></tr> <tr><td>FINISH</td><td>±</td></tr> </table>		0 PLC	±	1 PLC	±0.1	2 PLC	±0.01	3 PLC	±0.001	4 PLC	±0.0001	ANGLES	±	FINISH	±	PRODUCT SPEC -	SIZE A2	
0 PLC	±																	
1 PLC	±0.1																	
2 PLC	±0.01																	
3 PLC	±0.001																	
4 PLC	±0.0001																	
ANGLES	±																	
FINISH	±																	
MATERIAL -		APPLICATION SPEC -	CAGE CODE 00779	DRAWING NO E00000848														
-		WEIGHT -	RESTRICTED TO -															
-		CUSTOMER DRAWING	SCALE NTS	SHEET 1 OF 1														
-			REV A															