

REVISIONS					
P	LTR	DESCRIPTION	DATE	DWN	APVD
A		INITIAL RELEASE	14JUN2020	AS	LH

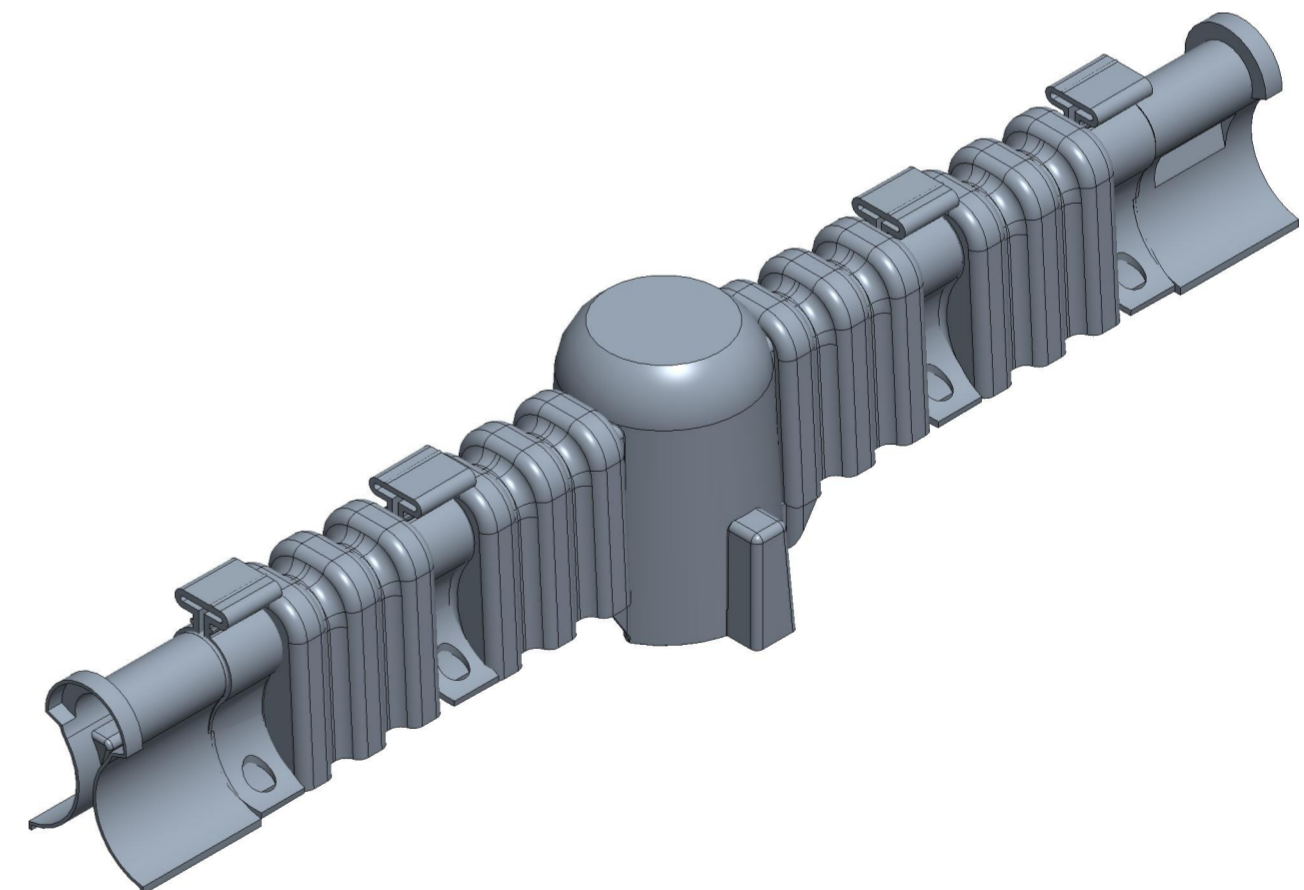
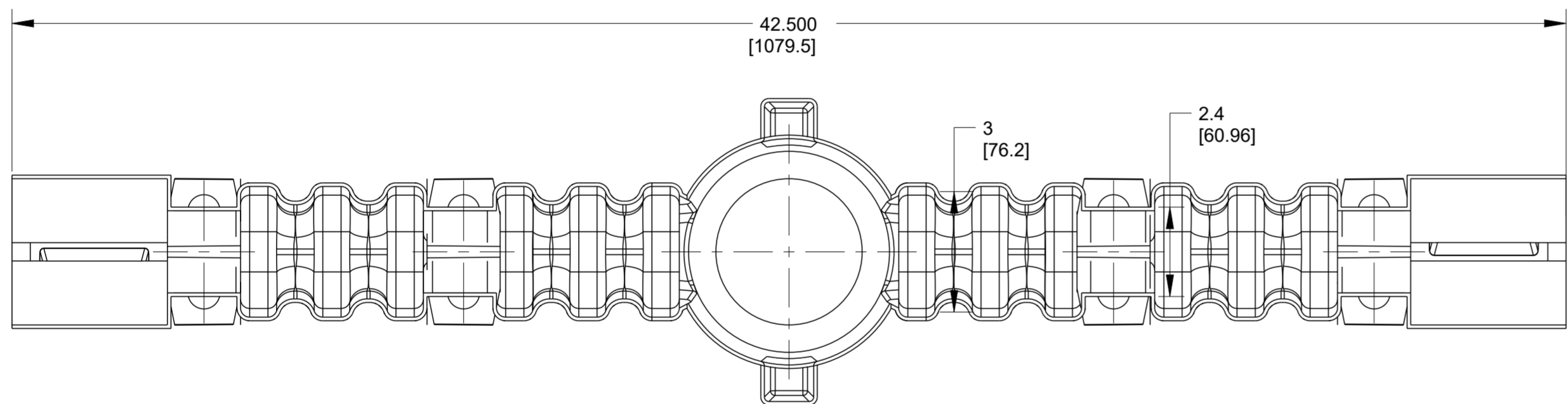
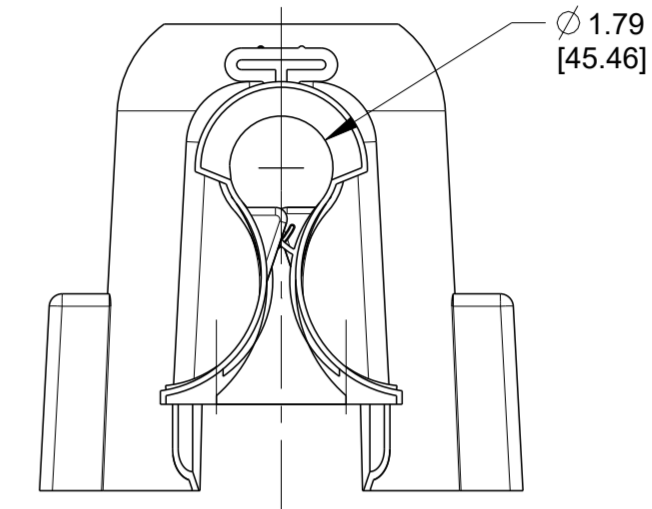
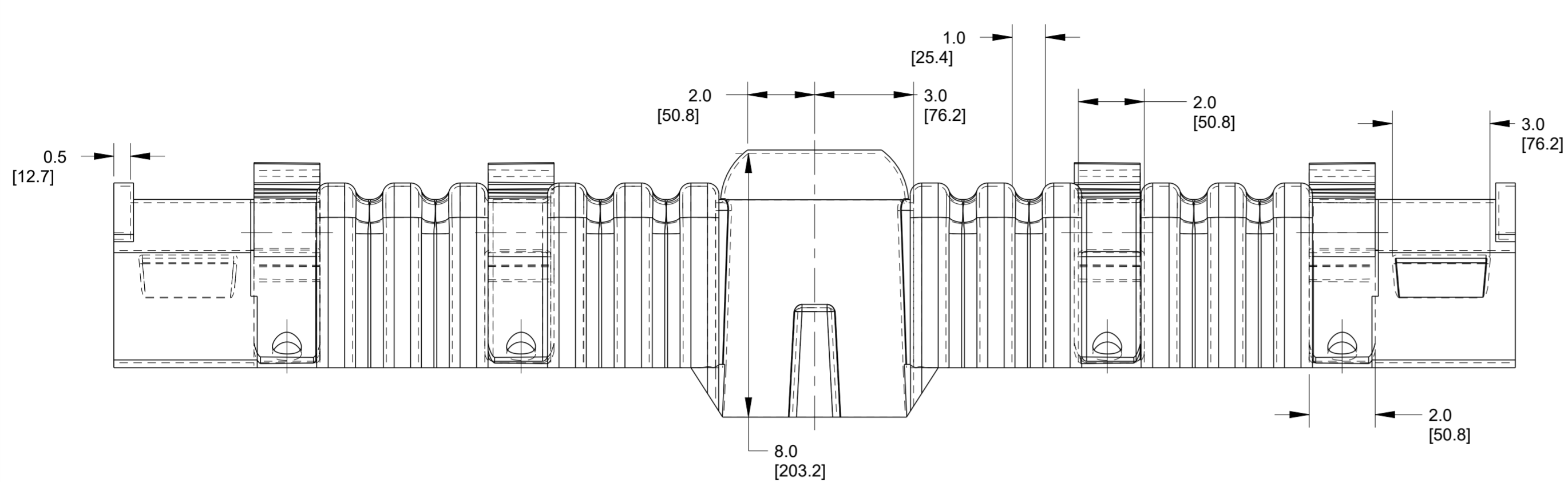

NOTES:

- 1. PARTS TO BE KITTED 6 PIECES PER BOX.
- 2. PARTS SHALL BE KITTED WITH QTY 2 BCIC-RLP-01, PN CS4643-000.
- 3. PARTS SHALL BE KITTED WITH PII-56205
- 4. EACH BOX SHALL BE LABELLED WITH DESCRIPTION, LOT NUMBER, PART NUMBER MANUFACTURING DATE AND QUANTITY.

TCPN  
GF2137-000

THIS DRAWING IS A CONTROLLED DOCUMENT.		DWN A. SABARAD 14JUN2020		
DIMENSIONS: INCH(MM)		CHK S. LIGHT 14JUN2020		
TOLERANCES UNLESS OTHERWISE SPECIFIED:		APVD L. HILLER 14JUN2020	NAME BCIC-G-PIN-5.5D/8-LP(B6)	
0 PLC ±		PRODUCT SPEC	APPLICATION SPEC	
1 PLC ±		WEIGHT		
2 PLC ±		SCALE NTS		
3 PLC ±		SHEET 1 OF 1		
4 PLC ±		REV A		
ANGLES ±		CUSTOMER DRAWING		
FINISH		DRAWING NO E00000846		