

REVISIONS					
P	LTR	DESCRIPTION	DATE	DWN	APVD
A		INITIAL RELEASE	30MAY2020	AS	LH

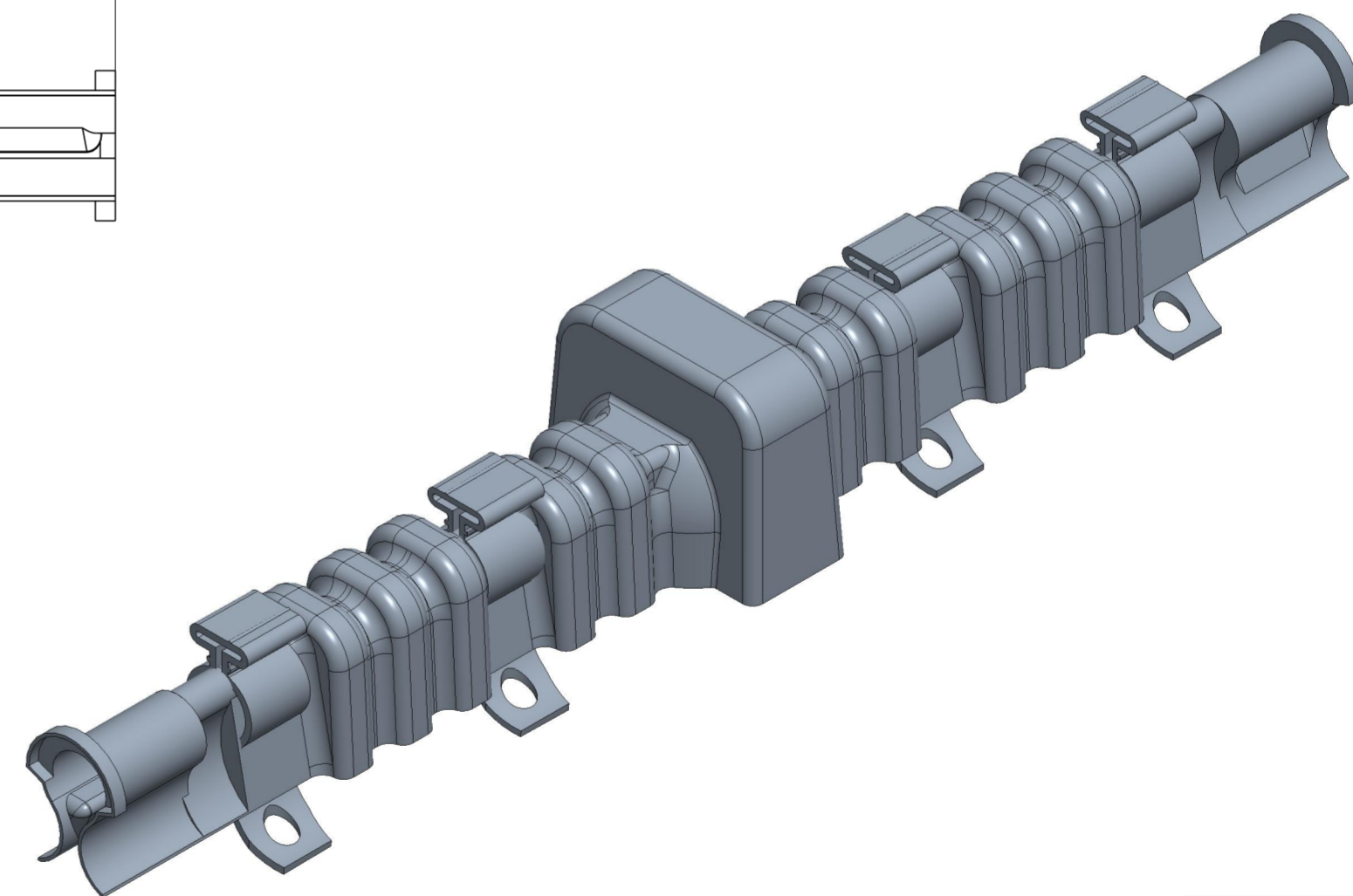
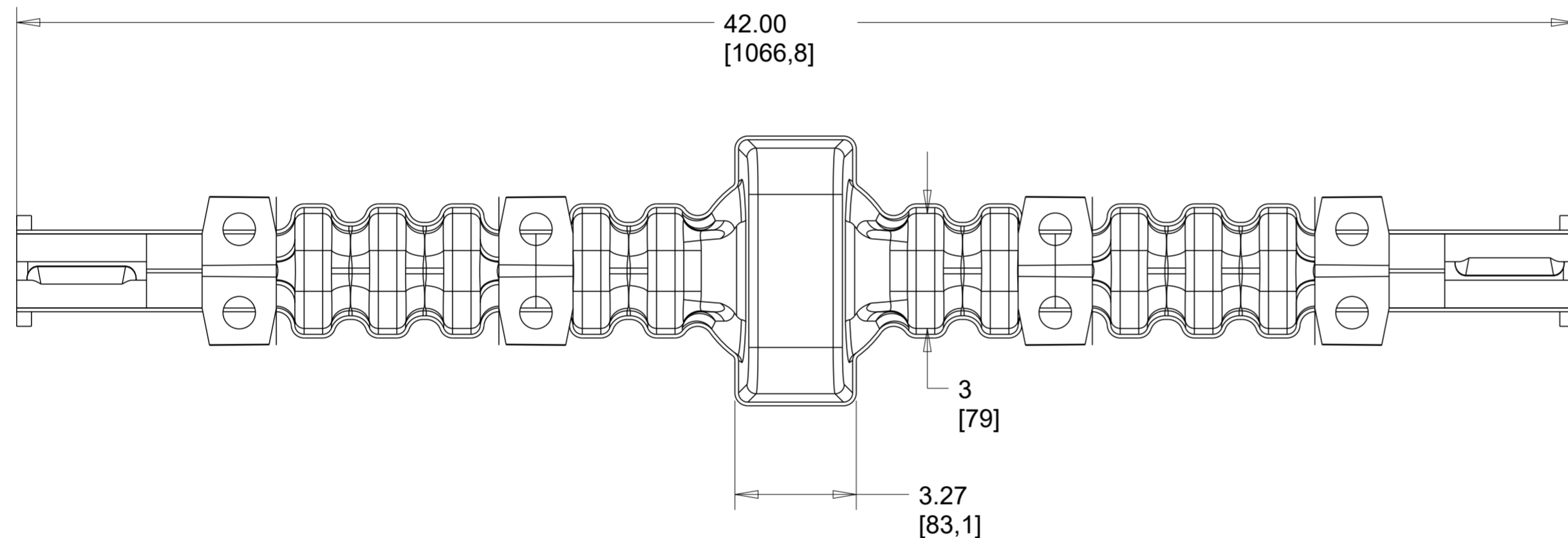
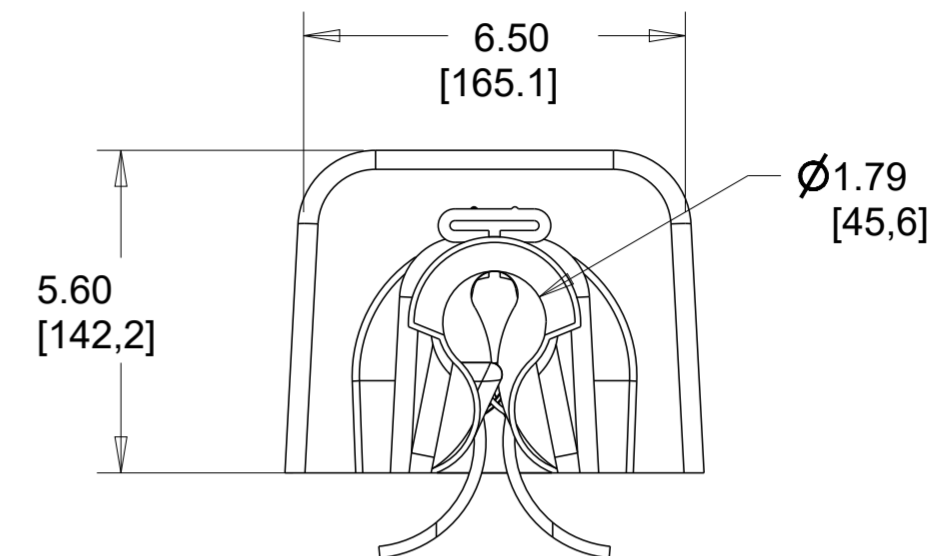
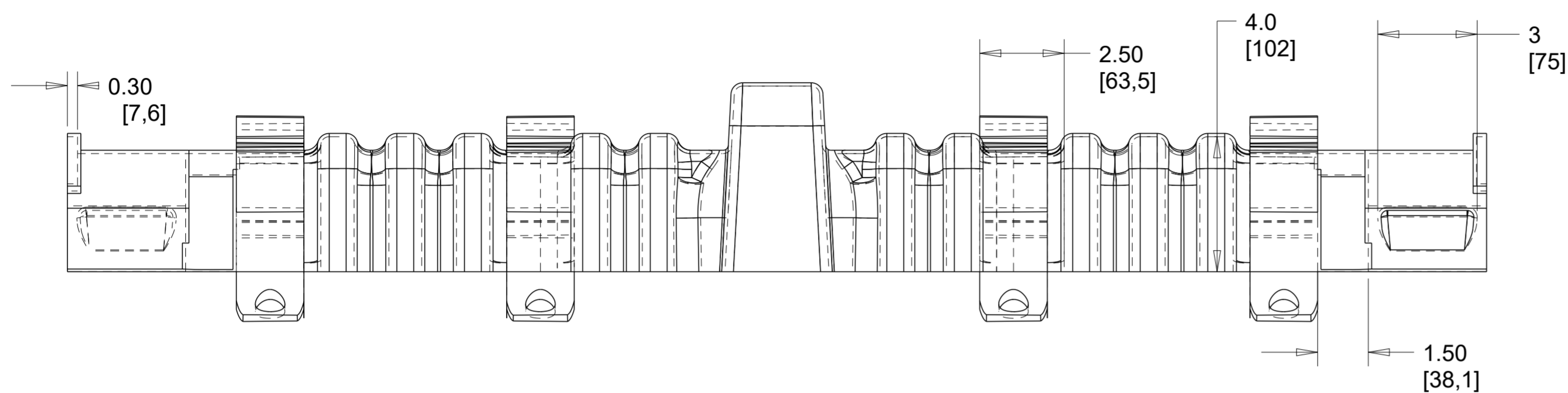

TCPN
CU6002-000

NOTES:

- 1. PARTS SHALL BE KITTED 6 PIECES PER BOX.
- 2. EACH BOX SHALL BE LABELLED WITH DESCRIPTION, LOT NUMBER, PART NUMBER, MANUFACTURING DATE AND QUANTITY

THIS DRAWING IS A CONTROLLED DOCUMENT.		DWN A. SABARAD 30MAY2020		
DIMENSIONS: INCH(MM)		CHK S. LIGHT 30MAY2020		
TOLERANCES UNLESS OTHERWISE SPECIFIED:		APVD L. HILLER 30MAY2020	NAME BCIC-G-PIN/CT-795-01(B6)	
0 PLC ±		PRODUCT SPEC	SIZE	
1 PLC ±0.1		APPLICATION SPEC	CAGE CODE	
2 PLC ±0.01			DRAWING NO	
3 PLC ±0.001		WEIGHT	RESTRICTED TO	
4 PLC ±0.0001			A2 00779	
ANGLES ±		CUSTOMER DRAWING	E00000845	
FINISH		SCALE	SHEET 1 OF 1	
		NTS	REV A	