

21-16 SKT ARRANGEMENT  
REFERENCE ONLY

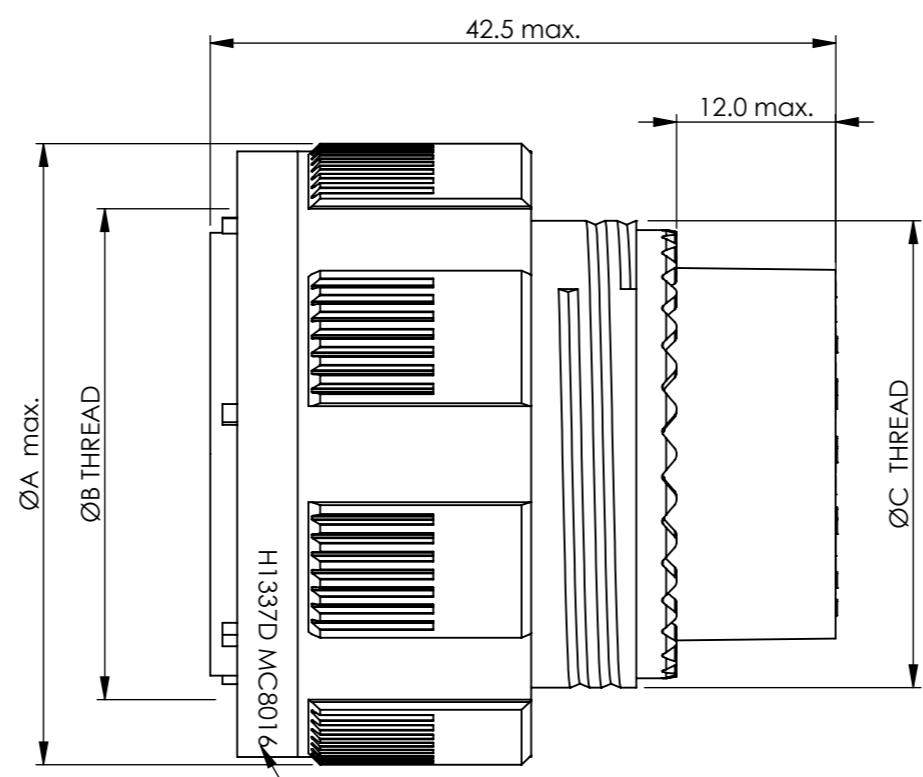

2 PRINT DETAIL  
(ON BLUE COLOUR BAND)

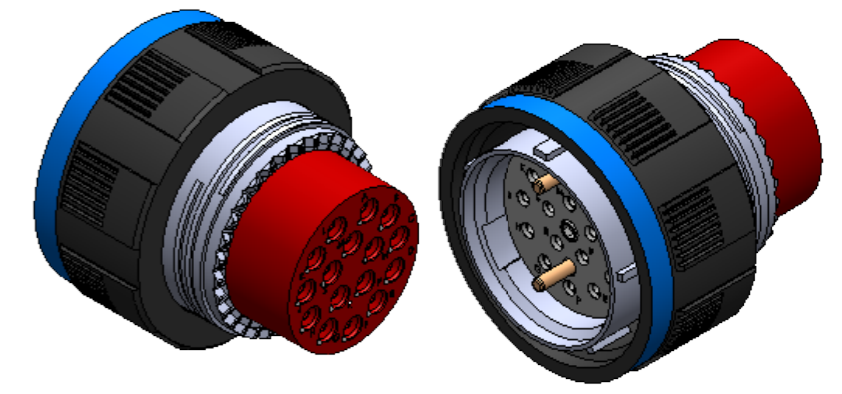

NOTES:

1. DUST CAPS TO BE FITTED TO CONNECTORS. CABLE ASSEMBLY TO BE PACKED IN A PROTECTIVE BAG MARKED WITH A MINIMUM OF THE PART NUMBER, BATCH NUMBER, DATE CODE AND ITEM DESCRIPTION.

2 MC801 PART NUMBER EXAMPLE: H\*\*\*\*D MC8016 -N -11-02 S N

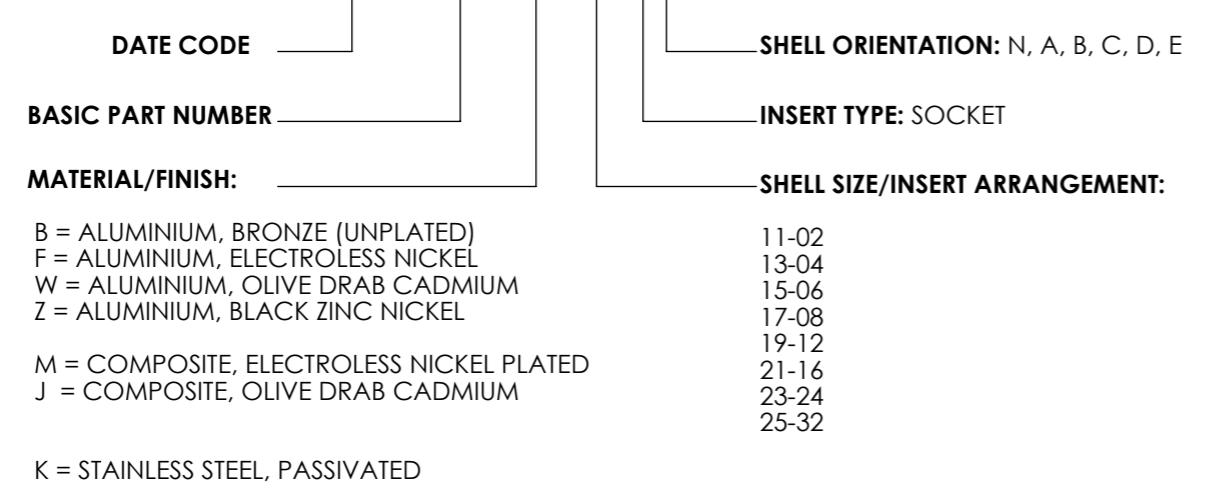

| SHELL SIZE | INSERT ARRANGEMENT | ØA MAX | B THREAD STUB 60° MOD 1P-3L CLASS 2A (IN INCHES) | ØC THREAD |
|------------|--------------------|--------|--|-----------|
| 11         | 2                  | 25.00  | 0.7500   | M15x1.0   |
| 13         | 4                  | 29.40  | 0.8750   | M18x1.0   |
| 15         | 6                  | 32.50  | 1.0000   | M22x1.0   |
| 17         | 8                  | 35.70  | 1.1875   | M25x1.0   |
| 19         | 12                 | 38.50  | 1.2500   | M28x1.0   |
| 21         | 16                 | 41.70  | 1.3750   | M31x1.0   |
| 23         | 24                 | 44.90  | 1.5000   | M34x1.0   |
| 25         | 32                 | 48.00  | 1.6250   | M37x1.0   |

|                        |                               |             |            |                            |  |
|------------------------|-------------------------------|-------------|------------|----------------------------|--|
| THIRD ANGLE PROJECTION | MATERIAL:                     |             | FINISH:    |                            | <p>DEUTSCH<br/>TE CONNECTIVITY UK LTD.,<br/>ST. LEONARDS-ON-SEA,<br/>TN38 9RF, UK.</p> |
|                        | TITLE: ARINC 801, TYPE 1 PLUG |             |            |                            |  |
| IF IN DOUBT, ASK       |                               | SIZE: A3    | SCALE: 1:1 | DRAWING NUMBER: 460069-ENV |  |
| ISSUE                  |                               | CHANGE NOTE |            | SHEET: 1 OF 1              | ISSUE: AE  |

|       |             |       |         |           |                |            |
|-------|-------------|-------|---------|-----------|----------------|------------|
| AE    | DUK-71225   | MJH   | NPO     | MJH       | NT             | 08/01/2020 |
| ISSUE | CHANGE NOTE | DRAWN | CHECKED | APP. ENG. | APP. MARKETING | DATE       |

THIS INFORMATION IS CONFIDENTIAL AND PROPRIETARY TO TYCO ELECTRONICS CORPORATION AND ITS WORLDWIDE SUBSIDIARIES AND AFFILIATES (TE). IT MAY NOT BE DISCLOSED TO ANYONE OTHER THAN TE PERSONNEL, WITHOUT AUTHORIZATION FROM TE (www.te.com).