

REVISIONS					
P	LTR	DESCRIPTION	DATE	DWN	APVD
	F	REVISED AS PER ECO-20-003569.	11MAR2020	TC	NP

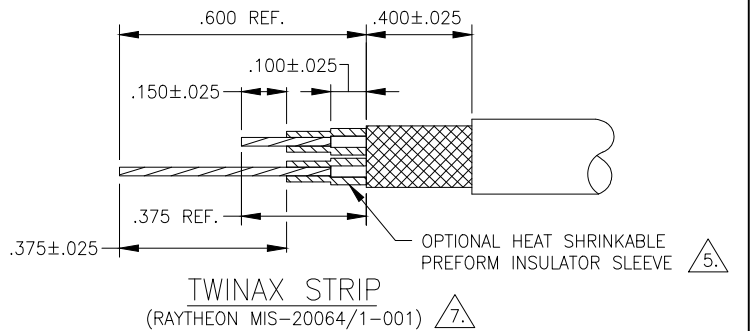
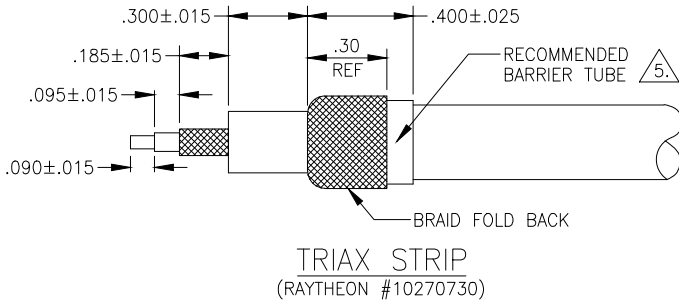
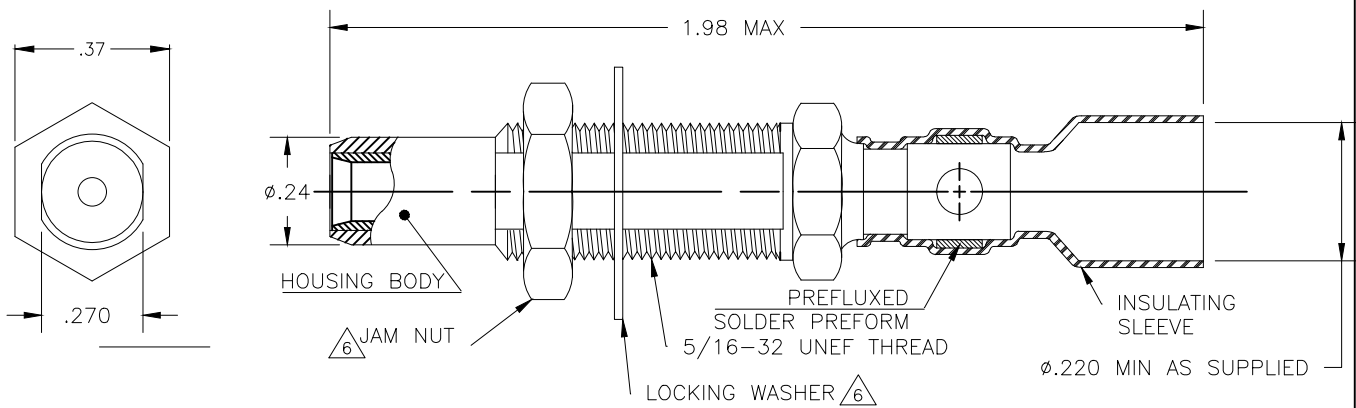

NOTES:

1. PART DESCRIPTION: CONNECTOR, JACK, TRIAXIAL, BULKHEAD (RAYTHEON # 1145047) COMPLETE WITH PREFLUXED SOLDER PREFORM RING AND HEAT SHRINKABLE INSULATING SLEEVE.

MATERIAL:

- HOUSING BODY: BRASS ALLOY PER ASTM B16 (QQ-B-626)
- JAM NUT: BRASS ALLOY PER ASTM B16 (QQ-B-626)
- INSULATING SLEEVE: HEAT SHRINKABLE, POLYVINYLIDENE FLUORIDE (TRANSPARENT BLUE)
- SOLDER RING: PREFLUXED SOLDER PREFORM, COMPOSITION Sn63, ROLO FLUX PER ANSI-J-STD-004.
- INSULATOR: THERMOPLASTIC PER LP 392.

FINISH:

- HOUSING BODY: TIN PLATED PER MIL-T-10727
- JAM NUT: NIQUEL PLATED PER QQ-N-290
- LOCK WASHER: PASSIVATED PER MIL-S-5002

- 2. HOUSING ACCOMMODATION: HOUSING DESIGNED TO ACCEPT SHIELDED CONTACTS MIS-20067/1 THRU MIS-20067/4 SHIELDED, RAYCHEM SOLDER TACT D-602-44/45 AND D-602-54/55.
- 3. WIRE SIZE: HOUSING WILL TERMINATE OUTER SHIELD OF TRIAX/ TWINAX CABLE HAVING A SHIELD DIA. OF .185 MAX.
- 4. MATING CONNECTORS: THIS CONNECTOR WILL MATE WITH D-621-0001 (RAYTHEON# 11453046) CONNECTOR, PLUG SUBMINIATURE, TRIAXIAL.

- 5. ITEMS SUPPLIED AS PART OF CONNECTOR ASSEMBLY.
- 6. JAM NUT AND LOCKING WASHER SUPPLIED UNASSEMBLED.
- 7. RECOMMENDED TWINAX STRIPPING TOOL AD-1479 OR AD-1496.
- 8. SEE PROCEDURE ES 61124 FOR TERMINATION INFORMATION.

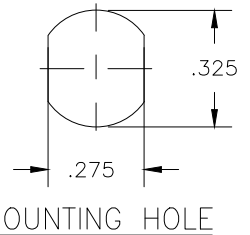

ACCESSORIES	
CTA-0012	BARRIER TUBE
CTA-0013	PREFORM INSULATOR SLEEVES (2)
D-600-0024	STRAIN RELIEF

TE Connectivity. All Rights Reserved. © 2020

DIMENSIONS: INCHES	DWN T.CORREIA 11MAR2020	MATERIAL	FINISH				
	CHK R.MACNAUGHTON 11MAR2020						
TOLERANCES UNLESS OTHERWISE SPECIFIED:	APVD N.PRZYBYLSKA 11MAR2020	TE Connectivity					
	PRODUCT SPEC						
0 PLC ± -		NAME CONNECTOR, JACK TRIAXIAL, BULKHEAD					
1 PLC ± -							
2 PLC ± 0.01		SIZE	CAGE CODE	DRAWING NO	RESTRICTED TO		
3 PLC ± 0.005		A4	06090	C-D-621-0002	-		
4 PLC ± -		WEIGHT		0.000000			
ANGLES ± -		CUSTOMER DRAWING					
		SCALE	DNS	SHEET	1 OF 1	REV	F