

THIS DRAWING AND THE INFORMATION SET FORTH HEREON ARE THE PROPERTY OF TYCO CORPORATION, AND ARE TO BE HELD IN TRUST AND CONFIDENCE. PUBLICATION, DUPLICATION, DISCLOSURE, OR USE FOR ANY PURPOSE NOT EXPRESSLY AUTHORIZED IN WRITING BY TYCO CORPORATION IS PROHIBITED.

REVISIONS

REV	DESCRIPTION	DATE	APPROVED
A	REVISED PER DCR NO. T-31842	6/11/03	GMR

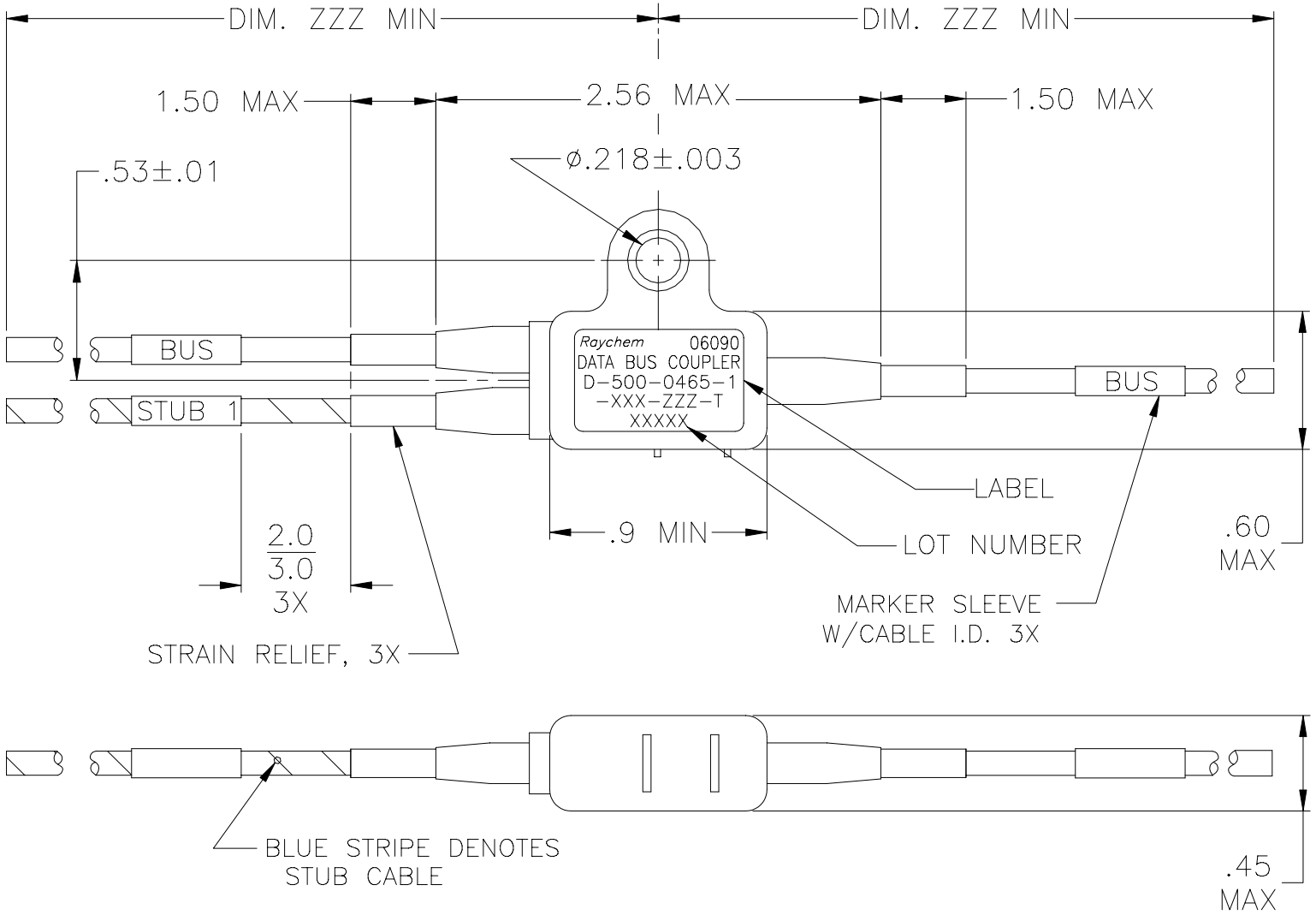

PART NO. D-500-0465-1-XXX-ZZZ-T
 1=SINGLE STUB TUBING, STRAIN RELIEF LENGTH OF CABLE IN INCHES
 CABLE
 612=10612 (SINGLE OPTIMIZED BRAID)
 613=10613 (DOUBLE OPTIMIZED BRAID)
 614=10614 (EMP HARDENED)

If this document is printed it becomes uncontrolled.
 Check for the latest revision.

SPECIFICATION CONTROL DRAWING

UNLESS OTHERWISE SPECIFIED DIMENSIONS ARE IN INCHES AND TOLERANCES ARE: .XXX ± .XX ± ANGLE ±	DRAWN T RATZLAFF	DATE 01JAN16	tyco Electronics	Tyco Electronics 300 CONSTITUTION DRIVE MENLO PARK, CALIFORNIA 94025 USA	Raychem	
	CHECKED	DATE				
	MATERIAL	APPROVED P DUTTON	DATE 01JAN16	TITLE DATABUS COUPLER SINGLE STUB IN-LINE W/CABLE STRAIN RELIEF AND MOUNTING LUG		
FINISH	CAD NAME T31842A	SIZE A	CODE IDENT. NO. 06090	DWG. NO. D-500-0465-1-XXX-ZZZ-T	SCALE: DO NOT SCALE THIS DRAWING	SHEET 1 OF 2



If this document is printed it becomes uncontrolled.
Check for the latest revision.

1. MATERIAL AND FINISHES:
 - 1.1 INTERNAL COMPONENTS:
 - 1.1.1 -TRANSFORMER TO MIL-PRF-21038 AND MIL-STD-1553B
 - 1.1.2 -RESISTORS TO MIL-PRF-39007/9, 57.6 OHMS
 - 1.2 SHIELDED CASE: ALUMINUM PER ASTM-B618
 - 1.3 SEALED STRAIN RELIEF COVER: MODIFIED CROSS-LINKED ELASTOMER, BLACK, TO RAYCHEM SPECIFICATION RK-6713.
 - 1.4 CABLE TYPE PER RAYCHEM SPECIFICATION 1200 (SEE PART NO. ON SHEET 1).
 - 1.5 STRAIN RELIEF TUBING: RAYCHEM TAT-125.
2. APPLICATION:
 - 2.1 THIS COUPLER IS DESIGNED TO BE INSTALLED AS A DIGITAL MULTIPLEX ASSEMBLY MEETING THE REQUIREMENTS OF MIL-STD-1553B.
 - 2.2 FOR CABLE SPLICING USE FLEXIBLE SPLICE KIT D-150-0708-5 (NOT SUPPLIED).
 - 2.3 CABLE BEND RADIUS PER SAE-AS50881 STATIC BEND: 5 x CABLE O.D. MIN.
DYNAMIC BEND: 10 x CABLE O.D. MIN.
3. TEMPERATURE:
 - 3.1 OPERATING TEMPERATURE: -65°C TO +150°C
4. PERFORMANCE SPECIFICATIONS:
 - 4.1 TRANSFORMER MEETS THE PERFORMANCE REQUIREMENTS OF MIL-STD-1553B.
 - 4.2 COUPLER MEETS THE PERFORMANCE REQUIREMENTS OF RAYCHEM SPECIFICATION D-6020.
5. WEIGHT:
 - 5.1 MAXIMUM WEIGHT WITHOUT CABLE: 17 GRAMS MAX.

SINGLE STUB COUPLER SCHEMATIC

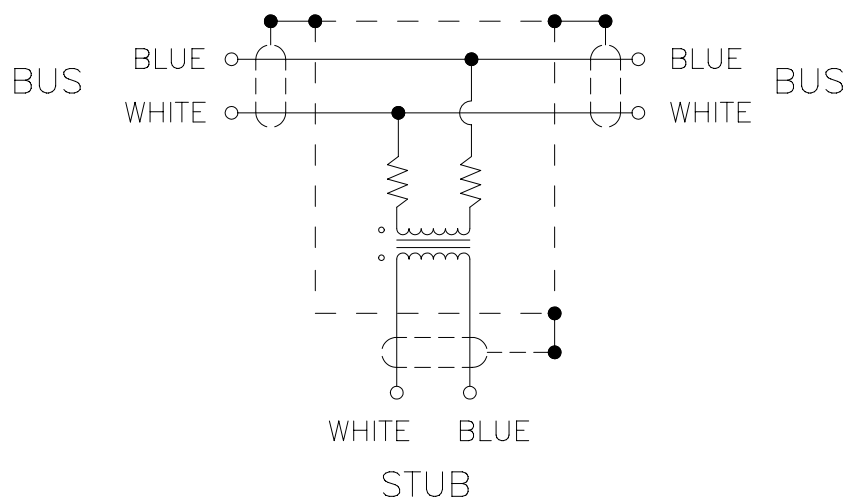

SPECIFICATION CONTROL DRAWING

DRAWN T RATZLAFF	DATE 16JAN2001	SIZE A	CODE IDENT. NO. 06090	DWG. NO. D-500-0465-1-XXX-ZZZ-T	REV A
CAD FILE T31842B	tyco Electronics	DO NOT SCALE THIS DRAWING			SHEET 2 OF 2