

REVISIONS			
LTR	DESCRIPTION	DATE	APPROVED
NC	REVISED PER ECN# T-20899	96JUL16	Z. TEMAN

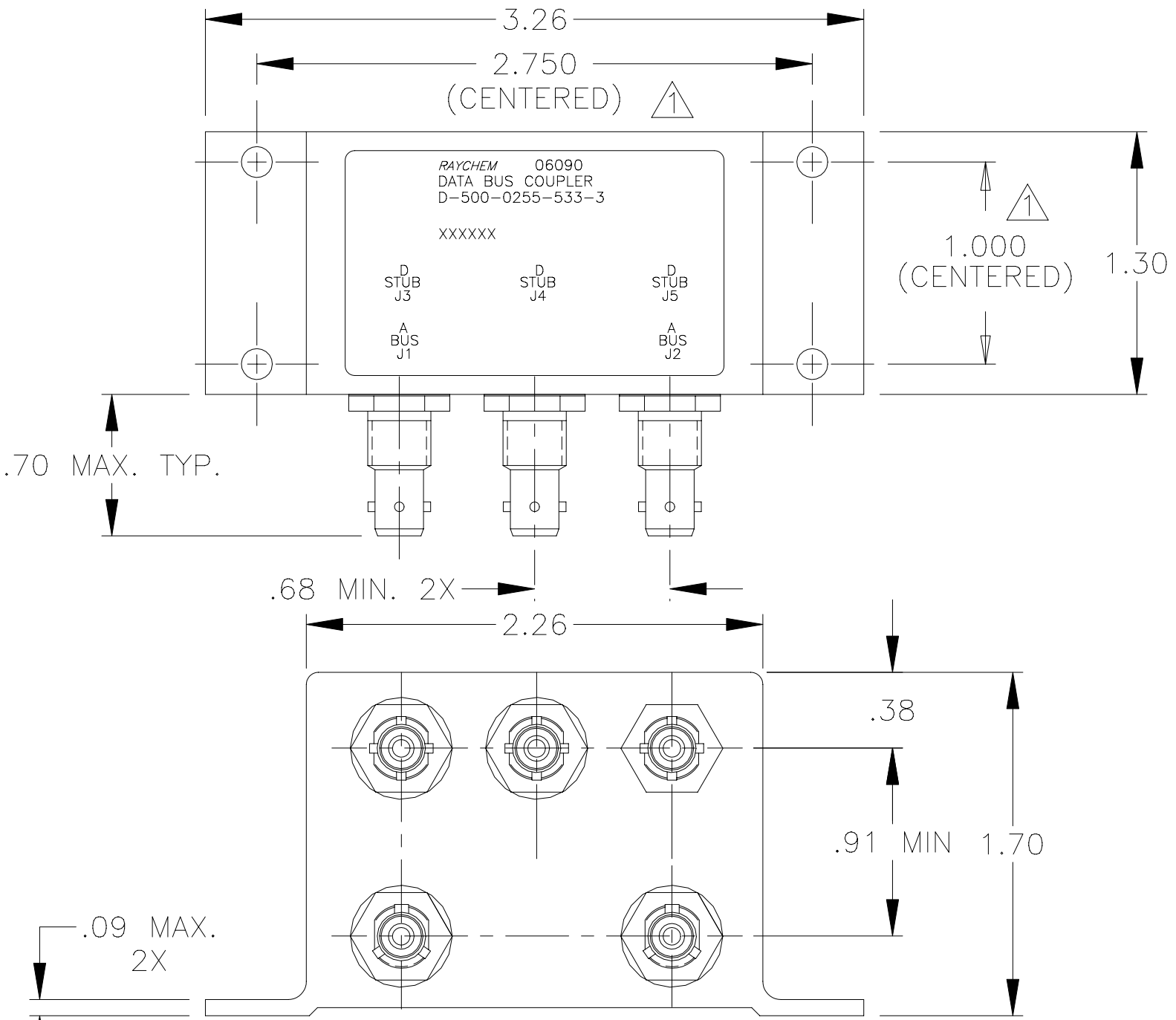

If this document is printed it becomes uncontrolled.
Check with the web for latest revision.

SPECIFICATION CONTROL DRAWING

UNLESS OTHERWISE SPECIFIED
DIMENSIONS ARE IN INCHES.
METRIC DIMENSIONS ARE
IN BRACKETS.

DECIMALS
.XXX ±.010 [— mm]
.XX ±.03 [— mm]

ANGLES
.X ± —

WEIGHT
146 GRAMS MAX.

DRAWN	Z.E.T.	96 JUL 16
CHECKED		
APPROVED		
APPROVED	Z.TEMAN	96 JUL 16
CAD NAME	004915-1.DWG	
THIRD ANGLE PROJECTION		



RAYCHEM CORPORATION
300 CONSTITUTION DRIVE
MENLO PARK, CALIFORNIA 94025

TITLE

3 STUB DATA BUS BAYONET COUPLER WITH TRIAXIAL CONNECTORS

SIZE	CODE IDENT. NO.	DWG. NO.	REV
A	06090	D-500-0255-533-3	NC

DO NOT SCALE THIS DRAWING

SHEET 1 OF 2

1.0 INTERMATEABILITY

CONNECTOR BOX JACK	MATING PLUG	KEY ("X")
DK-621-0434-1S	DK-621-0433-1P	A
DK-621-0440-4S	DK-621-0439-4P	D

2.0 PERFORMANCE

- 2.1 THIS COUPLER IS DESIGNED TO MEET THE APPLICABLE FUNCTIONAL REQUIREMENT OF RAYCHEM SPECIFICATION D-6021.
- 2.2 THE COUPLER SHALL OPERATE UNDER ANY OF THE ENVIRONMENTAL SERVICE CONDITIONS AS SPECIFIED IN MIL-E-5400, CLASS ∇ UPGRADED TO 125°C CONTINUOUS OPERATION.
- 2.3 ALTITUDE: SEA LEVEL TO 75,000 FEET

3.0

BUS JACKS J1 AND J2	STUB JACKS J3 THRU J5
DK-621-0434-1S "A"	DK-621-0440-4S "D"

SCHEMATIC DIAGRAM

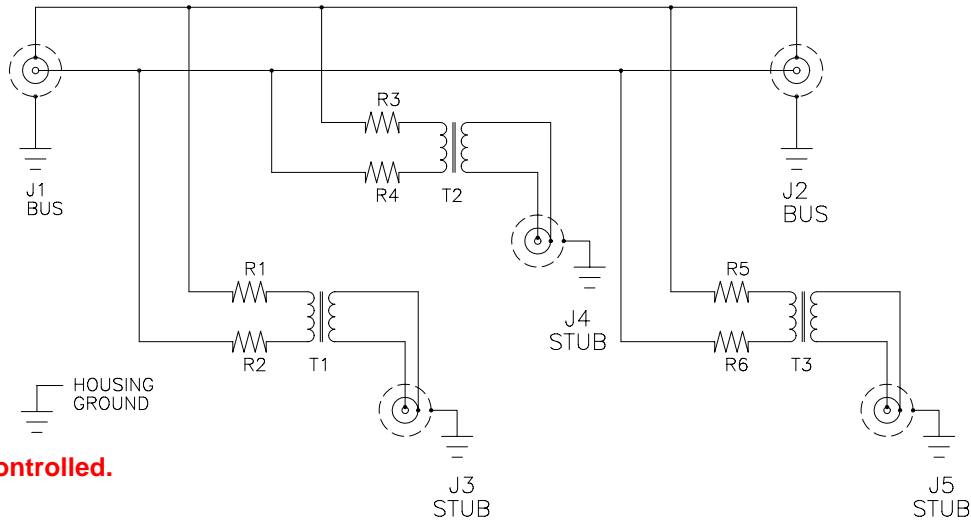

NOTES:

\triangle HOLE PATTERN MACHINED SYMMETRIC WITHIN MOUNTING FLANGE.

**If this document is printed it becomes uncontrolled.
Check with the web for latest revision.**

CAD NAME: 004915-2	DRAWN	Z.E.T.	96 JUL 16	SIZE	CODE IDENT. NO.	DWG. NO.	REV.
	ISSUED			A	06090	D-500-0255-533-3	NC
DO NOT SCALE THIS DRAWING						SHEET 2 OF 2	