

6

5

4

3

2

1

D

D

C

C

B

B

A

A

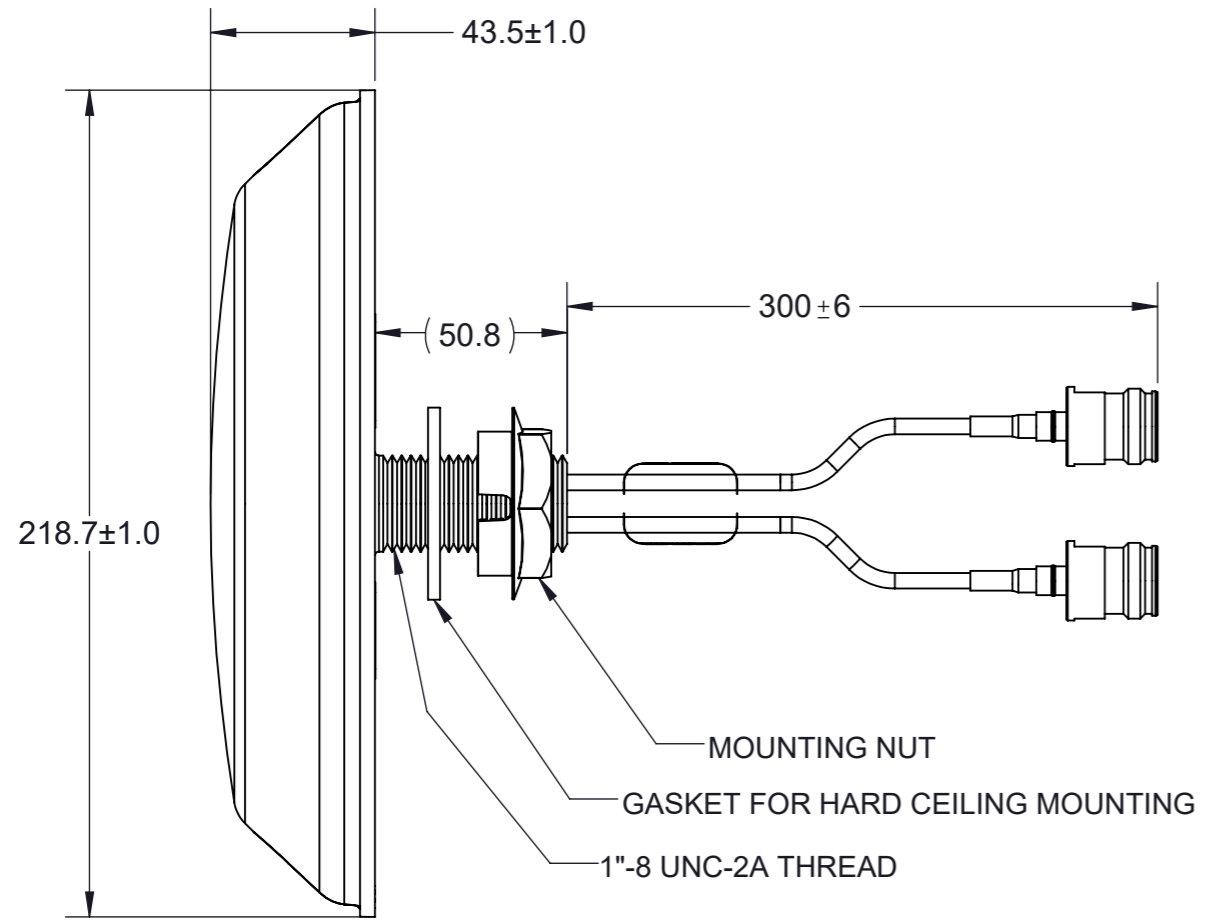

REVISIONS					
REV.	ECN#	ZONE	DESCRIPTION	CHANGED BY/DATE	APPROVED BY/DATE
1			PRELIMINARY COPY	YS TAN 09FEB18	WT NG 09FEB18
F01	ECO-18-00236		PRODUCTION RELEASED	YS TAN 08JUN18	WT NG 08JUN18
F02	ECO-18-00347		UPDATED SPECIFICATION TABLE	YS TAN 29AUG18	WT NG 29AUG18
F03	ECO-19-00205		UPDATED SPECIFICATION TABLE	YS TAN 15APR19	WT NG 15APR19
F04	ECO-20-00138		FREQ. BAND FROM "3300-4000" TO "3300-4200" MHz	YS TAN 17FEB20	WT NG 17FEB20

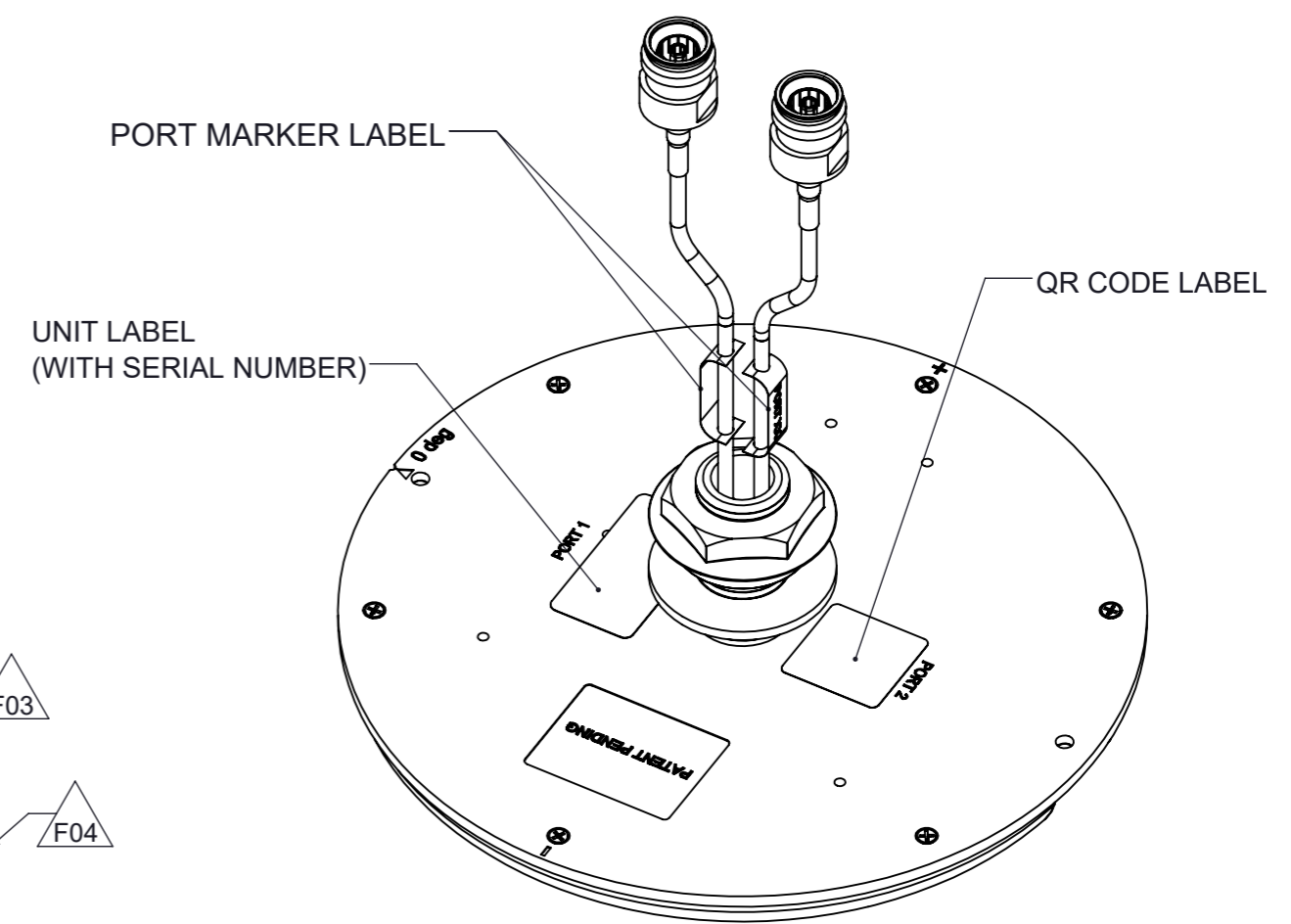

PARAMETER	SPECIFICATION									
Part No	CMD69423P-30D43F									
Ports	2									
Frequency Bands, MHz	698-806	824-894	880-960	1350-1550	1690-1880	1850-1990	1910-2180	2300-2500	2500-2700	3300-4200
Peak Gain, dBi (Max)	3.9	4.6	5.3	6.0	6.1	5.6	5.6	6.5	6.8	6.7
VSWR, Max	< 1.8:1			< 2.0:1			< 1.8:1			< 2.0:1
PIM, 3rd Order, 2x 20W (Max), dBc	< -150									
Isolation, dB (Min)	> 15		> 13		> 15			> 20		
Nominal Impedance, Ω	50									
Polarization	Linear - Vertical									
Azimuth Beam Width, °	360, Omnidirectional									
Max Power (Ambient 25°C/77°F), Watt	50									
Cable Length, cm/Connector	30/ 4.3-10, Female									
Antenna Dimension (Ht x Dia), mm	43.5 x 218.7									
Weight (Approximation), g	430									
Antenna Color	White									
Radome	PC+ABS, UL94-V0									
Operating Temperature, °C	-30 to +70									
Storage Temperature, °C	-40 to +85									
RoHS Compliance	YES									

F03

F04

MATERIAL: N/A		THIRD ANGLE PROJECTION	
FINISH:		DO NOT SCALE DRAWING	
APPROVALS		DATE	
DRAWN BY	YS TAN	09FEB18	
ELEC. ENG.	CC SU	09FEB18	
MECH. ENG.	YS TAN	09FEB18	
MFG./OPS.	HE KHOR	09FEB18	

INTERPRET DIMENSIONING AND TOLERANCING IN ACCORDANCE WITH ASME Y14.5M-2009

TOLERANCES UNLESS OTHERWISE SPECIFIED

DIMENSIONS ARE IN MILLIMETERS

ANGLE: ±30'
0 PLACE DECIMAL: ±0.5
1 PLACE DECIMAL: ±0.25
2 PLACE DECIMAL: ±0.13

SURFACE ROUGHNESS 1.6/√

Laird IAS, PENANG MALAYSIA

TITLE: **CMD69423P-30D43F MOUNTING & OUTLINE**

SIZE **A3** DWG. NO. **CMD69423P-30D43FMO** REV **F04**

SCALE: 1:2 PREVIOUS# SHEET 1 OF 1

UNLESS OTHERWISE NOTED, THIS DOCUMENT CONTAINS LAIRD CONFIDENTIAL INFORMATION. REPRODUCTION, USE, DISCLOSURE OR TRANSMITTAL OF ALL OR ANY PART OF THIS DOCUMENT IS PROHIBITED EXCEPT TO THE EXTENT APPROVED IN WRITING BY AN AUTHORIZED REPRESENTATIVE OF LAIRD. LAIRD RESERVES ALL RIGHTS UNDER PATENTS, TRADEMARKS, COPYRIGHTS AND TRADE SECRETS. COPYRIGHT, LAIRD 2017, ALL RIGHTS RESERVED.

6

5

4

3

2

1