

6

5

4

3

2

1

D

C

B

A

D

C

B

A

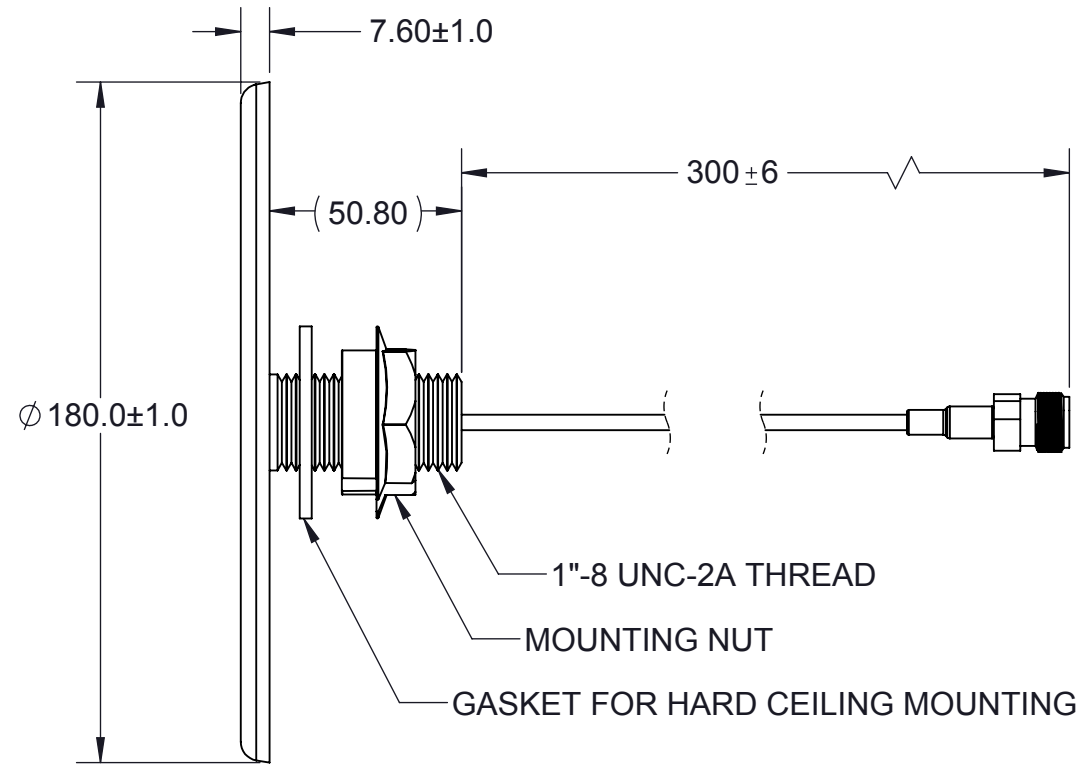

REVISIONS					
REV.	ECN#	ZONE	DESCRIPTION	CHANGED BY/DATE	APPROVED BY/DATE
F03	ECN-IAS-06018		REVISED SPECIFICATION TABLE	YS TAN 24FEB17	WT 24FEB17
F04	ECN-IAS-06101		FREQUENCY BAND 1910-2180 WAS 1910-2170	YS TAN 22MAR17	WT 22MAR17
F05	ECN-IAS-06128		ADD PIM SPEC FOR FREQUENCY BAND 2300-2700 MHz	YS TAN 05APRIL17	WTN 05APRIL17

PARAMETER	SPECIFICATION										
Part No	CFSA69383P-30NF										
Ports	1										
Frequency Bands, MHz	698-806	824-894	880-960	1350-1550	1690-1880	1850-1990	1910-2180	2300-2700	3300-3800	3800-4000	
Peak Gain, dBi (Max)	3.5	3.1	4.1	5.6	4.3	4.7	4.7	5.8	3.0	3.2	
VSWR, Max	< 1.5	< 1.5	< 1.5	< 2	< 1.5	< 1.5	< 1.5	< 1.5	< 1.8	< 2	
PIM, 3rd Order, 2 x 20W (Max), dBc	< -150										
Nominal Impedance, Ω	50										
Polarization	Linear - Horizontal										
Azimuth Beam Width, deg	360 , Omnidirectional										
Max Power (Ambient 25°C/77°F), Watts	50										
Cable Length/Connector, cm	30/ Type N, Female										
Antenna Dimension (Ht x Dia), mm	7.6 x 180										
Weight, g	214										
Antenna Color	White										
Radome	PC, UL94-V0										
Operating Temperature, °C	-30 to +70										
Storage Temperature, °C	-40 to +85										
RoHS Compliance	YES										

UNIT LABEL
(WITH SERIAL NUMBER)

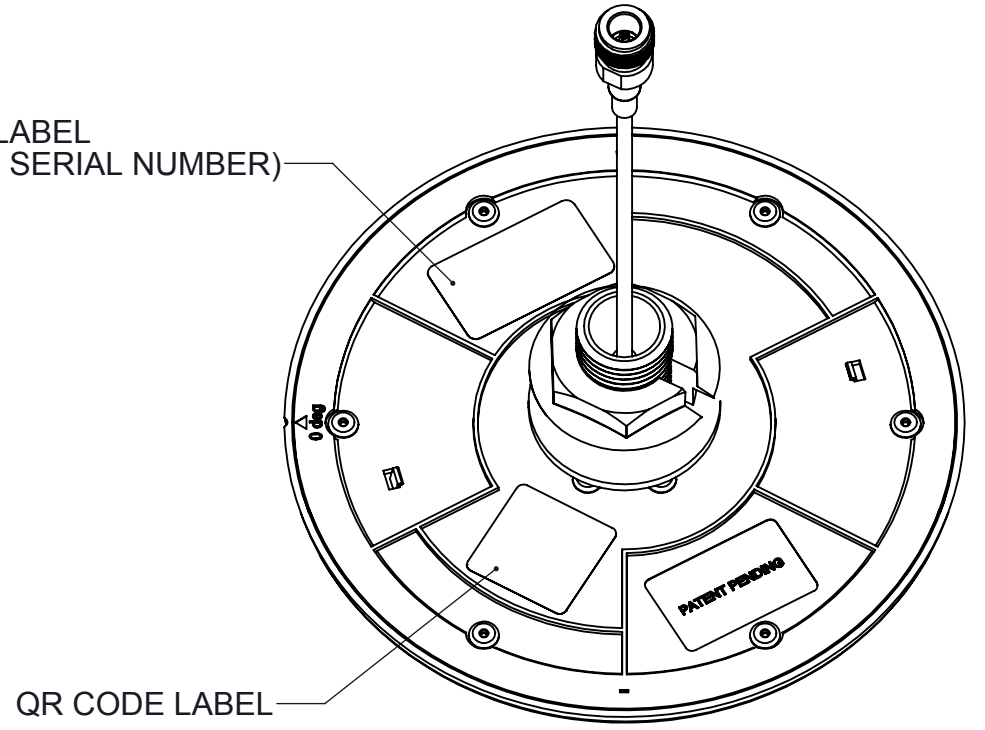

QR CODE LABEL

The component(s), including any plating, finishes, coatings, chemicals and surfaces treatments, supplied in this document/drawing must conform and comply with the latest issue of Laird Technologies Specification LT-GES-001, which fully includes but is not limited to all contents of EU Directives 2011/65/EC (RoHS Directive), as well as includes requirements of the Joint Industry Guide standard JIG-101, April 2005. The component(s) in this document/drawing may be subject to a full compound analysis for proof of compliance. The latest issue of Laird Technologies Specification LT-GES-001, (General Specification for the Environment) is readily available upon request from the supplier.

UNLESS OTHERWISE NOTED, THIS DOCUMENT CONTAINS LAIRD TECHNOLOGIES CONFIDENTIAL INFORMATION. REPRODUCTION, USE, DISCLOSURE OR TRANSMITTAL OF ALL OR ANY PART OF THIS DOCUMENT IS PROHIBITED EXCEPT TO THE EXTENT APPROVED IN WRITING BY AN AUTHORIZED REPRESENTATIVE OF LAIRD TECHNOLOGIES. LAIRD TECHNOLOGIES RESERVES ALL RIGHTS UNDER PATENTS, TRADEMARKS, COPYRIGHTS AND TRADE SECRETS. COPYRIGHT, LAIRD TECHNOLOGIES 2014. ALL RIGHTS RESERVED.

MATERIAL: N/A		THIRD ANGLE PROJECTION		IAS, PENANG MALAYSIA	
FINISH: N/A		DO NOT SCALE DRAWING			
APPROVALS		DATE		TITLE:	
DRAWN BY	YS TAN	06JAN17		CFSA69383P-30NF MOUNTING & OUTLINE	
ELEC. ENG.	KJ NG	06JAN17			
MECH. ENG.	YS TAN	06JAN17			
MFG./OPS.	ALEX KHOR	06JAN17			
INTERPRET DIMENSIONING AND TOLERANCING IN ACCORDANCE WITH ASME Y14.5M-2009		DIMENSIONS ARE IN MILLIMETERS		SIZE	
TOLERANCES UNLESS OTHERWISE SPECIFIED		ANGLE: ±30'		DWG. NO.	
0 PLACE DECIMAL: ±0.5		1 PLACE DECIMAL: ±0.25		A3 CFSA69383P-30NFMO	
1 PLACE DECIMAL: ±0.25		2 PLACE DECIMAL: ±0.13			
2 PLACE DECIMAL: ±0.13		SURFACE ROUGHNESS 1.6/√		F05	
SCALE: 1:2		PREVIOUS#		SHEET 1 OF 1	