

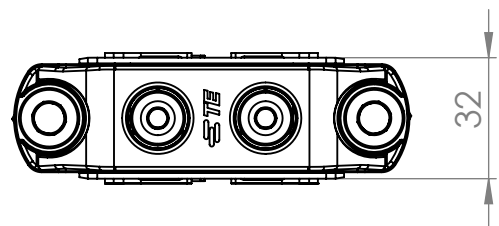

ratio 1 : 1.5

POS-NO.	DESCRIPTION	QTY
1	Half frame, Al alloy	2
2	Insulation housing, PBT	2
3	Teeth element, brass tin-plated	4
4	Nut in frame half, steel	2
5	Washer, steel	2
6	Screw for frame half with inside hexagon head SW8, steel	2
7	Screw for tap connection SW5, steel	4
8	Side wedges black, PBT	2
9	Spacer rectangular, PBT	1
10	Spacer for neutral teeth element	1

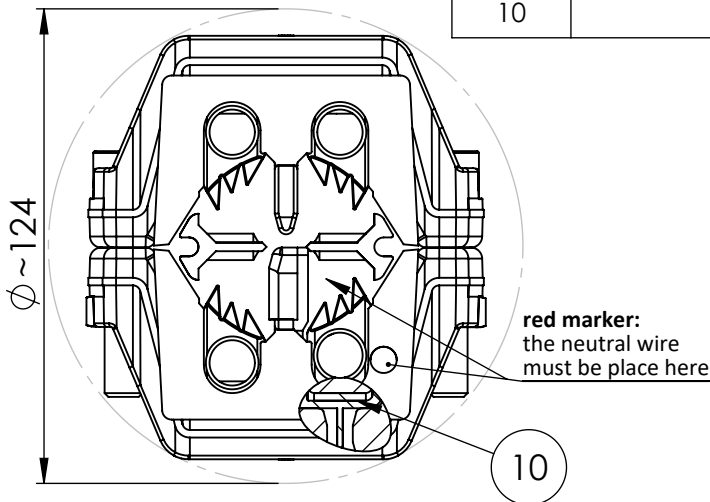

BURR PROJECTION:		DEBUR AND BREAK SHARP EDGES		DO NOT SCALE DRAWING		REVISION: 1	
FORM BOUND MEASURE:		DIMENSION: mm		This Information is confidential and proprietary to Tyco Electronics Corporation and it's subsidiaries and affiliates. It may not be disclosed to anyone, other than Tyco Electronics personnel, without written authorization from Tyco Electronics Corporation, Harrisburg, Pennsylvania USA.			
NOT FORM BOUND MEASURE:				DESCRIPTION: HEL-6880.3-RE, RPN: A26616-000 CABLE RING CONNECTOR FOR 3.5 cable MAIN: 3x240sm+1x120re BRANCH: 6-50			
NAME	SIGNATURE	DATE	DWG NO.		C-HEL-6880.3-RE		A4
DRAWN S. Pollakowski		10.09.2021	SCALE:		1:2	SHEET: 1 OF 1	
CHK'D			WEIGHT:		0,694kg		
APPV'D							
 Tyco Electronics Raychem GmbH a TE Connectivity Ltd. company Trachenberggring 85 12249 Berlin (Germany)							