

REVISIONS			
REV	DESCRIPTION	DATE	APPV
A	PRODUCTION RELEASE	AJVM 11/2/22	

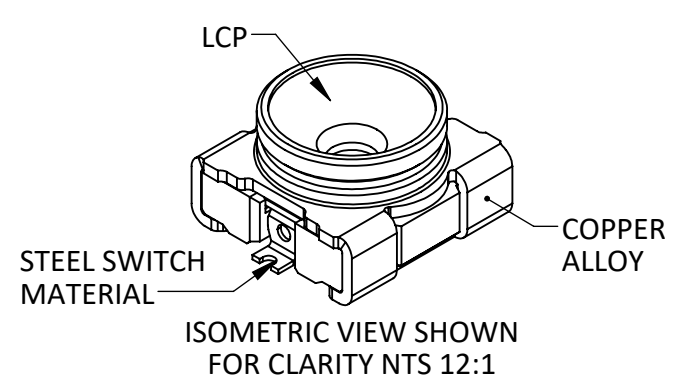

- ALL DIMENSIONS ARE IN MILLIMETERS [IN].
- DIMENSIONS APPLY AFTER FINISHING.
- MANUFACTURE TO BE COMPLIANT WITH EU RoHS DIRECTIVE, USE MATERIALS THAT DO NOT CONTAIN REACH SUBSTANCES OF VERY HIGH CONCERN >1000ppm, AND USE DRC CONFLICT-FREE SOURCED MATERIALS.
- ELECTRICAL PROPERTIES ARE SHOWN FOR REFERENCE ONLY. SEE DATA SHEET FOR COMPLETE LIST OF SPECIFICATIONS.
 - FREQUENCY: DC-11GHz
 - INSERTION LOSS: NTE 0.6dB
 - IMPEDENCE: 50Ω
 - POWER RATING: 2W
- PRODUCT TESTED IAW INTERNAL TEST PLAN AT LATEST REVISION.
- UNLISTED DIMENSIONS ARE CONTROLLED BY SOLID MODEL AT LATEST REVISION.
- MECHANICAL:
 - OPERATING TEMPERATURE: -40°C TO +85°C
 - STORAGE TEMPERATURE: -10°C TO +40°C
 - DURABILITY: 500 CYCLES
 - SHOCK: 75G MAX
 - REFLOW CAPABLE. SEE DATA SHEET FOR HEATING PROFILE
 - ENVIRONMENTALLY TESTED IAW EIA 364
- PACKAGE PER PURCHASE ORDER AND LABEL LOT BAGS IAW LABEL DRAWING PROVIDED.

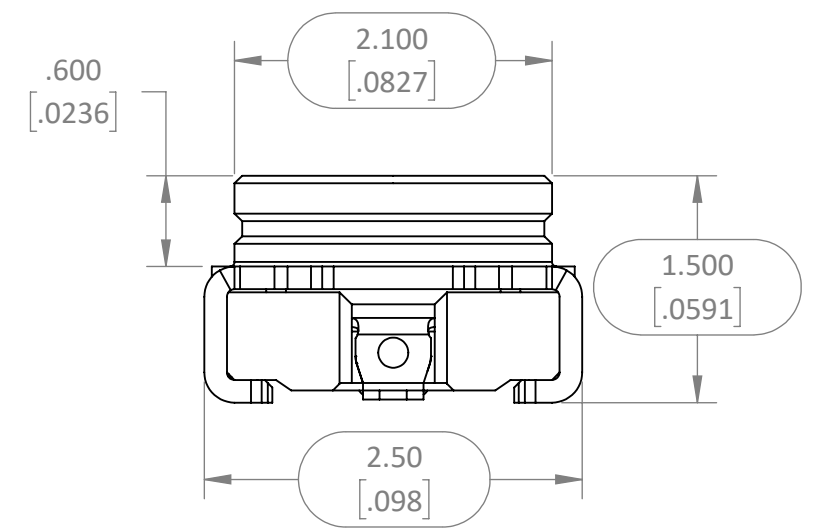
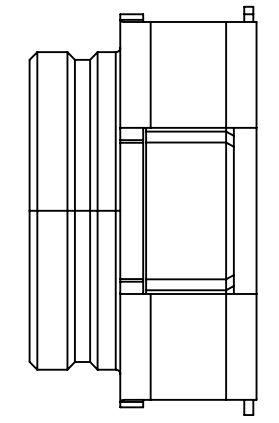
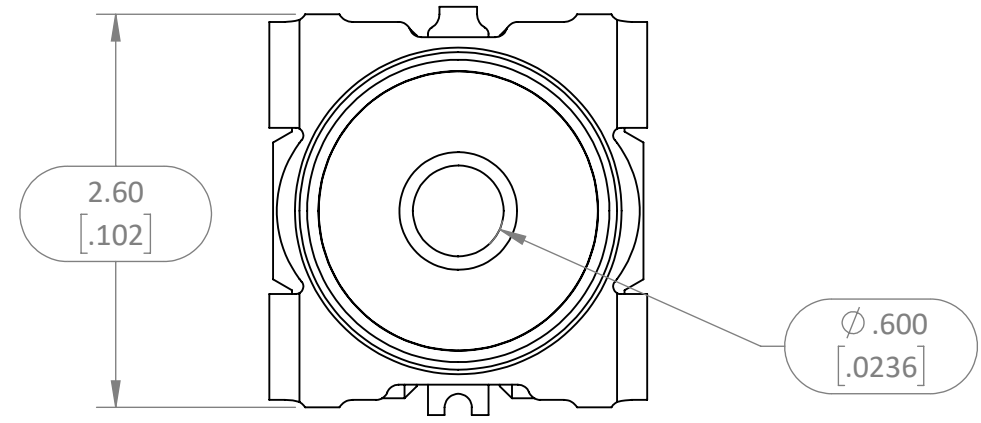
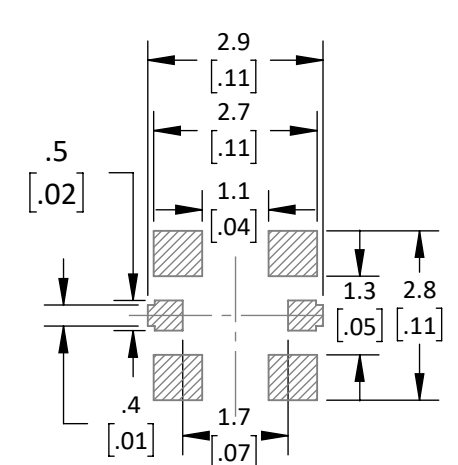
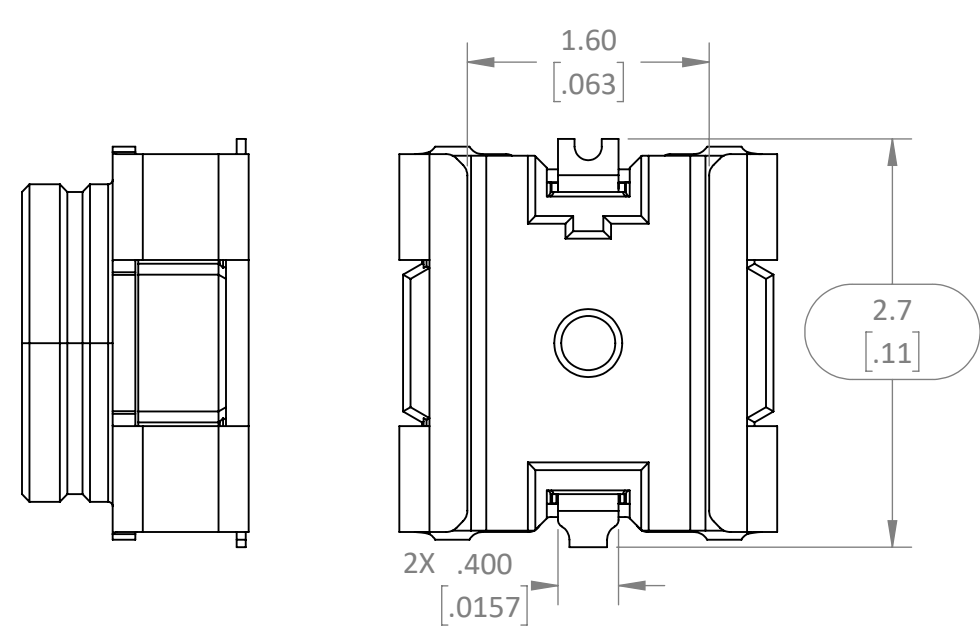

RECOMMENDED PCB LAYOUT
DIMENSIONING TYPICAL FOR LIKE FEATURES
GENERAL LAYOUT TOLERANCE: ±.05mm

WARNING: THIS DRAWING CONTAINS PROPRIETARY INFORMATION THAT IS THE SOLE PROPERTY OF LINX TECHNOLOGIES, AND SHALL BE TREATED AS SUCH. NO DISCLOSURE OR REPRODUCTION OF THIS DOCUMENT IS PERMITTED, IN WHOLE OR IN PART, WITHOUT THE EXPRESS WRITTEN PERMISSION OF LINX TECHNOLOGIES OR ITS DESIGNATED AGENTS.

STE 159 ORT LANE
connectivity MERLIN, OR 97532

MATERIAL: LCP COPPER ALLOY STEEL	INTERPRET DIMENSIONS AND TOLERANCES PER ASME Y14.5. .X ±2.0 .XX ±1.00 .XXX ±.500	ANGLES: ±1° SURFACE: √	PROJECTION:
FINISH: BLACK GOLD	DRAWN: AJVM ENGR: DASARATHAN	DT: 11/2/2022 DT: 11/3/2022	

TITLE: CONNECTOR SWITCH MINI RF2 SURFACE MOUNT		
SIZE B	DWG. NO. CONSWF001-SMD	REV A
SCALE: 20:1	DO NOT SCALE DRAWING	SHEET 1 OF 1