

REVISIONS				
REV	DESCRIPTION	DATE	DWN	APVD
A	CUSTOMER DRAWING DRAWING RELEASE	10/13/2023	JH	CM

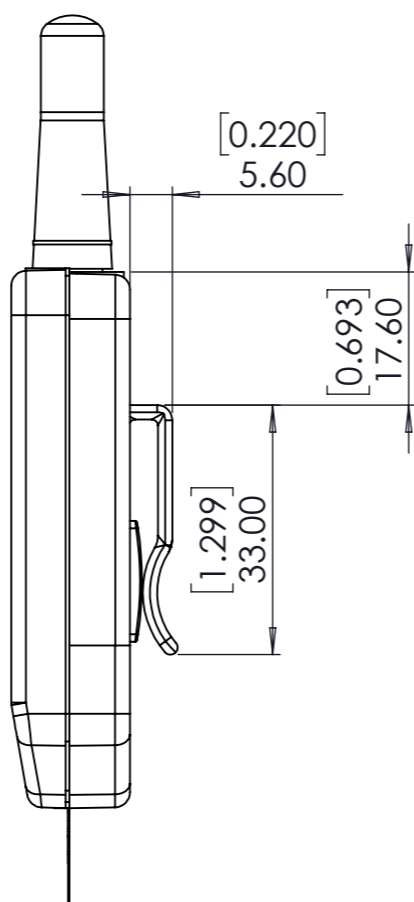
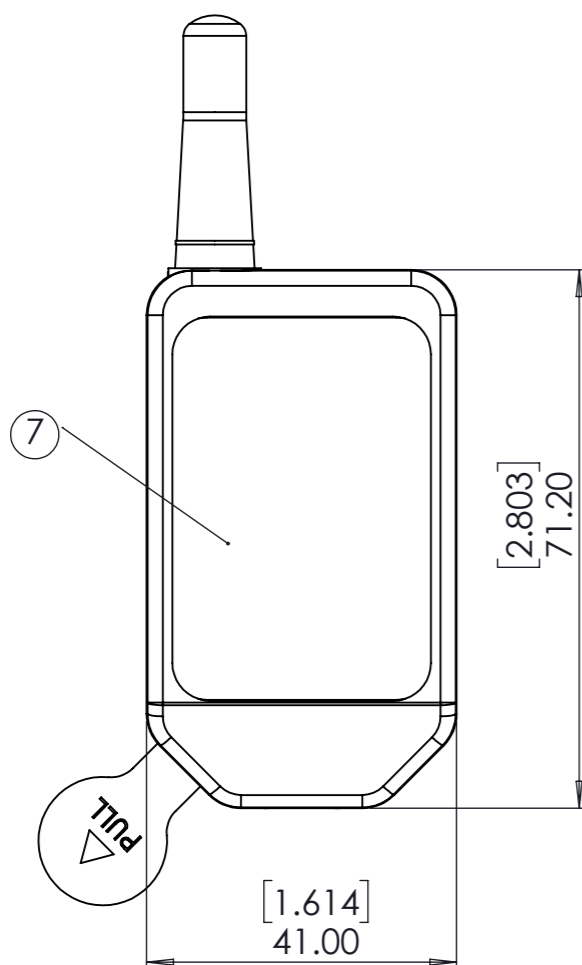
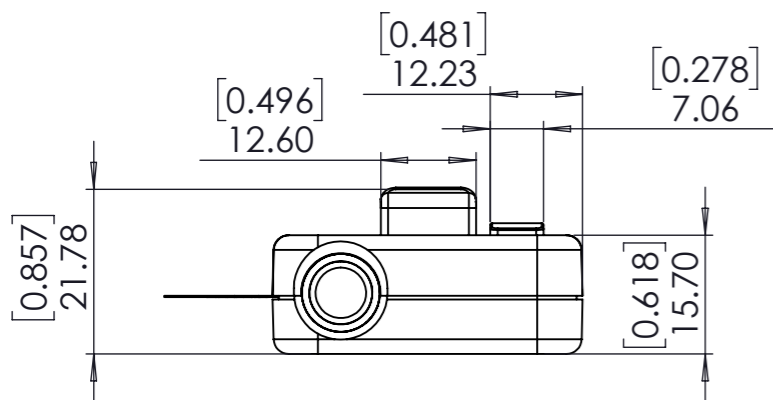

- MANUFACTURE TO BE COMPLIANT WITH EU RoHS DIRECTIVE, USE MATERIALS THAT DO NOT CONTAIN REACH SUBSTANCES OF VERY HIGH CONCERN 1000ppm, AND USE DRC CONFLICT-FREE SOURCED MATERIALS.
- ELECTRICAL SPECIFICATIONS** ARE SHOWN FOR REFERENCE ONLY. FOR OPERATING, PAIRING AND USAGE INSTRUCTIONS PLEASE SEE TE DATA SHEET AT LATEST REVISION
  - FREQUENCY: SEE TABLE
  - ELECTRONIC ASSEMBLY IAW IPC-A-610
  - FREQUENCY DESIGNATION REPRESENTED BY "FFF".
- ENVIRONMENT:**
  - USAGE TEMPERATURE: -40 TO 85°C
  - LR DESIGNATION IS IN REFERENCE TO THE CAPACITY FOR LONGER RANGE TRANSMISSION BASED ON THE STANDARD CP COUNTERPART WITH THE ADDITION OF AN ANTENNA. SEE DATA SHEET FOR MORE DETAILS.
- USAGE APPLICATION NOTES:**
  - TORQUE SCREW TO 4.0 IN-LB [0.45 N-m]. AVOID OVERTIGHTENING OF SCREW AND CAUSING DEFORMATION AT THE SIDE OF THE ENCLOSURE.
  - REMOVE BATTERY TAB BEFORE USE
  - REPLACE BATTERY WITH CR2032 COIN CELL WHEN APPLICABLE. SEE DATA SHEET FOR METHOD
  - AVOID LEAVING UNIT IN PLACES OF HIGH SOLAR LOADING TO PREVENT DAMAGE.
  - AVOID PLACES OF HIGH CHEMICAL CONTENT SUCH AS CHLORINE OR FUEL/HYDRAULIC VAPOR.
  - UNIT SHOULD NOT EXPERIENCE SIGNIFICANT SHOCK FROM DROPPING TO HARD SURFACES. USE BUMPER AND LANYARD KIT [OTX-ACC-KIT-HH-XX] IF THE APPLICATION REQUIRES THIS ACCESSORY.
  - THIS IS A GENERALLY MADE TO ORDER OEM PRODUCT. SEE YOUR SALES REPRESENTATIVE FOR DETAILS SUCH AS AVAILABLE COLORS AND BUTTON LAYOUTS FOR YOUR APPLICATION.
- PACKAGING NOTES:**
  - WRAP UNITS IN BUBBLE SLEEVE TO PROTECT FINISH.
  - PACK FLAT 10/ LOT BAG
  - PLACE IN CONTAINER OF 150 UNITS

THIS DRAWING IS A CONTROLLED DOCUMENT.

DWN	10/13/23
JHAGER	
CHK	10/13/23
CLEWIS	
APVD	10/13/23
CMURPHY	
PRODUCT SPEC	
APPLICATION SPEC	
WEIGHT	g
CUSTOMER DRAWING	



NAME  
HANDHELD REMOTE DS TRANSMITTER  
[FFF]MHZ 8BTN HHLR TX FCC CERT

SIZE	CAGE CODE	DRAWING NO	RESTRICTED TO
A3	00779	©=CMD-HHLR-FFF-MD	-
SCALE 1:1		SHEET 1 OF 2	REV A

TABULATION MATRIX

TCPN	DESCRIPTION
CMD-HHLR-315-MD	REMOTE DS 315MHZ OOK AM 8BTN HHLR TX FCC
CMD-HHLR-418-MD	REMOTE DS 418MHZ OOK AM 8BTN HHLR TX FCC
CMD-HHLR-433-MD	REMOTE DS 433MHZ OOK AM 8BTN HHLR TX FCC

DIMENSIONS: mm	TOLERANCES UNLESS OTHERWISE SPECIFIED:
	0 PLC ± 0.5
	1 PLC ± 0.25
	2 PLC ± 0.13
	3 PLC ±
	4 PLC ±
	ANGLES ± 30'

MATERIAL	FINISH
VAR ABS	

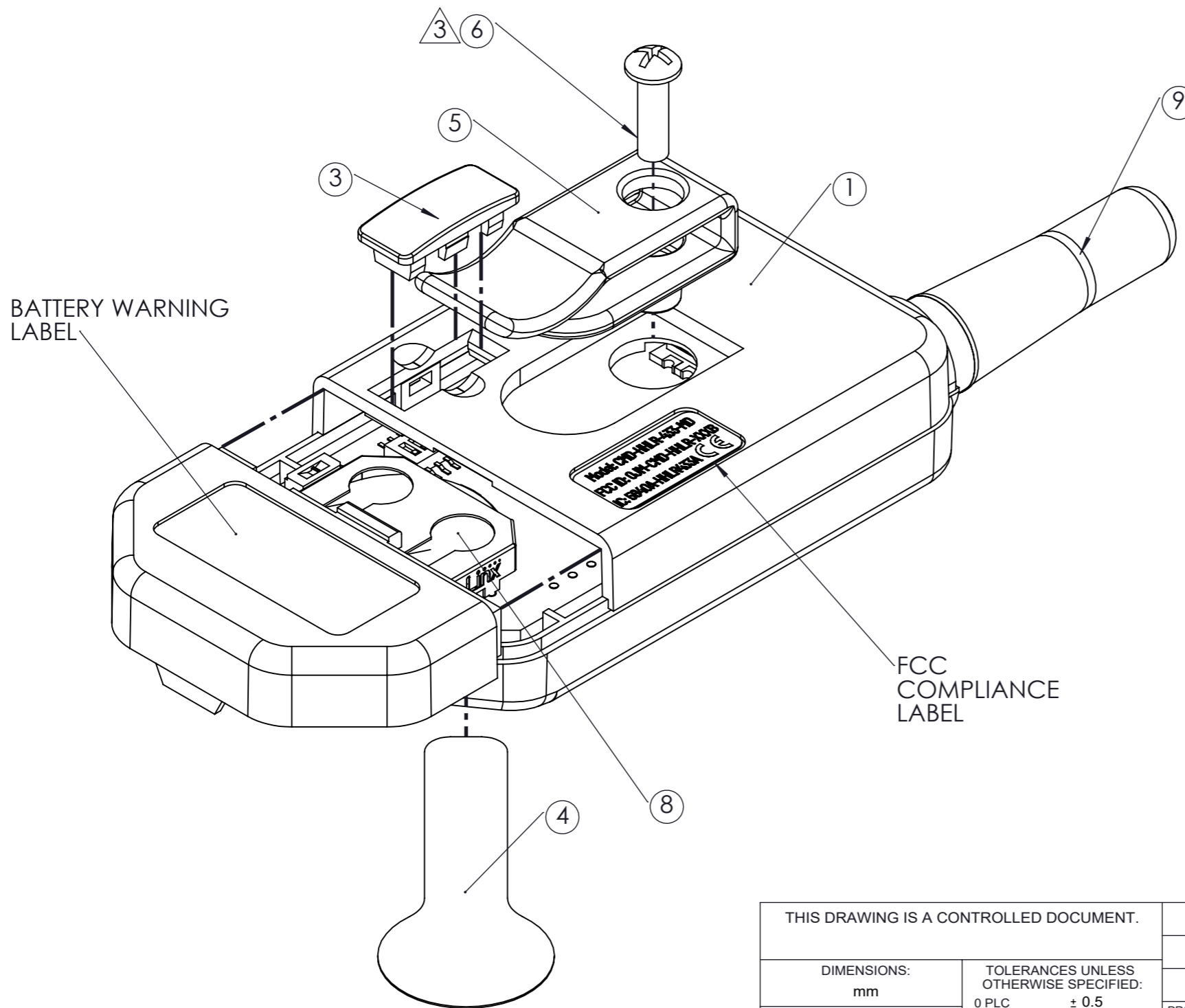

LIST OF ITEMS AND MATERIALS	
ITEM	DESCRIPTION
1	CMD HANDHELD LONG RANGE BODY
2	CMD HANDHELD UNIT BATTERY COVER
3	CMD HANDHELD UNIT PROGRAMMING COVER
4	BATTERY PROTECTION TAB (DISPOSABLE)
5	CLIP BELT SCR MOUNT ABS PLAS
6	SCREW PPH M3X10 STEEL ZINC
7	SWITCH MEMBRANE CUSTOM MP467 BACK
8	BATT LITHIUM 1.2V COIN 2032
9	ANTENNA LONG RANGE

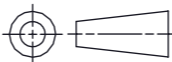
THIS DRAWING IS A CONTROLLED DOCUMENT.		<b>TE</b> TE Connectivity	
DIMENSIONS: mm 		NAME HANDHELD REMOTE DS TRANSMITTER [FFF]MHZ 8BTN HHLR TX FCC CERT	
TOLERANCES UNLESS OTHERWISE SPECIFIED: 0 PLC ± 0.5 1 PLC ± 0.25 2 PLC ± 0.13 3 PLC ± 4 PLC ± ANGLES ± 30°		PRODUCT SPEC - APPLICATION SPEC - WEIGHT g	RESTRICTED TO - SIZE <b>A3</b> CAGE CODE <b>00779</b> DRAWING NO <b>©-CMD-HHLR-FFF-MD</b>
MATERIAL	FINISH	CUSTOMER DRAWING SCALE 2:1 SHEET 2 OF 2 REV A	