

DRAWING NO: NAA1400-1490-C
THIS DRAWING IS A CONTROLLED DOCUMENT



ARMOUR RODS

CATALOGUE NUMBER: NAA1400-1490 SUITS CONDUCTOR

STRANDING	COND. TYPE	DIAMETER	FITTING LAY
7/4.75	AAC/AAAC	14.25	RIGHT HAND
6/4.75 + 7/1.60	ACSR	14.30	RIGHT HAND
6/0.186 + 7/0.062	ASCR	14.17	RIGHT HAND

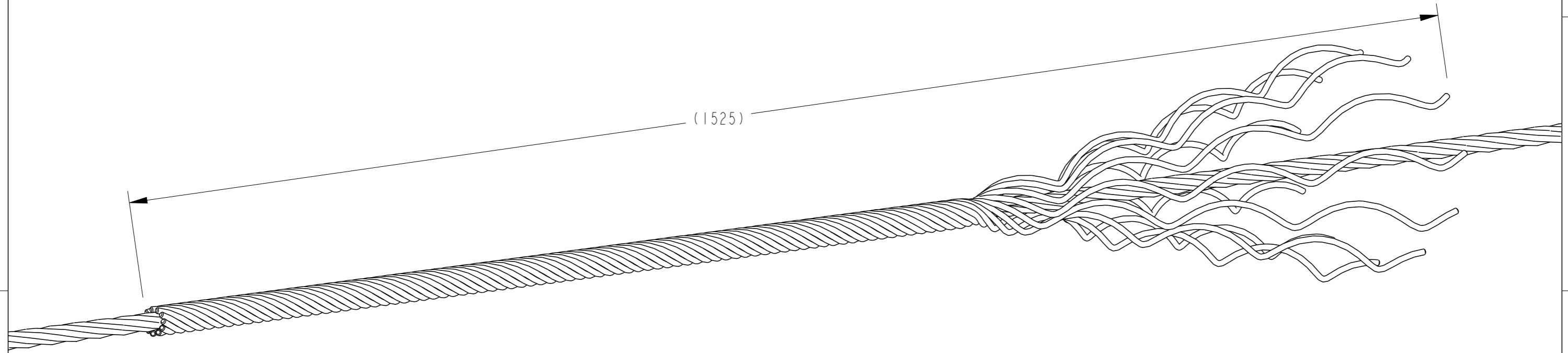

TECHNICAL SPECIFICATIONS:

CATALOGUE NUMBER: NAA1400-1490
DESCRIPTION: NON-TENSION ALUMINIUM ARMOUR RODS (NAA) FITTING
MATERIAL: ALUMINIUM ALLOY
NUMBER OF RODS: 11
ROD DIAMETER: 4.47mm
OVERAL LENGTH: 1525mm
END FINISH: BALLENDDED
FITTING LAY DIRECTION: RIGHT HAND
COLOUR CODED: BLUE
RODS ARE LABELED, BUNDLED IN A SET AND TAPED AT BOTH ENDS.

BOX LABEL

P/N: NAA1400-1490
ID:
DESCRIPTION:
 NON-TENSION ALUMINIUM ARMOUR RODS (NAA) FITTING
 7/4.75 AAC/AAAC
 6/4.75 + 7/1.60 ACSR
 6/0.186 + 7/0.062 ASCR
RANGE: 14.00 - 14.90
COLOUR-CODE: BLUE
QTY: 20 **WEIGHT:** **BATCH:**

PRODUCT LABEL

NAA1400-1490
 7/4.75 AAC/AAAC
 6/4.75 + 7/1.60 ACSR
 6/0.186 + 7/0.062 ASCR

WEIGHT: 0.75kg
BATCH NO:
MONTH/YEAR:

THIS INFORMATION IS CONFIDENTIAL AND PROPRIETARY TO TE CONNECTIVITY CORPORATION AND ITS WORLDWIDE SUBSIDIARIES AND AFFILIATES. IT MAY NOT BE DISCLOSED TO ANYONE, OTHER THAN TE CONNECTIVITY PERSONNEL, WITHOUT WRITTEN AUTHORIZATION FROM TE CONNECTIVITY CORPORATION, AUSTRALIA.

LOC								IMPLIED NOTES BURRS AND SHARP EDGES REMOVED SCREW THREADS ARE TO AS 1275 DO NOT WORK TO DIMS MARKED REF SURFACE FINISH 6.3 U.N.O. DIMS ARE IN mm. DO NOT SCALE	IMPLIED TOLERANCES HOLE DIA AND LOCATIONS: ±0.5mm. DIMENSIONS UP TO 30mm: ±1.5mm. DIMENSIONS OVER 30mm: ±5%. UP TO A MAX OF: ±5mm. ANGULAR DIMENSIONS: ±5°	TCPN - PART Alias UTX/DUL NAA1400-1490 Cat No NAA1400-1490	TITLE NON-TENSION ALUMINIUM ARMOUR RODS (NAA) FITTING COND. RANGE: Ø14.00-Ø14.90 7/4.75 AAC/AAAC 6/4.75 + 7/1.60 ACSR 6/0.186 + 7/0.062 ASCR	DRAWN RN CHECKED MN	DATE 29-04-2013 APPROVED AT	TE Connectivity 2/3 Corella Close Berkeley Vale NSW 2261 Australia			
DIST	—	I	NEW RELEASE	29-04-2013	RN	AT	MATERIAL DESC ALUMINIUM ALLOY	MATERIAL NO -	MATL SPEC/STD/DRG NO -	PROCESS SPEC HEAT TREAT/PLATING NO -	SIZE A3	PROJECTION 3RD ANGLE	SCALE NTS	DRAWING NO NAA1400-1490-C	SHEET 1	OF 1	REV 1
POS	REV	REVISION RECORD			DATE	DWN	APVD				Format: generic_m03.au.r1.frm	4	Template: tec_generic_a3.metric.au.r1.drw	3	Dwg No from P1 Mod Fam Tbl: 2	>AUXXXXX	1

D
C
B
A