

4

3

2

1

THIS DRAWING IS UNPUBLISHED. VERTRAULICHE UNVERÖFFENTLICHTE ZEICHNUNG  
 RELEASED FOR PUBLICATION FREI FUER VERÖFFENTLICHUNG  
 © COPYRIGHT 19- BY AMP INCORPORATED. ALL RIGHTS RESERVED. ALLE RECHTE VORBEHALTEN

MATED WITH: PASSEND ZU:	LOC AI	DIST -	REVISIONS ÄNDERUNGEN					
			P	LTR	DESCRIPTION BESCHREIBUNG	DATE	DWN	APVD
	PROJEKT NR.:			A2	REDC	29.07.98	KÜ.	Bart.
				B	CLARIFICATION	14.02.01	OFL.	Bart.
				C	Anpassung ans Werkzeug und Prod.- Zeichnung	15.02.01	OFL.	Bart.

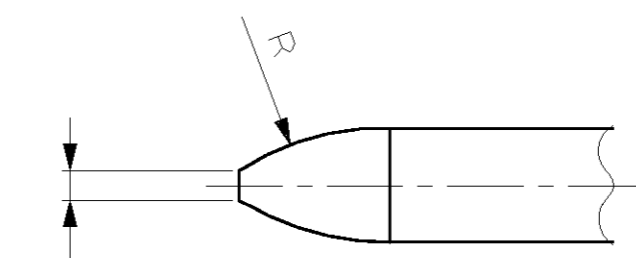
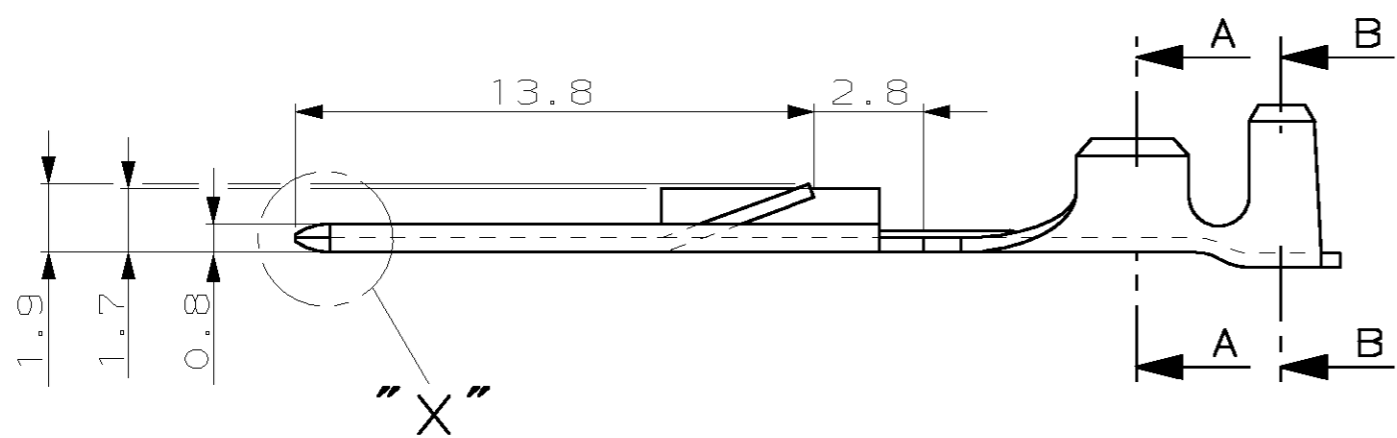

Einzelheit "X"  
M 20:1

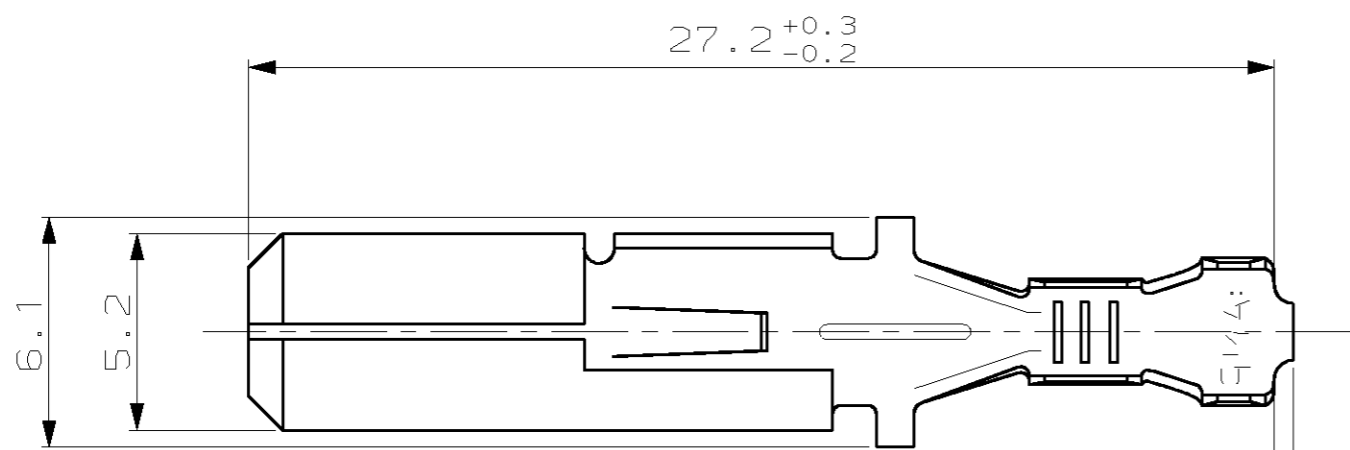

REMARKS  
Bemerkungen

1 FUNCTION SIMILAR PN 964 244, BUT DIFFERENT APPLICATORS  
Funktional ähnlich wie PN 964 244, aber diverse Applicatoren

2 TAB EXTRACTION TOOL  
PN 726 944  
Tab. Entriegelungswerkzeug  
PN 726 944

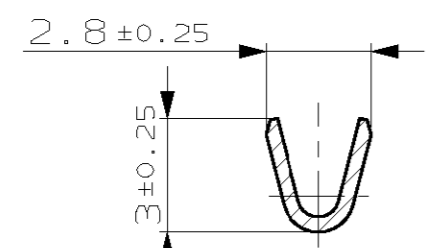

Schnitt SECTION A-A

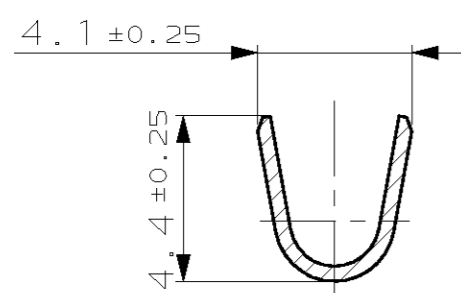

Schnitt SECTION B-B

-	0-969 031-3	--	--	5.2 Tab	CuZn30	SILVER
-	0-969 031-2	--	--	5.2 Tab	CuZn30	PRETINNED
-	0-969 031-1	--	--	5.2 Tab	CuZn30	NONE

DGB	LOOSE PIECE BESTELL-NR.	BESTELL-NR.	POS.	STÜCK	BENENNUNG EINZELTEIL	WERKSTOFF	OBERFLÄCHE FARBE
0.5-1.0mm <sup>2</sup>	THIS DRAWING IS A CONTROLLED DOCUMENT FOR AMP INCORPORATED. IT IS SUBJECT TO CHANGE AND THE CONTROLLING ENGINEERING ORGANIZATION SHOULD BE CONTACTED FOR THE LATEST REVISION. DIESSES ZEICHNUNGSDOKUMENT WIRD DURCH AMP INCORPORATED KONTROLLIERT. ÄNDERUNGEN, DIE DEM TECHNISCHEN FORTSCHRITT DIENEN, SIND VORBEHALTEN. DEN JEWEILS LETZTGÜELTIGEN ÄNDERUNGSSTAND ERFAHREN SIE AUF ANFRAGE.		DWN R.Schwan 11.12.95	CHK G.Bartosch 11.12.95	APVD H.Bitsch 11.12.95	AMP Deutschland GmbH D - 63225 Langen	
Isol. ø	DIMENSIONS: DIMENSIONEN: mm	TOLERANCES UNLESS OTHERWISE SPECIFIED: ALLGEMEINTOLERANZEN n. ISO 8015 n. ISO 2768 - mH -E n. DIN 16901 - 140	PRODUCT SPEC VERARBEITUNGSSPEZ.		5.2 x 0.8 POSITIVE MATE TAB		
ø2.0-2.7mm	MATERIAL	ANGLES /WINKEL ±1° FINISH /OBERFLÄCHE/FARBE	APPLICATION SPEC VERARBEITUNGSSPEZ.		SIZE A3	CAGE CODE 00779	DRAWING NO ZEICHNUNGS-NR. C-969031
SEE TABLE	SEE TABLE	SEE TABLE	WEIGHT GEWICHT -		RESTRICTED TO NUR FUER -		
CUSTOMER DRAWING /KUNDENZEICHNUNG		MASSSTAB (20:1) 5:1	BLATT 1 OF 1	REV C			