

REVISIONS				
P.	LTN	DESCRIPTION	DATE	APPV
	A	NEW DRAWING	18AUG2014	MN XR

MODULE	REP. /	QTE. /	MATIERE /	COULEUR /	REF / PN TE
34 VOIES	ITEM	QTY.	MATERIAL	COLOR	
2	1		PBT 20% FV	NOIR X130	953222-1
1	8		INOX DORURE SELECTIVE 0.1 a 0.3 micron AU	-	

PIECE A UTILISER AVEC :
 CONNECTEUR 50 VOIES MOS STANDARD DONT 8 SHUNTS : 953221-X
 CLIP MOS REF : 144969-X

FOR USE WITH:
 SHIELD + LEVER FOR MOS 50 POS WITH 8 SHORT CIRCUIT: 953221-X
 MOS RECEPTACLE: 144969-X

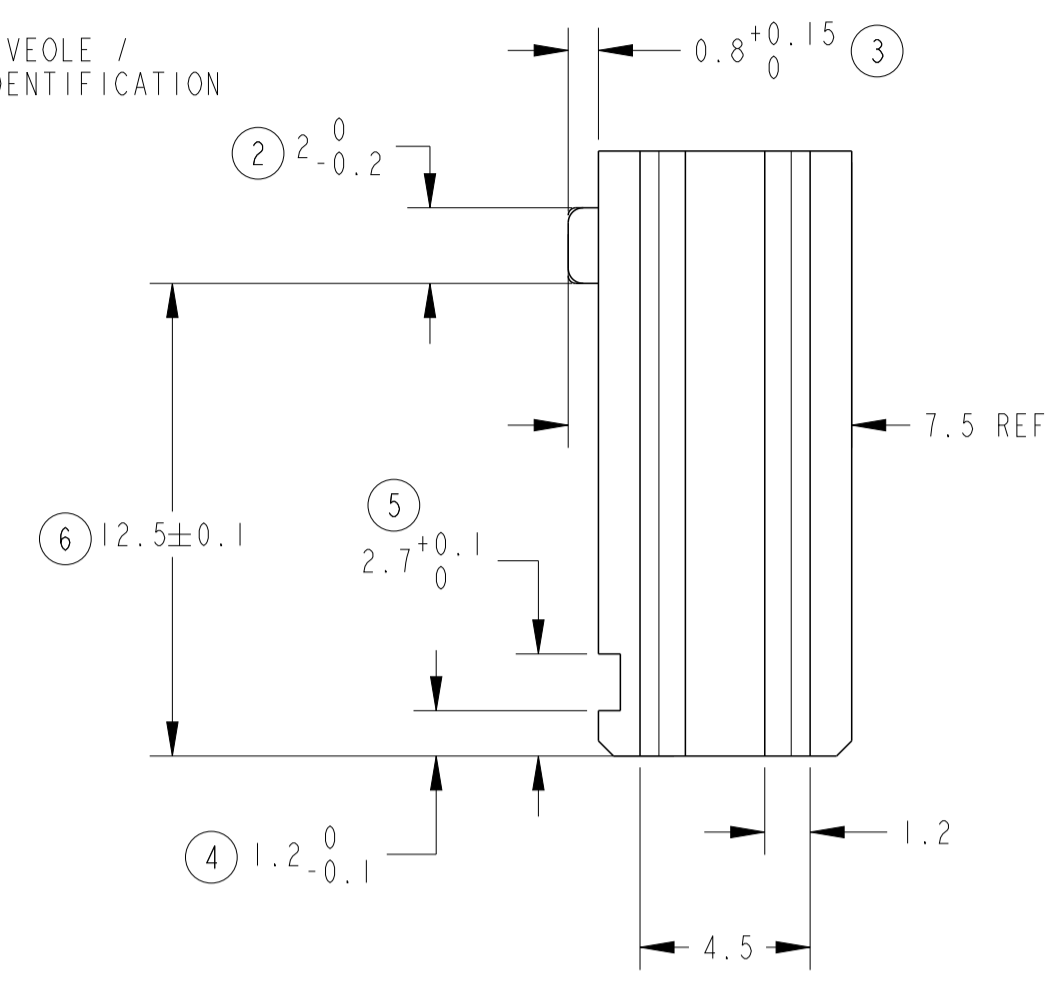
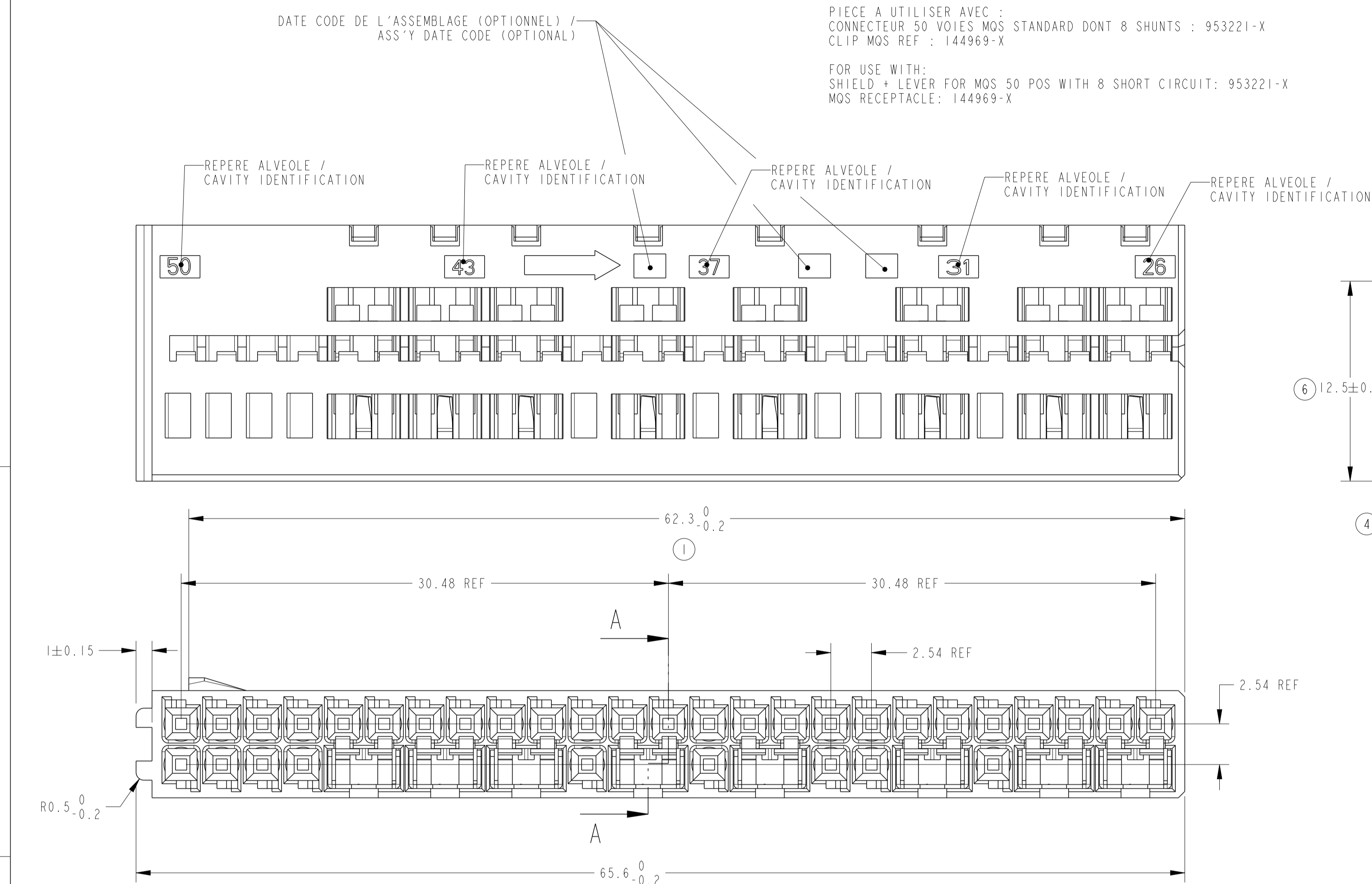

COUPE / SECTION A-A
 ECHELLE / SCALE 10:1

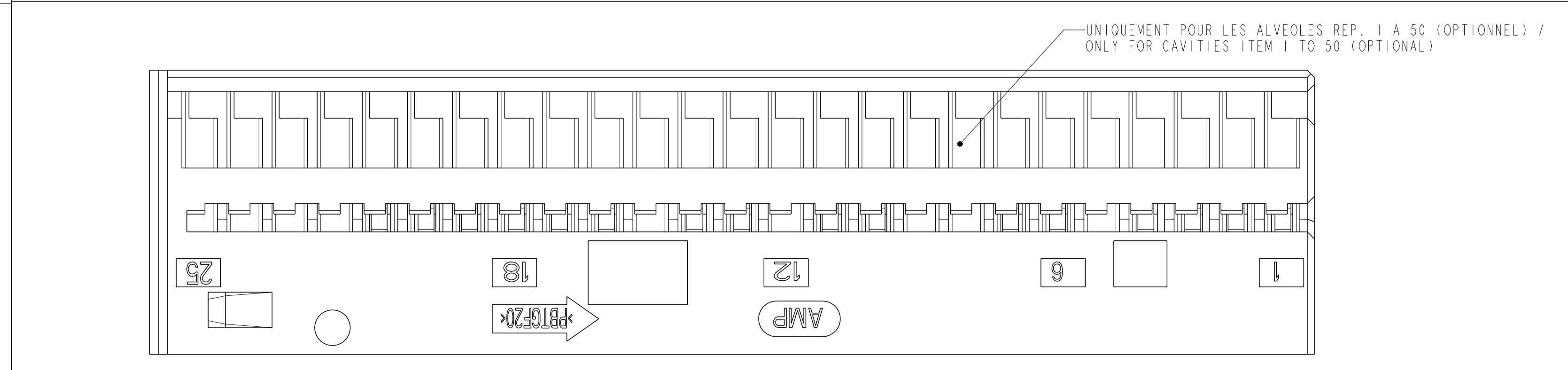
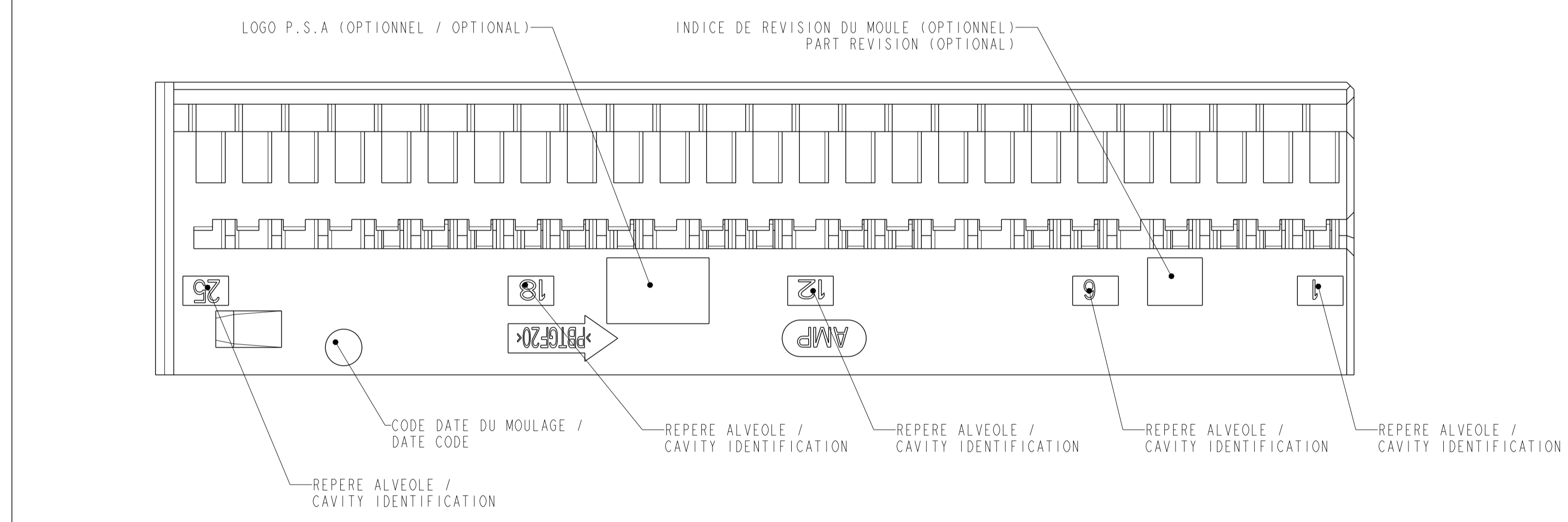
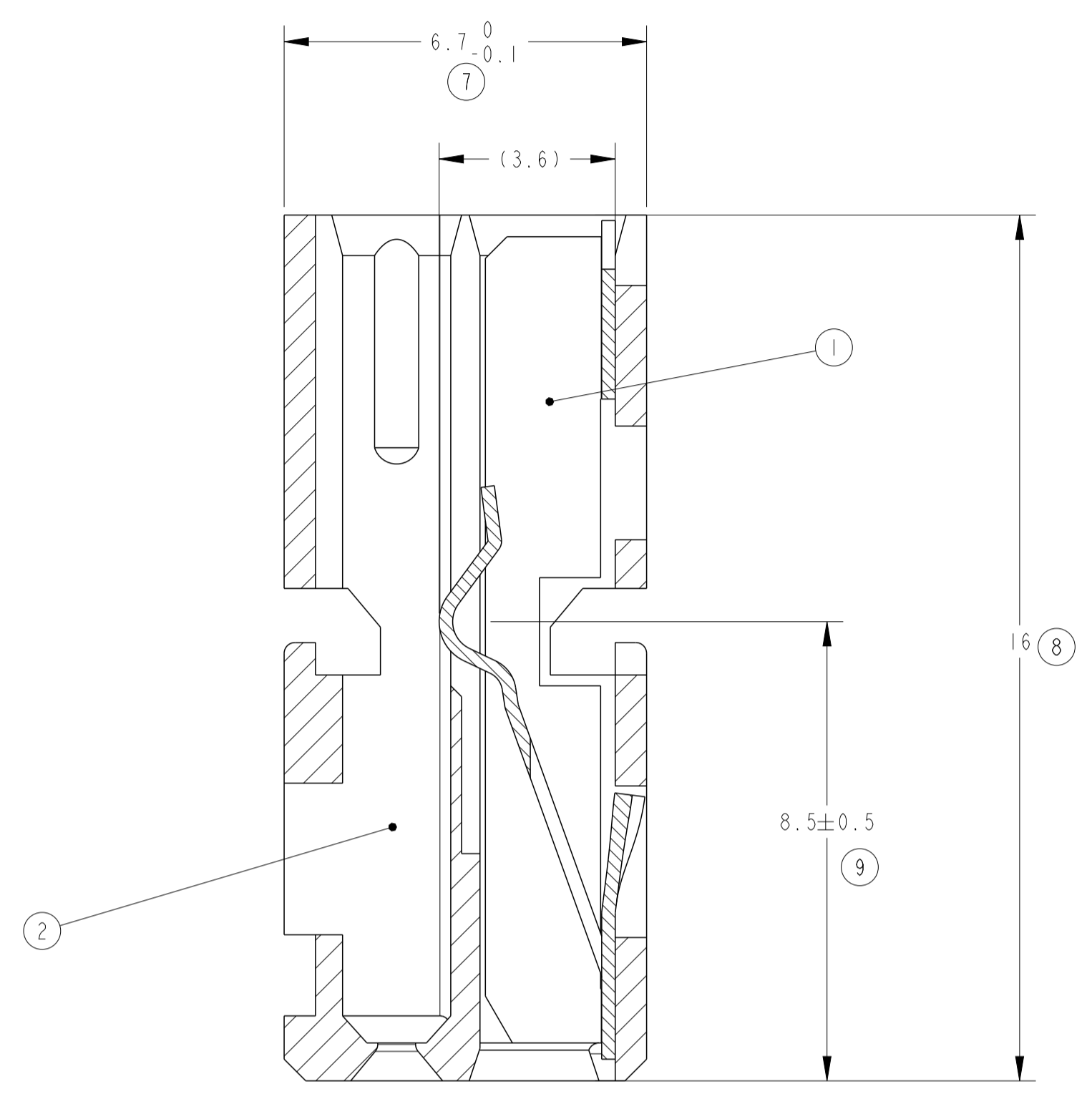

THIS DRAWING IS A CONTROLLED DOCUMENT.
 CE PLAN EST UN DOCUMENT CONTROLÉ PAR AMP INCORPORATED.
 IL EST SOUS LE CONTROLE DE LA DIVISION PRODUIT ET/OU DE LA DIVISION REVISION.
 DIMENSIONS: mm

TOLERANCES UNLESS OTHERWISE SPECIFIED:
 0 SUIVY NB DE DECIMALES:
 1 PLC/DEC: ±0.2
 2 PLC/DEC: ±0.2
 3 PLC/DEC: ±0.2
 4 PLC/DEC: ±0.2
 ANGLES: ±5°

MATERIAL/MATIERE: SEE TABLE / VOIR TABLEAU

FINISH/FINITION: -

DMN/DESSINE: MADHUSUDHAN N
 CHK/VERIFIE: Y. ROUILLARD
 APVD/APPROUVE: Y. ROUILLARD
 PRODUCT SPEC: 108-15188
 SPEC. APPLICATION: 411-15601

DATE: 18AUG2014

NAME/TITRE: MODULE 50 VOIES MOS STANDARD DONT 8 SHUNTS MOS 50 POS SOCKET HOUSING WITH 8 SHORT CIRCUIT

SIZE: A1

CAGE CODE: -

DRAWING NO: 953222

RESTRICTED TO: RESERVE A

CUSTOMER DRAWING / PLAN CLIENT

UNIQUEMENT POUR REFERENCE / SCALE: 5:1

SHEET OF: 1 OF 1

FEUILLE DE: 1 DE 1

REV: A