

THIS SPECIFICATION SHEET FORMS A PART OF THE LATEST ISSUE OF RAYCHEM SPECIFICATION 1200.

CONSTRUCTION DETAILS

DIMENSIONS ARE NOMINAL VALUES IN INCHES UNLESS OTHERWISE DESIGNATED.

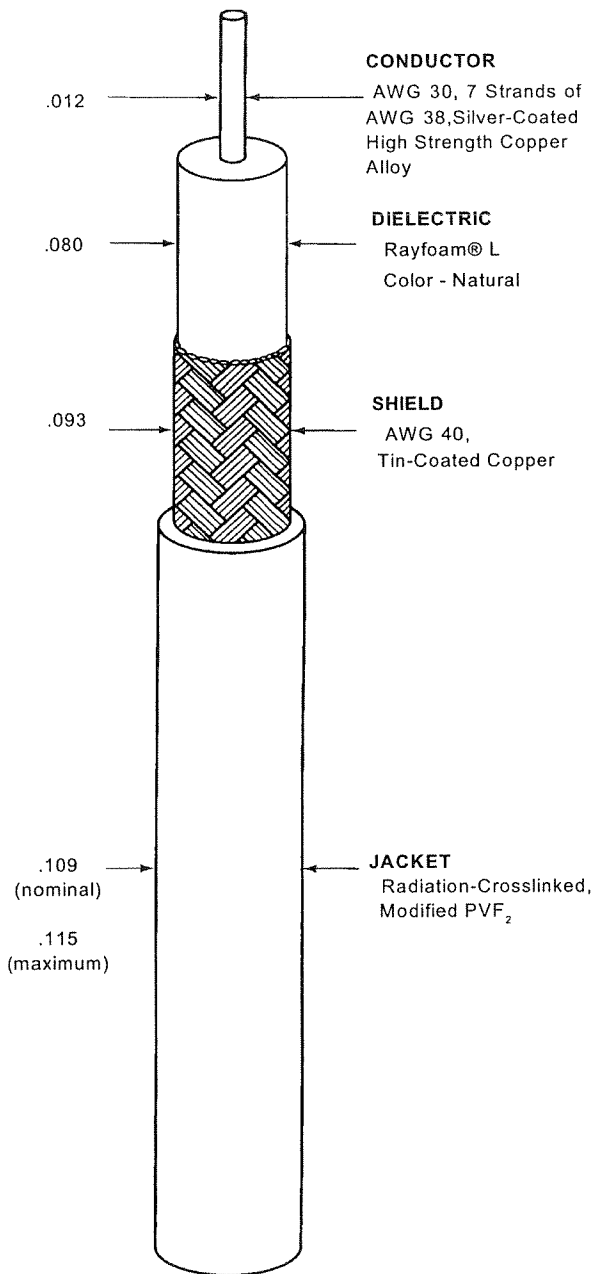

ELECTRICAL CHARACTERISTICS

CHARACTERISTIC IMPEDANCE	95 ± 5 ohms, Method B
CAPACITANCE	13.5 pF/ft. (nominal) at 1 KHz
VELOCITY OF PROPAGATION	78% (nominal)

ADDITIONAL REQUIREMENTS

ELECTRICAL

CONDUCTOR RESISTANCE	116 ohms/1000 ft. (nominal)
INSULATION RESISTANCE	10,000 megohms (minimum) or 1000 ft.
JACKET FLAWS	
SPARK TEST	1.0 kV (rms)
IMPULSE TEST	6.0 kV (peak)
VOLTAGE WITHSTAND (DIELECTRIC)	1000 volts (rms), (minimum)

ENVIRONMENTAL

FLAMMABILITY	Method B
HEAT SHOCK	225°C
LOW TEMPERATURE-COLD BEND	-55°C/3.00 inch mandrel
VOLTAGE WITHSTAND (POST ENVIRONMENTAL)	1000 volts (rms), 1 minute

PHYSICAL

INSULATION (DIELECTRIC)	
ELONGATION	50% (minimum)
TENSILE STRENGTH	1000 lbf/in ² (minimum)
JACKET	
ELONGATION	200% (minimum)
TENSILE STRENGTH	4000 lbf/in ² (minimum)
JACKET THICKNESS	.006 inch (minimum) .008 inch (nominal)
SHIELD COVERAGE	90% (minimum)

WEIGHT 7.0 lbs/1000 ft. (nominal)

Outer jacket color will be white (designated by a "9" appended to the part number, e.g., 9530D1114-9) unless otherwise specified.

Designate outer jacket color with a dash number in accordance with MIL-STD-681.