

THIS DRAWING IS UNPUBLISHED. RELEASED FOR PUBLICATION 2005
 © COPYRIGHT 2005 BY TYCO ELECTRONICS CORPORATION. ALL RIGHTS RESERVED.

LOC	DIST	REVISIONS					
		P	LTR	DESCRIPTION	DATE	DWN	APVD
A1	-						

ERGOCRIMP DIE SET FOR MCON 2.8LL TERMINALS - 4,0 mm²

Ergocrimp Matrize als Ersatzteil erhaeltlich
 PN 9-1579021-3
 Ergocrimp die set as spare part available
 PN 9-1579021-3

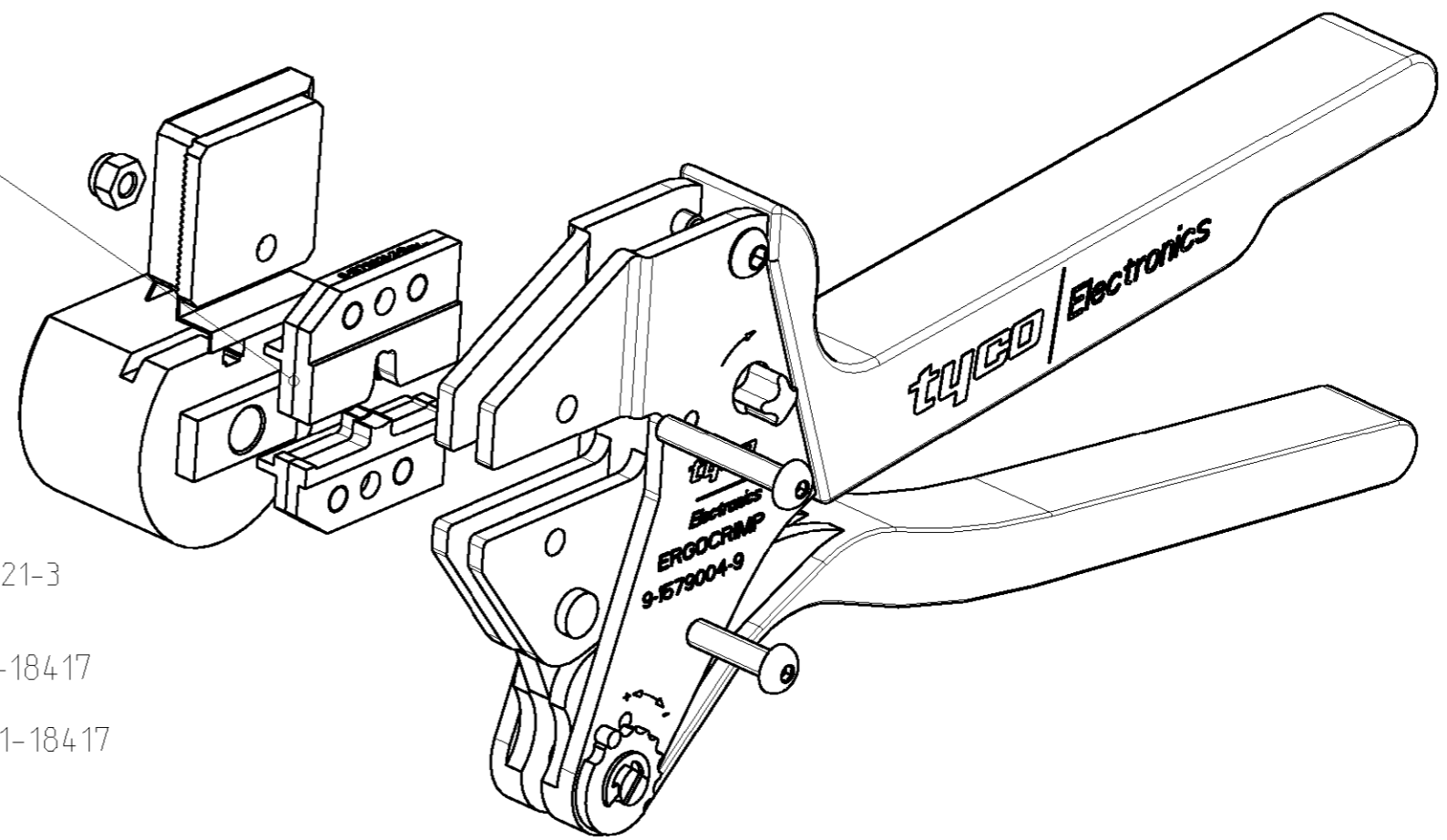

Einzelzeile der Ergocrimp Matrize bestellbar. Siehe Zeichnung PN 9-1579021-3
 Spare parts of the Ergocrimp die set are available. See drawing PN 9-15790021-3

Handzange mit Matrize zusammengebaut und mit Bedienungsanleitung 411-18417
 im Karton verpackt
 Hand tool assembled with die set and packed with instruction sheet 411-18417
 in a cardboard

Kontakt	DGB (mm ²)	Drahtcrimp / Wire Crimp		Isolationscrimp/Insulationcrimp		Isol.Ø	Betriebsanl.
Contact	Wire Range	Hoehe/Height mm	Breite/Width mm	Hoehe/Height mm	Breite/Width mm	Ins.Range	Instr.Sheet
1718477	4,0	2.25 ±0.05	3.05 F	4.35 max.	4.32 OV	3,4-3,7	411-18417

<small>THIS DRAWING IS A CONTROLLED DOCUMENT FOR TYCO ELECTRONICS CORPORATION IT IS SUBJECT TO CHANGE AND THE CONTROLLING ENGINEERING ORGANIZATION SHOULD BE CONTACTED FOR THE LATEST REVISION.</small>		DWN Ch.Witt 26APR2007 CHK - APVD - PRODUCT SPEC - APPLICATION SPEC - WEIGHT 750 g		tyco Electronics tyco Electronics AMP GmbH D - 64625 Bensheim	
DIMENSIONS: mm 		TOLERANCES UNLESS OTHERWISE SPECIFIED: 0 PLC ± 1 PLC ± 2 PLC ± 3 PLC ± 4 PLC ± ANGLES ±1° MATERIAL - FINISH -		NAME ERGOCRIMP HAND TOOL FOR MCON 2.8LL TERMINAL 4,0 mm ²	
CUSTOMER DRAWING		SIZE A3	CAGE CODE 00779	DRAWING NO C-9-1579004-9	RESTRICTED TO -
SCALE 5:1			SHEET 1 OF 1	REV A	