

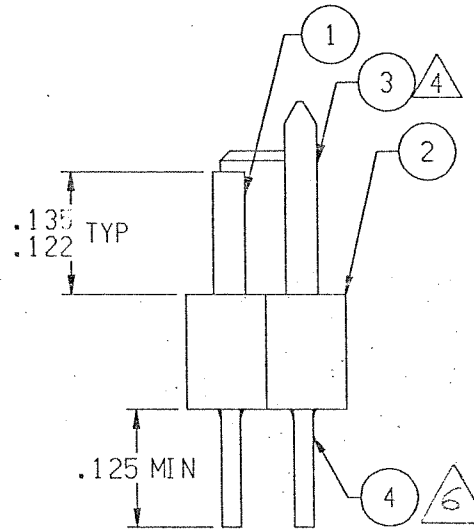

REVISION					
ZONE	LTR	ECN	DESCRIPTION	DATE	APPROVED
	A	35791	NEW RELEASE	9/28/95	EL
	B	35860	ADD NOTE 6	9/16/95	EL

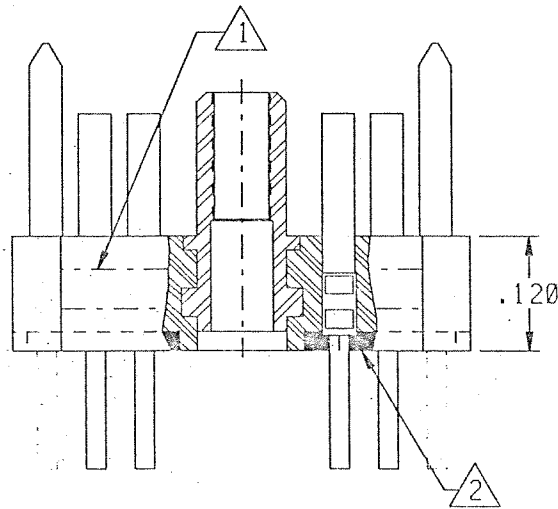
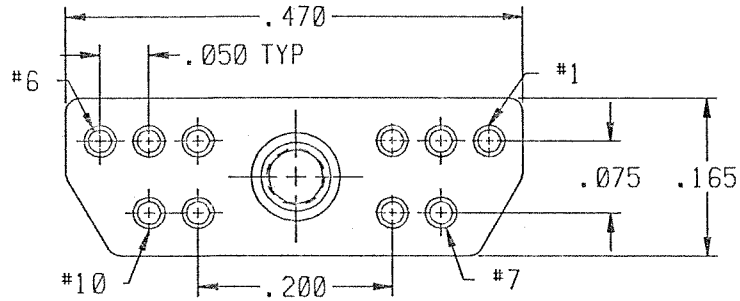

Tyco Dwg 9-1532019-2
Micro P/N 095-0573-0936

NOTES: UNLESS OTHERWISE SPECIFIED

- ① MARK "MICRODOT" OR MICRODOT LOGO, PART NUMBER & DATE CODE USING .047 MIN. HIGH CHARACTERS IN APPROXIMATE LOCATION SHOWN.
- ② EPOXY AS SHOWN USING HYSOL 4215 & 3561.
- 3. CRIMP LEADS INTO CONTACTS PER MEP 302-05.
- ④ GUIDE PIN IN CAV'S 1 & 6.
- 5. EPOXY WICKING ON LEADS - .050 MAX.
- ⑥ TERMINAL WIRES TO BE SOLDER DIPPED.

UNLESS OTHERWISE SPECIFIED DIMENSIONS ARE IN INCHES. TOLERANCE ARE: FRACTIONS DECIMALS ANGLES $\pm 1/8$.XX $\pm .01$ $\pm 2^\circ$.XXX $\pm .005$	APPROVALS		 MICRODOT CONNECTORS A DIVISION OF UNI-STAR INDUSTRIES INC. 306 PASADENA AVE., SO. PASADENA, CA 91030	PROD CODE 834 CODE M
	SIGNATURE	DATE		
	CHECKED			
	APPROVED	<i>EL</i>		
MATERIALS:	DRAWN: <i>KE F. CAMPOS</i> 9/28/95 CHECKED: PROD. ENG.: APPROVED:		JACKMATE CONNECTOR MCJG1-10S6L5-0.125	
FINISH:	THIS DOCUMENT IS THE PROPERTY OF MICRODOT CONNECTORS, A DIVISION OF UNI-STAR INDUSTRIES INC. USE OF THIS DOCUMENT OR ANY PART THEREOF IS STRICTLY FORBIDDEN WITHOUT EXPRESS WRITTEN PERMISSION OF MICRODOT CONNECTORS, A DIVISION OF UNI-STAR INDUSTRIES INC.		SIZE: A CODE IDENT NO.: 98278 SCALE: X 5	DRAWING NO.: 095-0573-0936 SHEET 1 OF 1