

P	LTR	DESCRIPTION	DATE	DWN	APVD
A		INITIAL RELEASE	21 JUN 2021	DC	EO

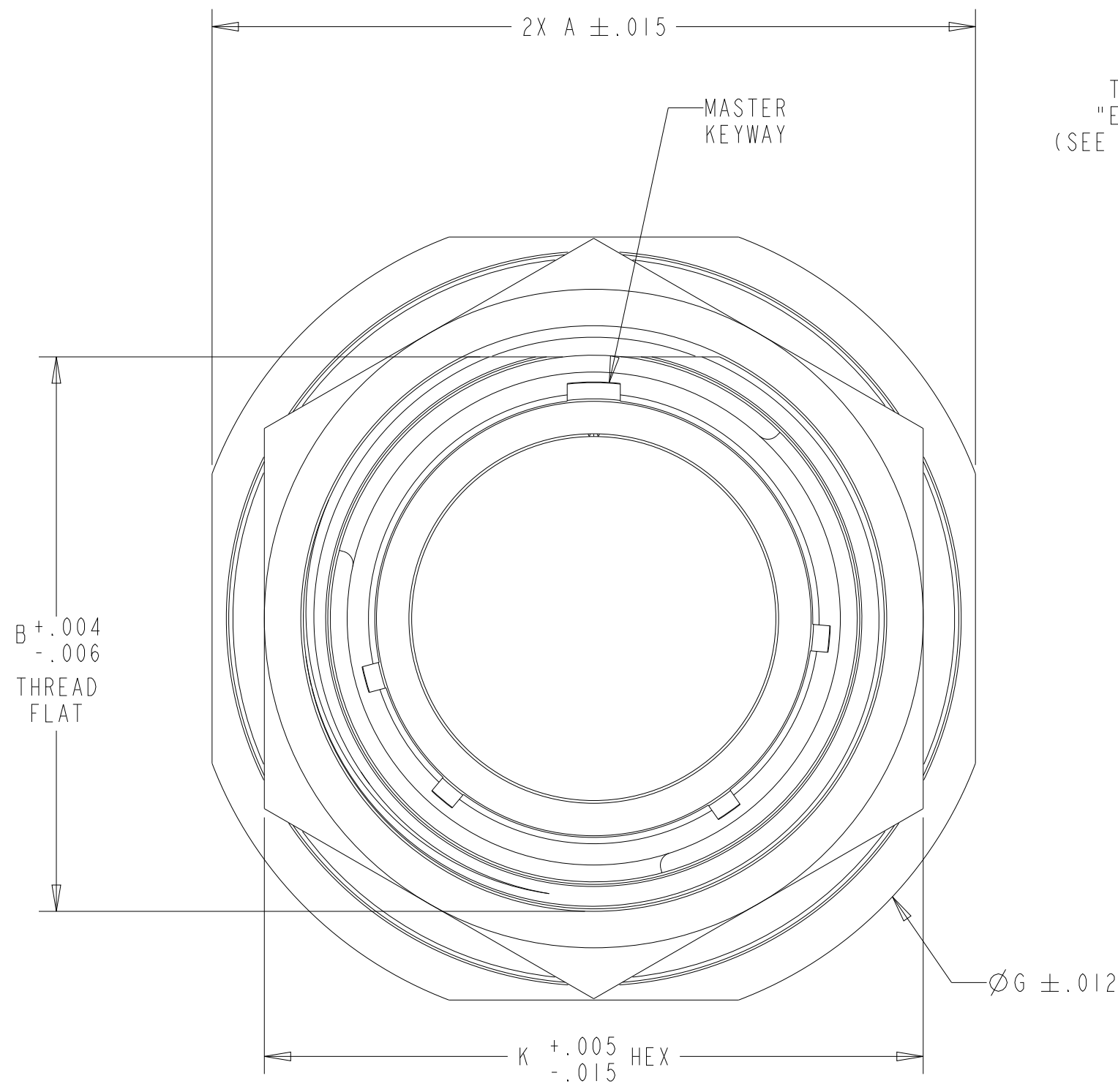

STUB 60° MOD.
TRIPLE START THREAD
"E" - .1P - .3L CLASS 2A
(SEE COLUMN "E THREAD")

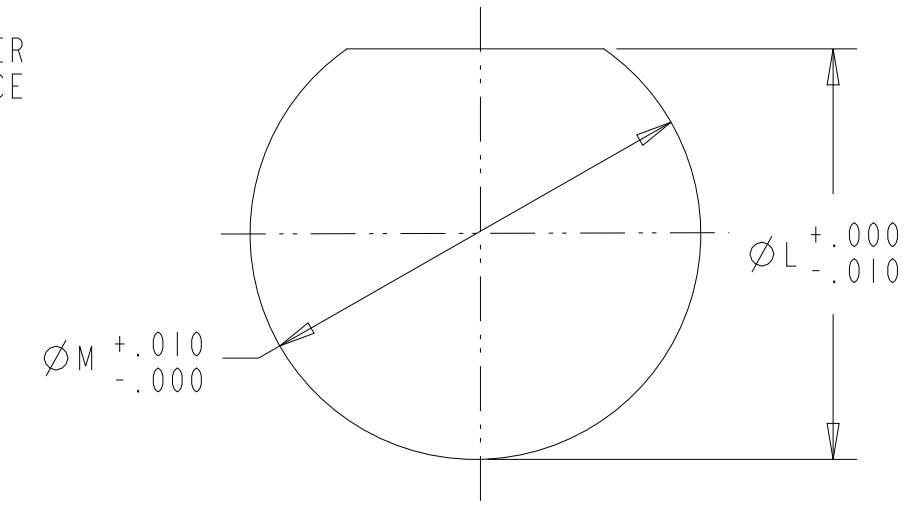
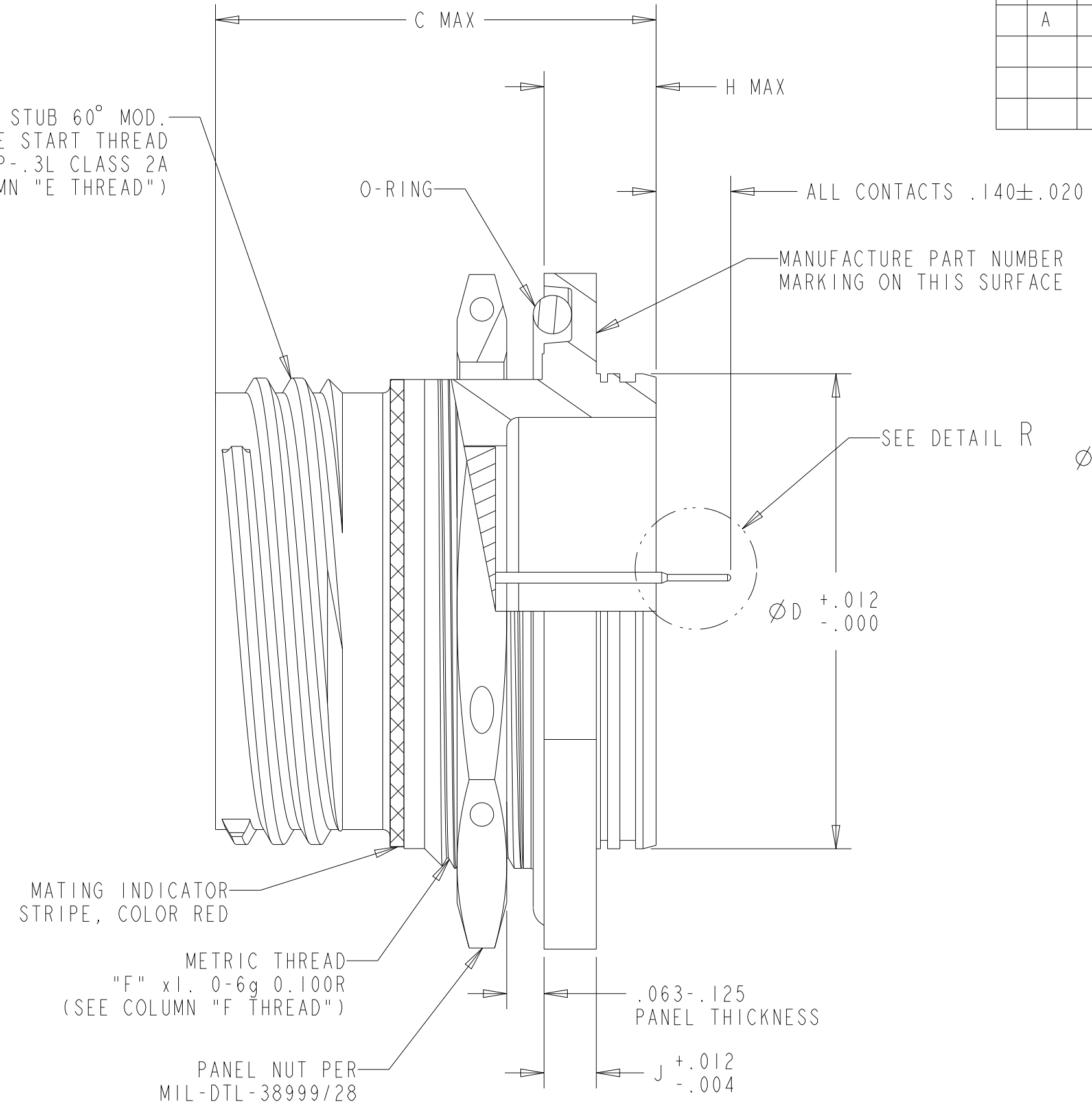

RECOMMENDED PANEL CUT OUT

SHELL SIZE	L	M
19	1.335	1.385
21	1.460	1.510

PART NUMBER BREAKDOWN EXAMPLE: 72362-19-35PN

- SHELL KEYING POSITIONS: N, A, B, C, D OR E
- CONTACT PIN STYLE: FEEDTHRU PIN
- INSERT ARRANGEMENT
- SHELL SIZE: 9, 11, 13, 15, 17, 19, 21, 23 OR 25
- BASIC IDENTIFIER: SPECIAL SERIES PART NUMBER 38999 SERIES III TYPE, HERMETIC RECEPTACLE

SHELL SIZE	A	B	C	D	E THREAD	F THREAD	G	H	J	K
19	1.811	1.312	1.185	1.268	1.2500	M35	1.937	.382	.134	1.563
21	1.937	1.437	1.185	1.394	1.3750	M38	2.063	.382	.134	1.750

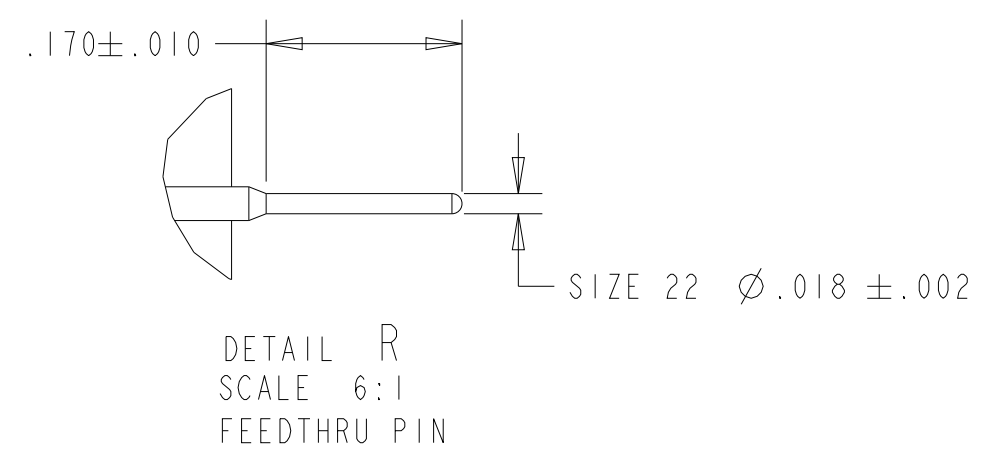

NOTE(S):

1. DIMENSIONS ARE IN INCHES UNLESS OTHERWISE NOTED.
2. INSERT ARRANGEMENT CONFORMS TO MIL-STD-1560.
3. LEAK RATE THROUGH GLASS INSERT: <1E-8 cc/sec He @ 1 atm.

- 4 FINISH: SHELL - ELECTRO-POLISH (PASSIVATED)
PIN CONTACTS - GOLD OVER NICKEL
- 5 MATERIAL: SHELL & JAM NUT - STAINLESS STEEL
PIN CONTACTS - HIGH NICKEL IRON ALLOY OR EQUIVALENT
GLASS - COMPRESSION GLASS
INTERFACIAL SEAL & O-RING - FLUOROSILICONE ELASTOMER
- 6. MATES WITH DTS26 SERIES PLUG CONNECTOR.

MC: 72 FINISH: 4

DESCRIPTION:

ENVELOPE
CONNECTOR RECEPTACLE
JAM NUT MOUNT
THREAD COUPLING
MIL-DTL-38999 SERIES III TYPE
HERMETIC

CAGE CODE: 11139

THIS DRAWING IS A CONTROLLED DOCUMENT.

DWN: DAVID CALVARIO 21 JUN 2021
CHK: ENRIQUE OCHOA 21 JUN 2021
APVD: ENRIQUE OCHOA 21 JUN 2021

NAME: ENRIQUE OCHOA

PRODUCT SPEC: -
APPLICATION SPEC: -
WEIGHT: -

SIZE: A2 CAGE CODE: 00779 DRAWING NO: 72362-xx-xxPx RESTRICTED TO: -

CUSTOMER DRAWING SCALE: 1:1 SHEET: 1 OF 1 REV: A