

P	LTR	DESCRIPTION	DATE	DWN	APVD
	A	INITIAL RELEASE	04MAY2021	SM	NA

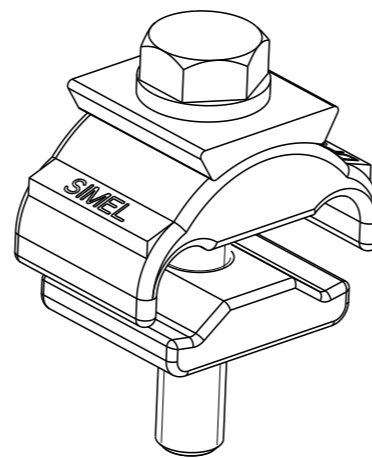

SCALE 3:2

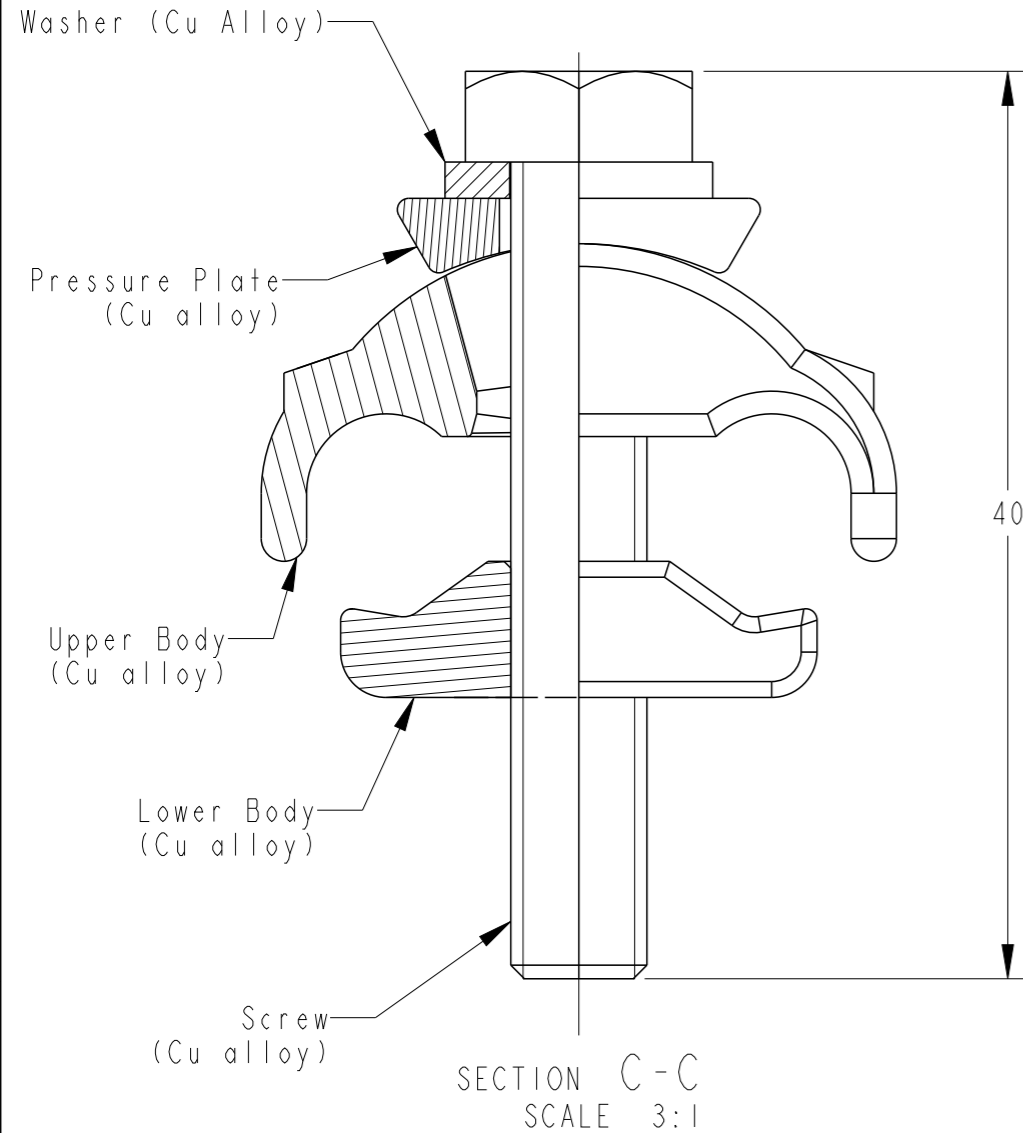
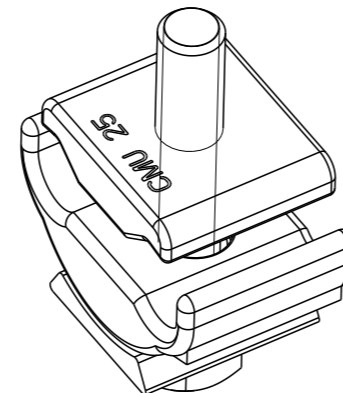

EHELLE 3:2

Notes:

1. Capacities: 6 to 25 mm² Main and Tap
2. Marking: Batch number (week and year of manufacturing)

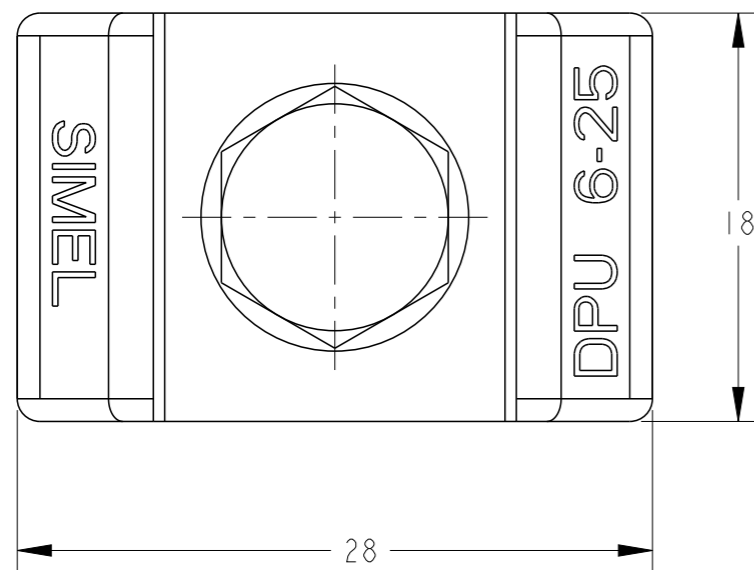

DPU 6-25U	708989-1
DESCRIPTION	TCPN

THIS DRAWING IS A CONTROLLED DOCUMENT.		DWN SATYA.M 04MAY2021												
DIMENSIONS: mm		CHK L. JONATHAN 04MAY2021												
TOLERANCES UNLESS OTHERWISE SPECIFIED:		APVD N. ALMEDIA 04MAY2021												
<table border="1"> <tr> <td>0 PLC</td> <td>±-</td> </tr> <tr> <td>1 PLC</td> <td>±-</td> </tr> <tr> <td>2 PLC</td> <td>±-</td> </tr> <tr> <td>3 PLC</td> <td>±-</td> </tr> <tr> <td>4 PLC</td> <td>±-</td> </tr> <tr> <td>ANGLES</td> <td>±-</td> </tr> </table>		0 PLC			±-	1 PLC	±-	2 PLC	±-	3 PLC	±-	4 PLC	±-	ANGLES
0 PLC	±-													
1 PLC	±-													
2 PLC	±-													
3 PLC	±-													
4 PLC	±-													
ANGLES	±-													
MATERIAL -		PRODUCT SPEC -	SIZE A3	CAGE CODE 00779	DRAWING NO C-708989	RESTRICTED TO -								
FINISH -		APPLICATION SPEC -	WEIGHT 45 g		SCALE 1:1	SHEET 1 OF 1	REV A							
-		CUSTOMER DRAWING												