

THIS DRAWING IS UNPUBLISHED. RELEASED FOR PUBLICATION  
 © COPYRIGHT - By - ALL RIGHTS RESERVED.

REVISIONS				
P	LTR	DESCRIPTION	DATE	APVD
P1		REVISED PER ECO-16-001847	19JUL2016	NK MZ

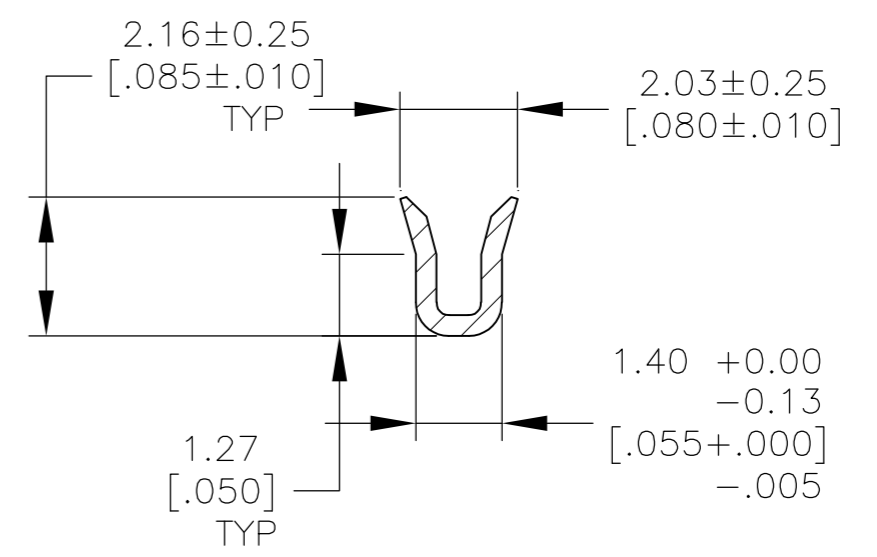

SECTION A-A

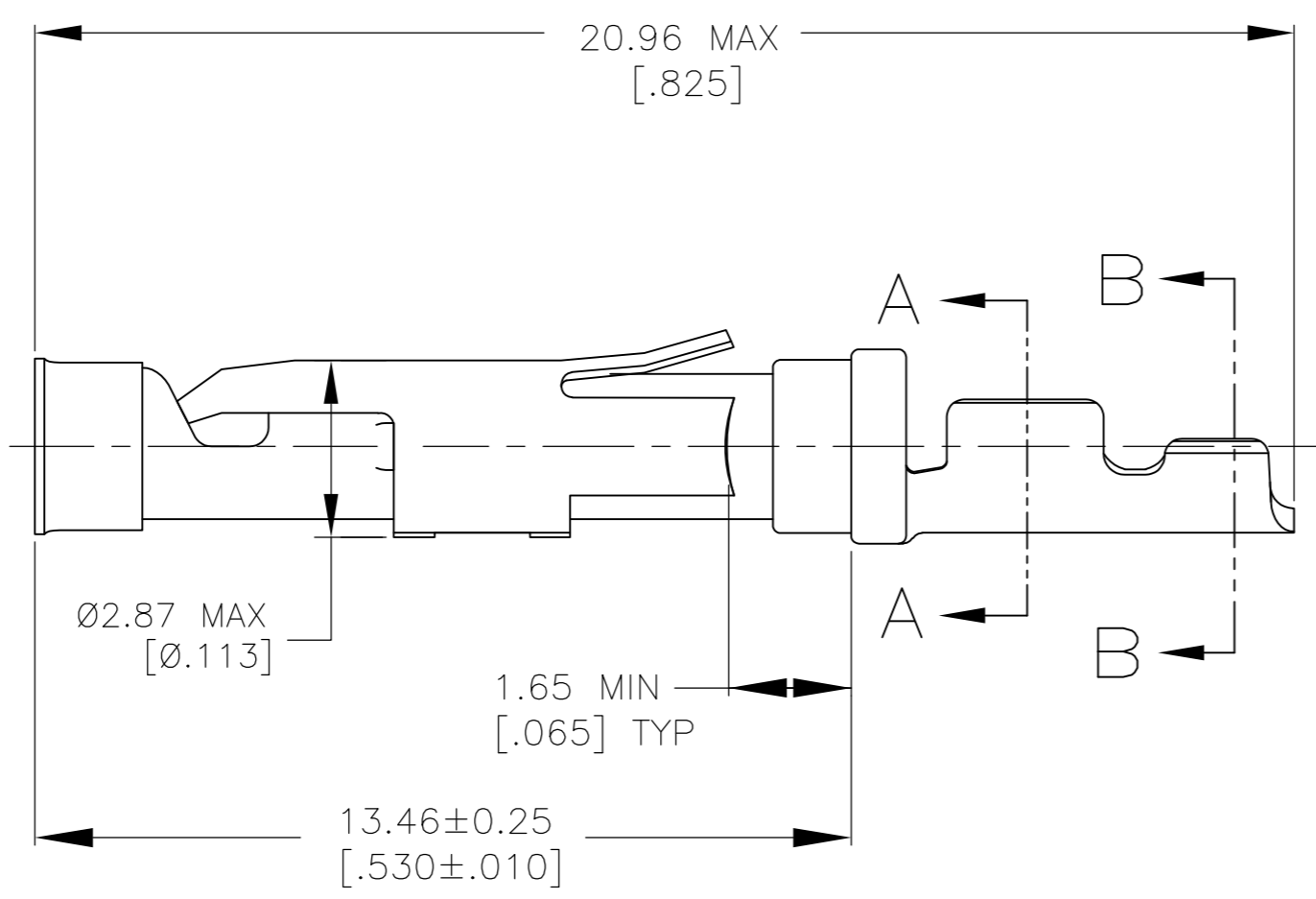
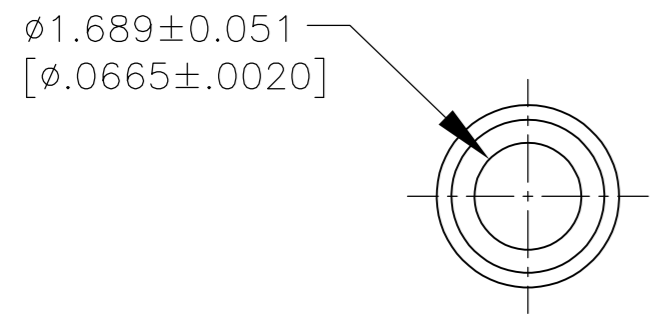
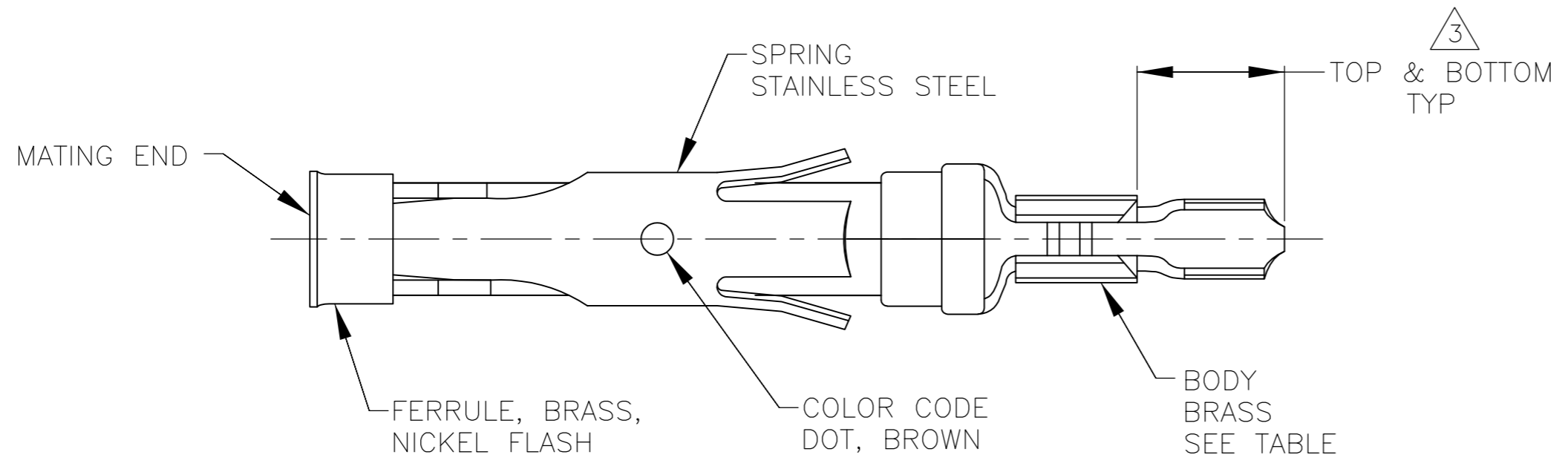
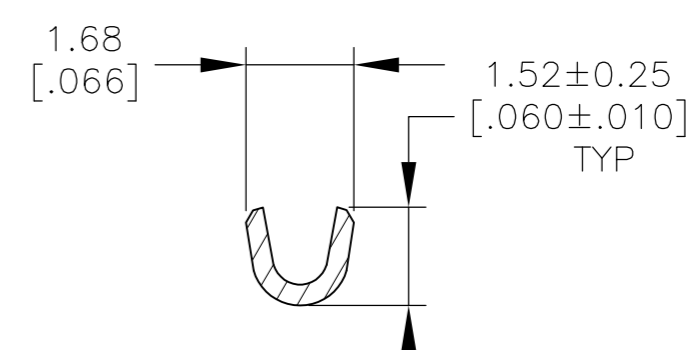

SECTION B-B

- 1 0.76 $\mu$ m [.000030] MIN GOLD PER MIL-G-45204 ON MATING END FOR A LENGTH OF 5.08 [.200] MIN WITH 1.27 $\mu$ m [.000050] MATTE TIN PLATE IN WIRE CRIMP AREA, BOTH OVER 0.76 $\mu$ m [.000030] MIN NICKEL PER QQ-N-290.
- 2 0.76 $\mu$ m [.000030] MIN GOLD PER MIL-G-45204 ON MATING END FOR A LENGTH OF 5.08 [.200] MIN WITH A UNIFORM GRADIENT TO 0.25 $\mu$ m [.000010] MIN GOLD PER MIL-G-45204 ON THE REMAINDER OVER 0.76 $\mu$ m [.000030] MIN NICKEL PER QQ-N-290.
- 3 GOLD PLATING NEED NOT APPEAR IN THIS AREA.
- 4 WIRE RANGE 26-30 AWG. INSULATION RANGE 0.36[.014]-0.76[.030].
- 5 0.38 $\mu$ m [.000015] MIN GOLD PER MIL-G-45204 ON MATING END FOR A LENGTH OF 5.08 [.200] MIN, 1.27 $\mu$ m [.000050] MIN TIN-LEAD PER MIL-T-10727 FOR A LENGTH OF 5.69 [.224] MIN ON OPPOSITE END, BOTH OVER 1.27 $\mu$ m [.000050] MIN NICKEL PER QQ-N-290 ON ENTIRE CONTACT.

OBSOLETE	5	1-66394-4	66405-8
	1	66394-4	66405-4
OBSOLETE	2	66394-1	66405-1
	BODY FINISH	STRIP P/N REF	PART NO

THIS DRAWING IS A CONTROLLED DOCUMENT.		DWN R.SHIREY 7-30-91		
DIMENSIONS: mm [INCHES]		CHK R.STONE 9-19-91		
TOLERANCES UNLESS OTHERWISE SPECIFIED:		APVD -	NAME	
0 PLC ± -		PRODUCT SPEC -	SOCKET ASSEMBLY, LOOSE PIECE, TYPE III+	
1 PLC ± -		APPLICATION SPEC -	SIZE A2	CAGE CODE 00779
2 PLC ± 0.13[.005]		WEIGHT -	DRAWING NO C-66405	RESTRICTED TO -
3 PLC ± -		CUSTOMER DRAWING	SCALE 8:1	SHEET 1 of 1
4 PLC ± -			REV P1	
ANGLES ± -				
FINISH SEE CALLOUTS				