

REVISIONS					
P	LTR	DESCRIPTION	DATE	DMN	APVD
N3		REVISED PER ECR-20-100621	29OCT2020	PC	SW

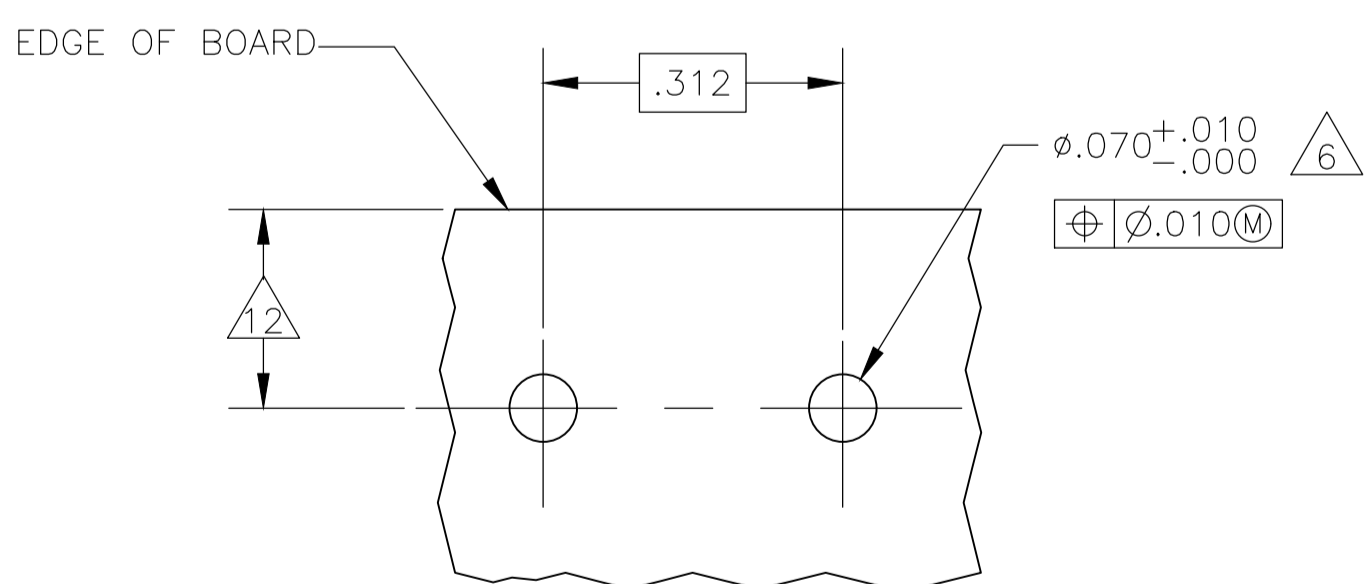
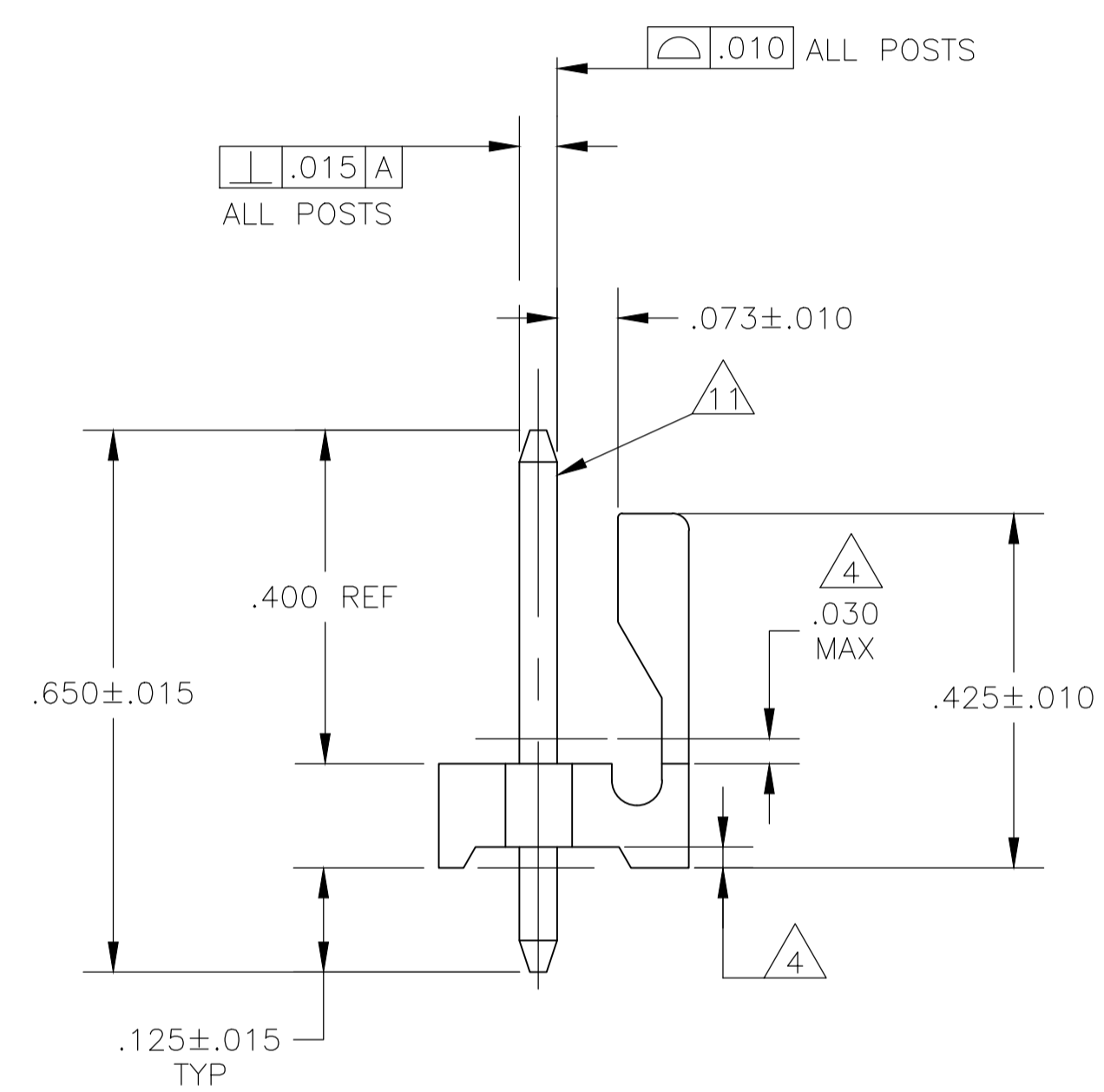
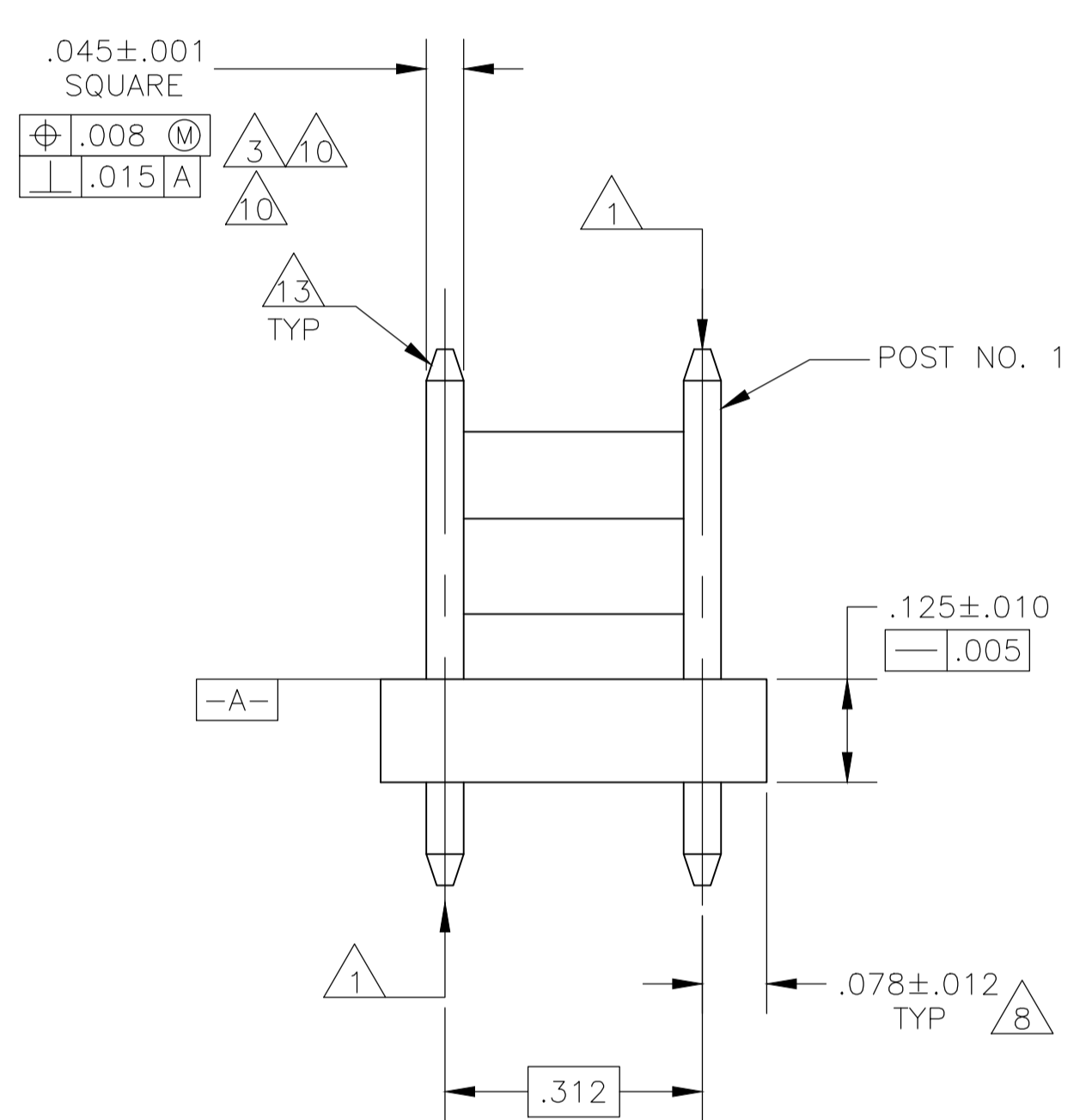
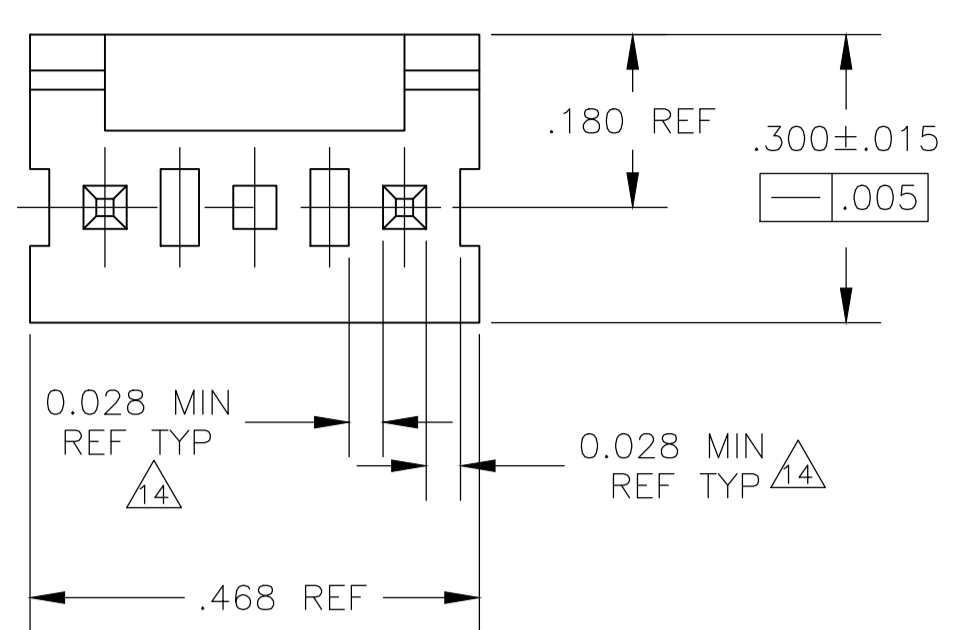

RECOMMENDED MOUNTING HOLE PATTERN FOR .063 THICK P.C. BOARD

- 1 POST TO WITHSTAND 13 NEWTONS (3LBS.) MIN. AXIAL FORCE IN BOTH DIRECTIONS SHOWN WITHOUT DISLODGING.
- 2 TOLERANCES APPLY TO SOLDER SIDE OF BOARD.
- 3 MEASURED AT SURFACE -A-
- 4 PLASTIC FLASH PERMITTED IN THIS AREA.
- 5 PARTS COMPLY WITH AMP SOLDERABILITY SPEC. NO. 109-11-2.
- 6 ONE HOLE MAY BE UNDERSIZED (.065/.060 DIA.) FOR ASSEMBLY RETENTION DURING WAVE SOLDERING.
- 7 MATERIAL: HEADER - THERMOPLASTIC POLYESTER GLASS-FILLED 94V-0 (NATURAL)
POST - COPPER ALLOY (TIN PLATED)
- 8 COORDINATE DIMENSION APPLIES FROM CENTER OF ACTUAL FEATURE.
- 9 PLASTIC BURRS CAUSED BY CUT-OFF TOOLING ARE PERMITTED WITHIN THE MAXIMUM TOLERANCE ENVELOPE.
- 10 POST TO BE MEASURED WHEN STRIP IS HELD FLAT.
- 11 POST MUST WITHSTAND TWO 90° AGAINST EXTRUSION WITHOUT BREAKING.
- 12 DIMENSION SHOULD BE .175 MIN WHEN MATING WITH A MTA-156 CONNECTOR ASSEMBLY OR A SL-156 CONNECTOR ASSEMBLY.
- 13 PIN BURR OF .005 MAX. VERTICAL AND .003 MAX. HORIZONTAL PERMITTED AT POST TIPS ON BOTH ENDS.
- 14 VALUES FOR UL 61800-5-1

Flam	RTIe deg C	HWI	HAI	CTI
V0	120	PLC1	PLC0	PLC3_UL746

		.700	17.78
.065	1.65	.468	11.89
.063	1.60	.450	11.43
.060	1.52	.425	10.80
.045	1.14	.312	7.92
.030	0.76	.300	7.62
.015	0.38	.180	4.57
.012	0.30	.175	4.45
.010	0.25	.156	3.96
.008	0.20	.125	3.18
.005	0.13	.078	1.98
.003	0.08	.070	1.78
.001	0.03	.068	1.73
[IN]	MM	[IN]	MM

CONVERSION TABLE

641937-1 SHOWN

2	641937-4
1	641937-3
3	641937-2
2	641937-1
POST NUMBER OMITTED	PART NUMBER

THIS DRAWING IS A CONTROLLED DOCUMENT.

DMN: S. HOOVER 07NOV02
CHK: D. BOSSI 07NOV02
APP'D: D. BOSSI 07NOV02

TE Connectivity Ltd.

NAME: MTA-156 HDR ASSY, FRICTN LCK, ST .045 SQUARE PST, TIN PLTD, 3 POSITION, OMITTED PST

SIZE: A1
CAGE CODE: 00779
DRAWING NO: 641937

RESTRICTED TO: -

CUSTOMER DRAWING

SCALE: 5:1 SHEET: 1 OF 1 REV: N3