

4

3

2

1

THIS DRAWING IS UNPUBLISHED.

RELEASED FOR PUBLICATION

© COPYRIGHT - TE Connectivity Ltd.

ALL RIGHTS RESERVED.

REVISIONS

P	LTR	DESCRIPTION	DATE	DWN	APVD
C2		REVISED PER ECR-17-018325	04JAN2018	BDA	SG

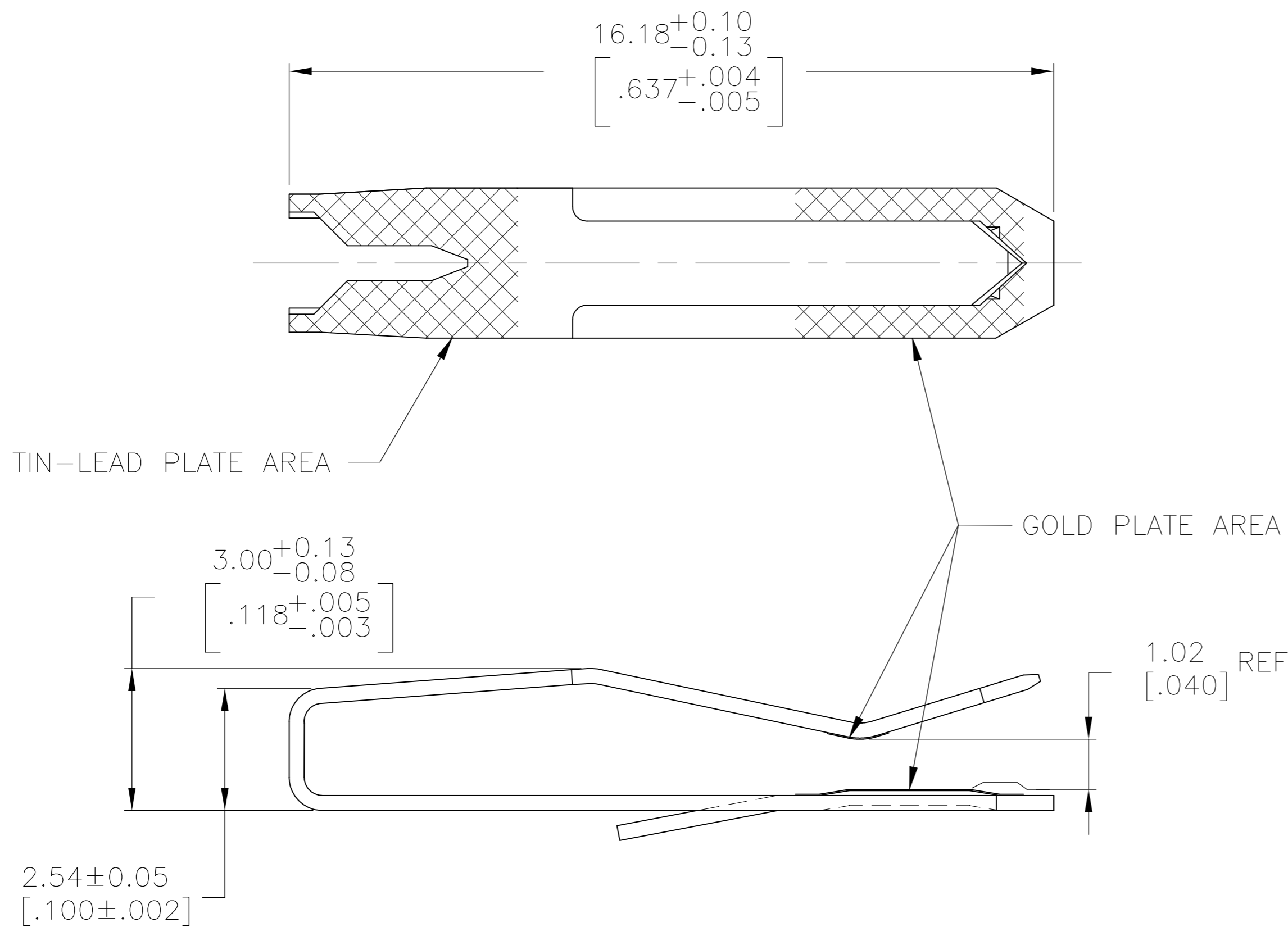

1. DIMENSIONS IN BRACKETS ARE IN INCHES.

2 0.00038 [.000015] MIN THICK GOLD IN THE GOLD PLATE AREA OVER 0.00127 [.000050] MIN THICK NICKEL.

3 0.00076 [.000030] MIN THICK GOLD IN THE GOLD PLATE AREA OVER 0.00127 [.000050] MIN THICK NICKEL.

4 0.00203 [.000080] MIN THICK TIN-LEAD IN THE TIN-LEAD PLATE AREA OVER 0.00127 [.000050] MIN THICK NICKEL.

5 MATTE TIN 0.00203(.000080) MIN THICK IN TIN PLATED AREA

6 OBSOLETE PARTS: OBSOLETE CIS STREAMLINING PER D.RENAUD/D.SINISI

	3 5	641144-4
	2 5	641144-3
OBSOLETE	3 4	641144-2
OBSOLETE	2 4	641144-1
	FINISH	PART NO

THIS DRAWING IS A CONTROLLED DOCUMENT.		DWN BSV 25OCT2005	TE TE Connectivity	
DIMENSIONS: mm [INCHES]		CHK BSV 25OCT2005		
TOLERANCES UNLESS OTHERWISE SPECIFIED:		APVD BSV 25OCT2005	NAME CONTACT, GOLD STRIPE, 20 AWG WIRE, LOOSE PIECE, MTA 156	
0 PLC ± -		PRODUCT SPEC	SIZE A3	
1 PLC ± -		APPLICATION SPEC	CAGE CODE 00779	DRAWING NO C=641144
2 PLC ± -		WEIGHT	RESTRICTED TO	
3 PLC ± 0.13 [.005]		CUSTOMER DRAWING	SCALE 8:1	SHEET 1 OF 1
4 PLC ± -			REV C2	
ANGLES ± -				
MATERIAL 0.30 [.012] THK COPPER ALLOY		FINISH SEE TABLE		