

THIS DRAWING IS UNPUBLISHED.

RELEASED FOR PUBLICATION

ALL RIGHTS RESERVED.

© COPYRIGHT - By -

LOC AF DIST 50

REVISIONS

P	LTR	DESCRIPTION	DATE	DWN	APVD
E		REVISED PER ECR-12-013518	24NOV12	KH	PD

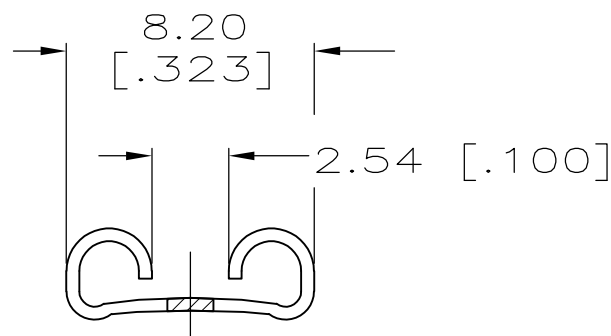
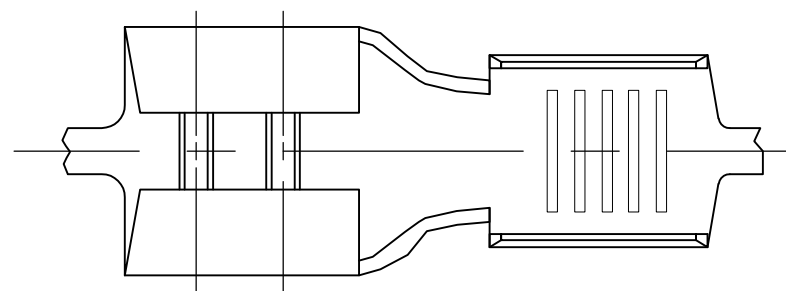

VIEW A-A

- 1 CONTINUOUS STRIP ON REELS.
 - 2 MATING TAB THK TO BE 0.813 ± 0.025 [$.032 \pm .001$]
 - 3 WIRE SIZE TO BE [#10-#8] AWG OR FOUR [#14 1/2] AWG.
 - 4 5 LBS MAX INSERTION/0.5 LBS MIN EXTRACTION. CHECK WITH TEST TAB NO. 60447-1 PER I.S. SHEET 7432.
- △5 0.00381 [.000150] MIN TIN OVER
0.00254 [.000100] MIN COPPER.

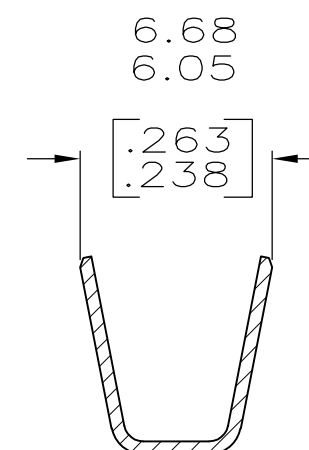
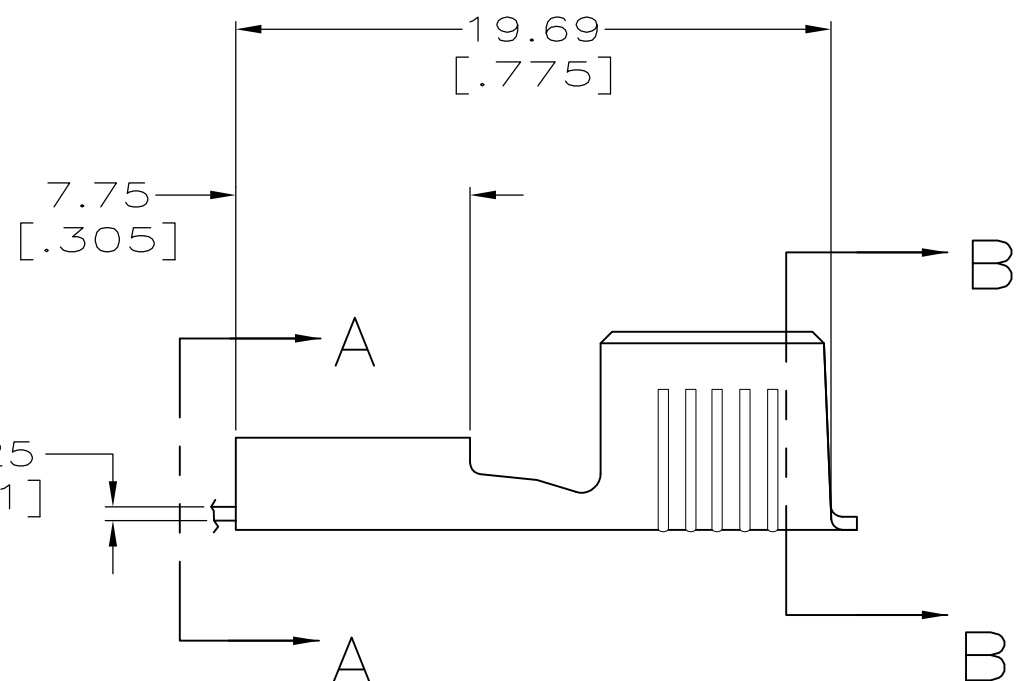

SECTION B-B

63902-1
PART NO.

THIS DRAWING IS A CONTROLLED DOCUMENT.		DWN JR RUTH 4/19/96	 TE Connectivity RECEPTACLE, FASTON, 6.98 [.275] SERIES					
DIMENSIONS: mm [INCHES]		CHK MS FEHER 4/19/96				NAME		
TOLERANCES UNLESS OTHERWISE SPECIFIED:		APVD P DESANTIS 4/19/96				PRODUCT SPEC		
0 PLC ± - 1 PLC ± - 2 PLC ± 0.25 [.010] 3 PLC ± - 4 PLC ± - ANGLES ± -		APPLICATION SPEC				RESTRICTED TO		
MATERIAL BRASS		FINISH △5	114-2036	SIZE A3	CAGE CODE 00779	DRAWING NO C-63902		
CUSTOMER DRAWING			WEIGHT -	SCALE 4:1	SHEET 1 OF 1	REV E		