

REVISIONS					
P	LTR	DESCRIPTION	DATE	DWN	APVD
B		REV PER EC 0K80-0079-00	12APR2000	JRB	GEM
B1		REV PER EC 0K80-0139-03	16MAY2003	DJA	SSA
B2		REV PER ECO-20-011283	13AUG2020	GTG	MT

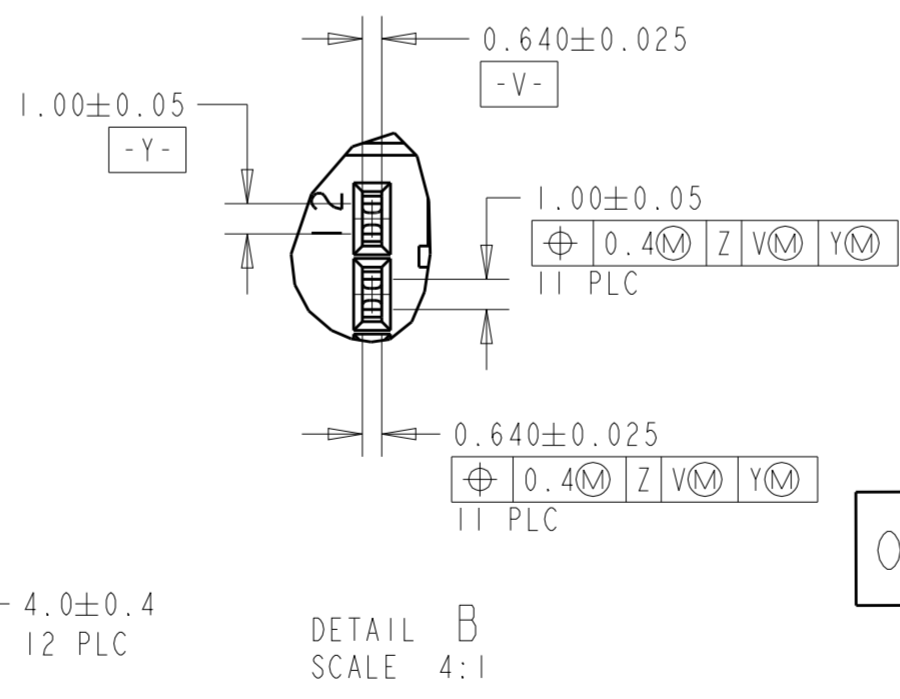
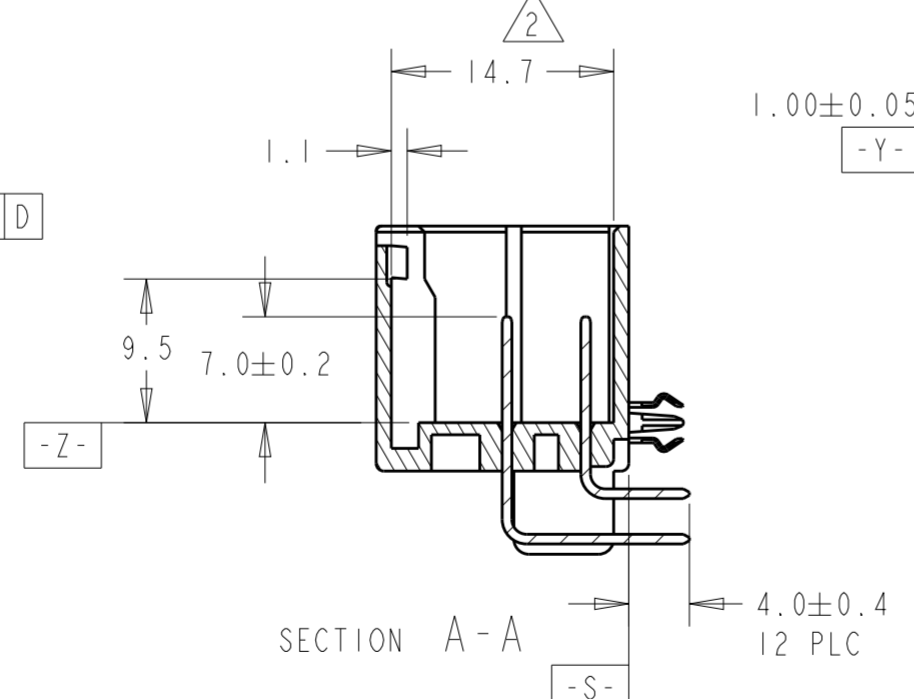
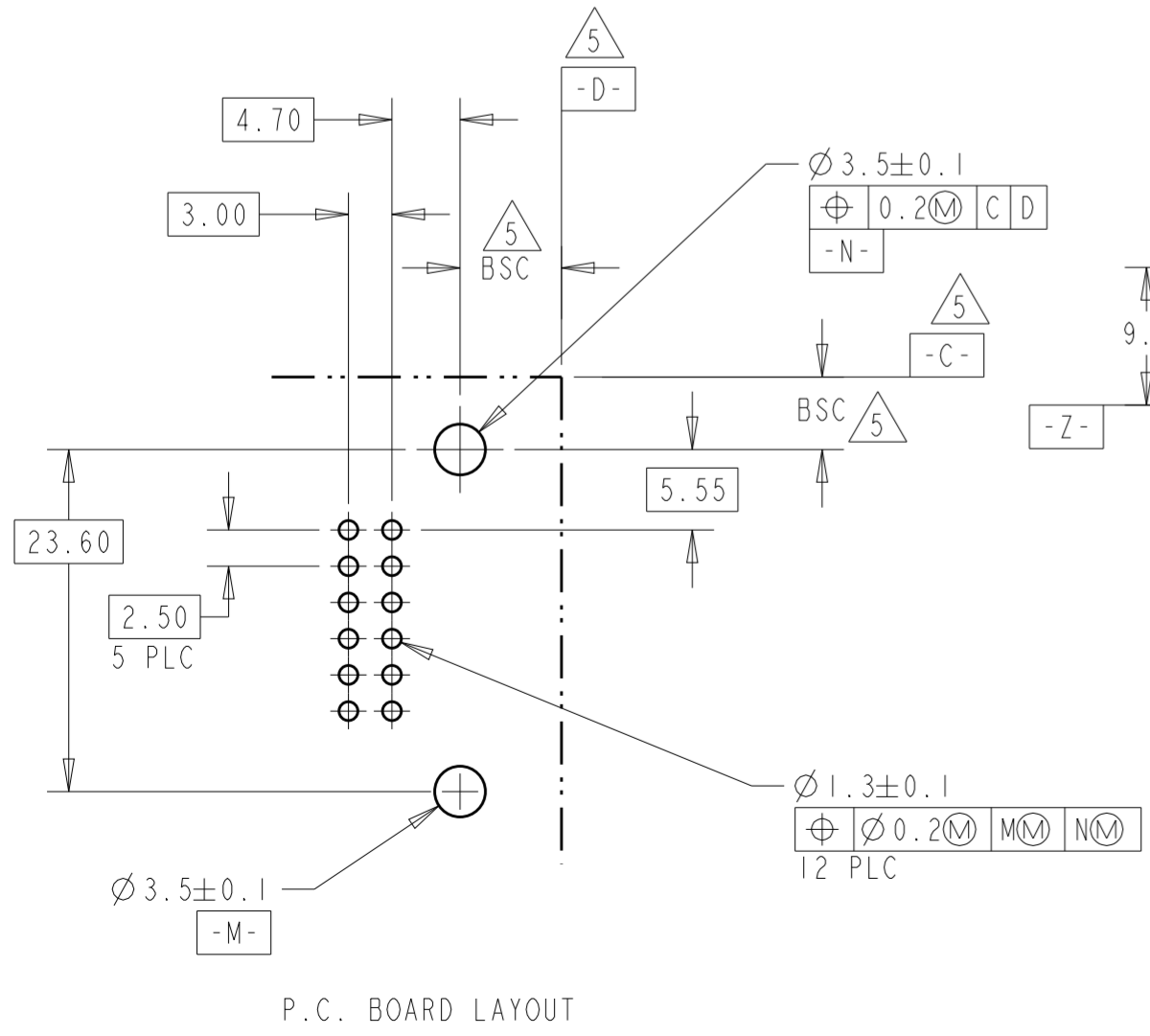
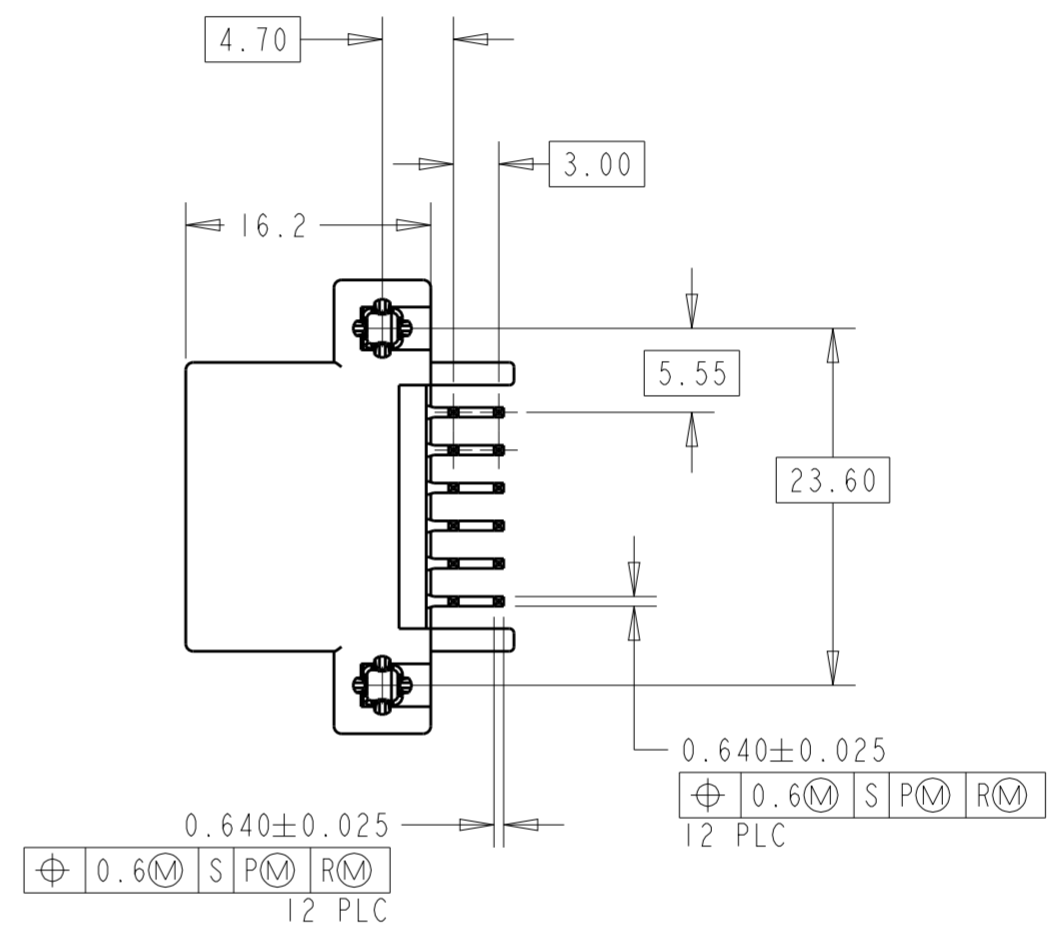
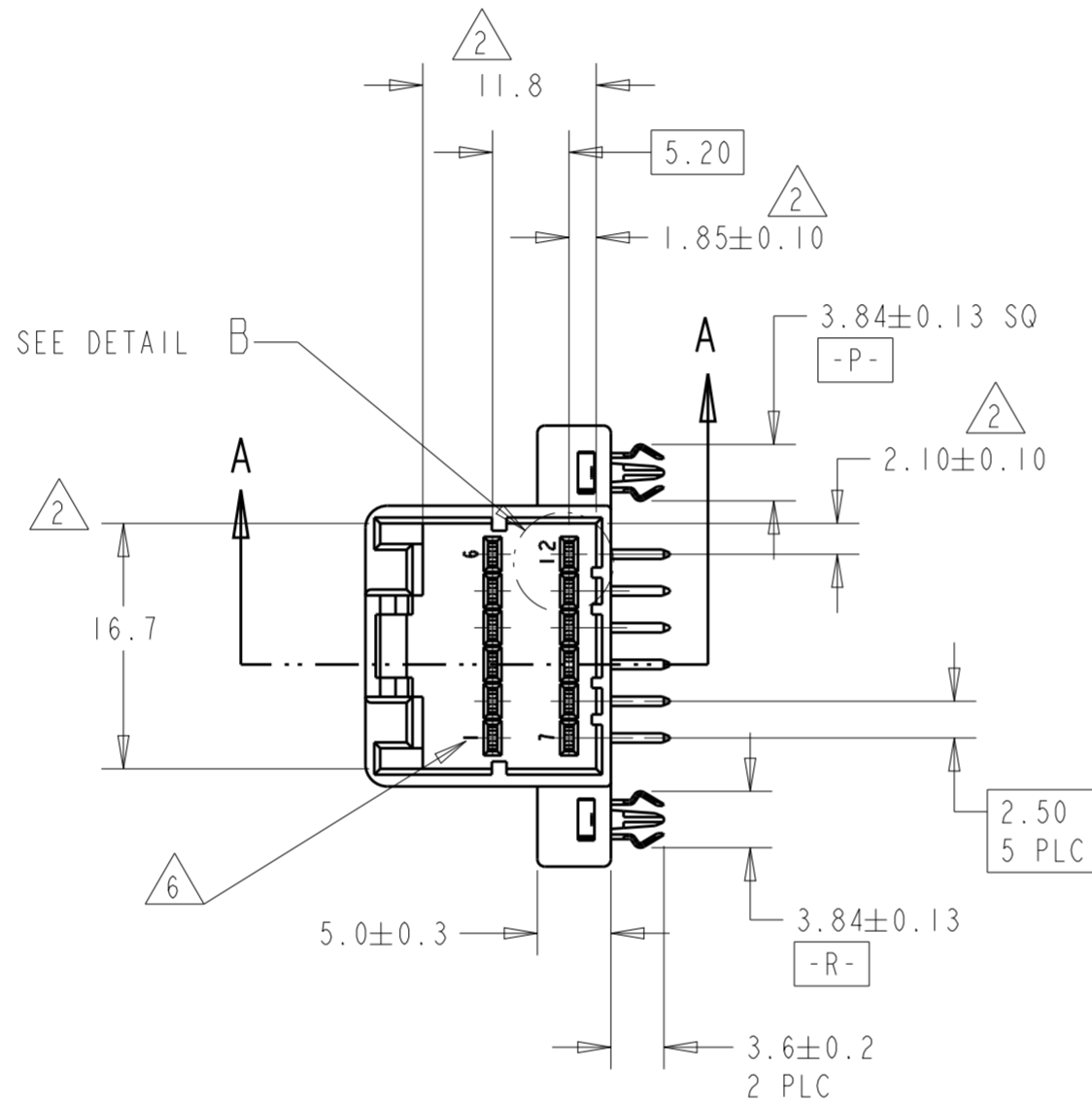
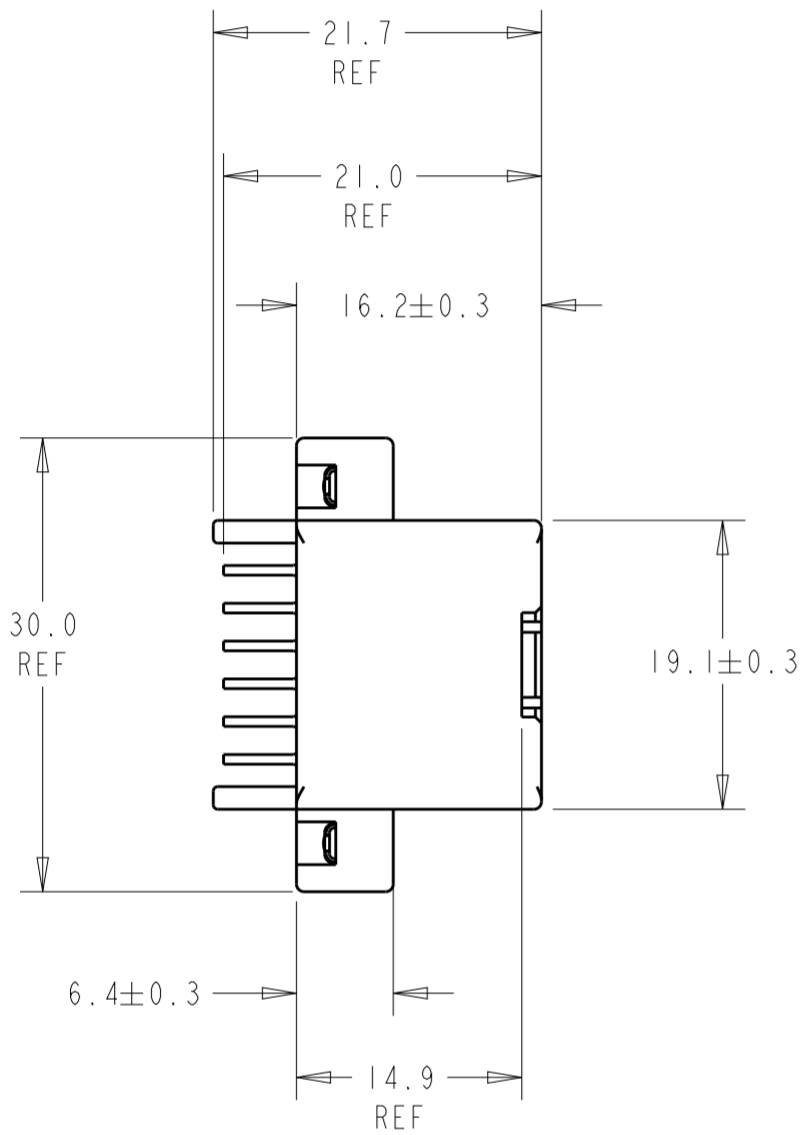
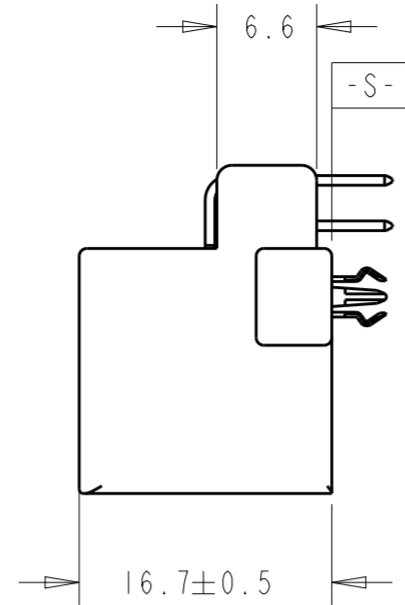
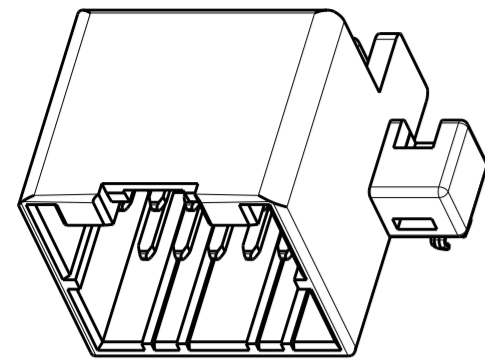

NOTE

1. APPLICABLE P.C. BOARD THICKNESS: 1.6mm
2. TO BE MEASURED BETWEEN -Z- AND 2mm FROM -Z-
3. NO CRACK PERMISSBLE
4. THE MATING PLUG HOUSING AMP PN 174045
5. DATUMS AND BASIC DIMENSIONS ESTABLISHED BY CUSTOMER.
6. CIRCUIT NUMBER

OBSOLETE	TIN OVER COPPER	POST TIN	BRASS	BLACK	PBT	9-638230-2
	TIN OVER COPPER	TIN OVER COPPER	BRASS	BLACK	PBT	638230-2
	BOARDLOCK FINISH	CONTACT FINISH	CONTACT MATERIAL	COLOR	HOUSING MATERIAL	PART NUMBER

THIS DRAWING IS A CONTROLLED DOCUMENT.		DWN Y. PETERSON 24FEB99	TE Connectivity		
DIMENSIONS: mm		CHK M. MENDYK 24FEB99			
TOLERANCES UNLESS OTHERWISE SPECIFIED:		APVD M. MENDYK 24FEB99	NAME ASSY, CAP, .040 12P		
0 PLC ±0.3		PRODUCT SPEC	108-5244		
1 PLC ±0.15		APPLICATION SPEC	-		
2 PLC ±		WEIGHT	-		
3 PLC ±		CUSTOMER DRAWING	SCALE 2/1 SHEET 1 OF 1 REV B2		
4 PLC ±					
ANGLES ±1					
FINISH					