

THIS DRAWING IS UNPUBLISHED. RELEASED FOR PUBLICATION .19  
 © COPYRIGHT 19 BY AMP INCORPORATED. ALL RIGHTS RESERVED.

LOC	DIST	REVISIONS					
		P	LTR	DESCRIPTION	DATE	DWN	APVD
FX	00		0	RELEASED	09MAR2000	JRB	CBP

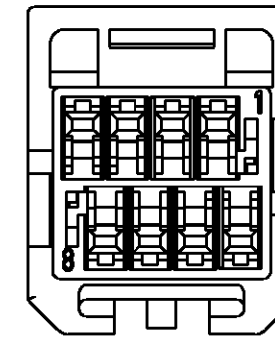

- 1 DATE CODE TO BE PERMANENTLY APPLIED APPROX IN AREA SHOWN.
- 2 TPA TO BE LATCHED POSITIVELY TO THE HOUSING IN THE STAGED POSITION AS SHOWN.

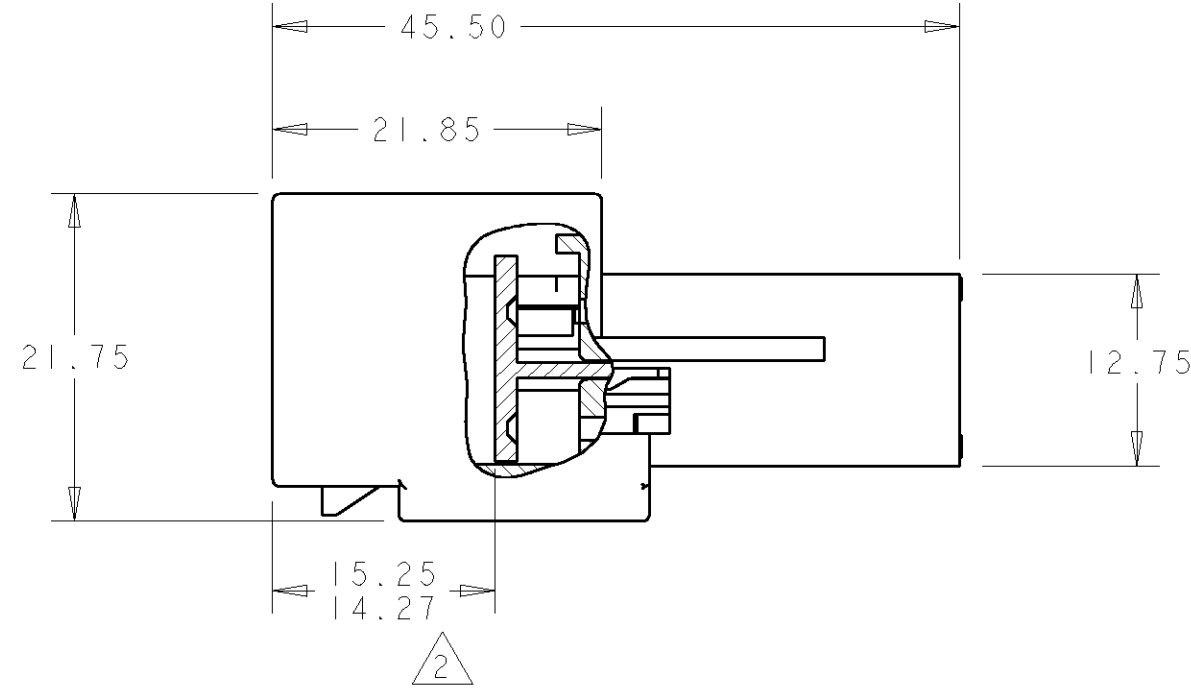
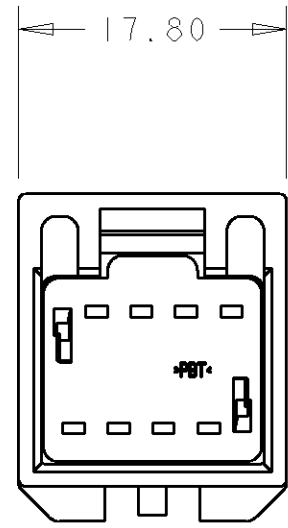
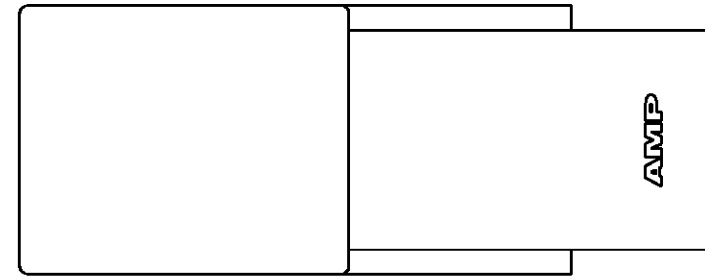
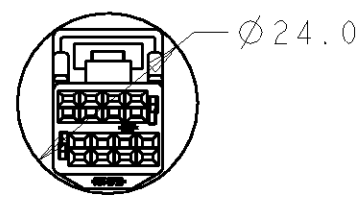
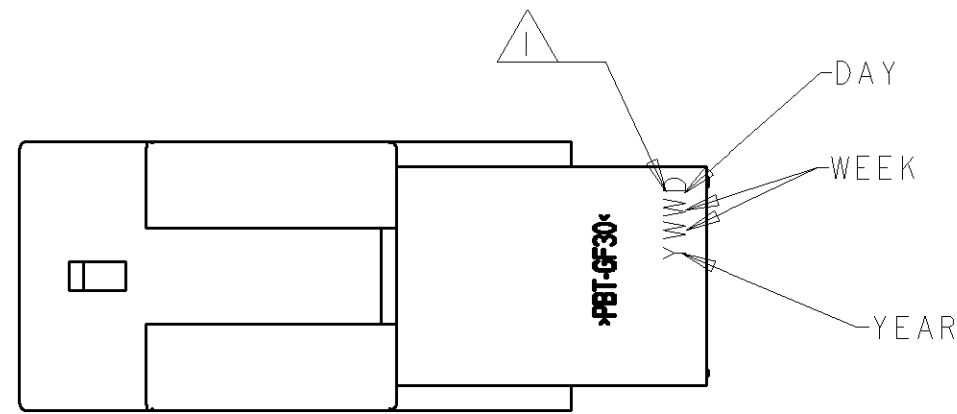

SCALE 1:1

<small>THIS DRAWING IS A CONTROLLED DOCUMENT FOR AMP INCORPORATED. IT IS SUBJECT TO CHANGE AND THE CONTROLLING ENGINEERING ORGANIZATION SHOULD BE CONTACTED FOR THE LATEST REVISION.</small>		DWN J BUSSARD 09MAR00 CHK CB PAUL 09MAR2000 APVD CB PAUL 09MAR2000	<b>AMP</b> AMP Incorporated Harrisburg, PA 17105-3608
DIMENSIONS: mm	TOLERANCES UNLESS OTHERWISE SPECIFIED: 0 PLC ±-- 1 PLC ±0.3 2 PLC ±0.10 3 PLC ±-- 4 PLC ±-- ANGLES ±1.0° FINISH -	PRODUCT SPEC - APPLICATION SPEC - WEIGHT -	NAME 8 POSITION CAP ASSEMBLY WIRE TO WIRE CONNECTOR SIZE A2 CAGE CODE 00779 DRAWING NO. 638151
MATERIAL -		CUSTOMER DRAWING	SCALE 2:1 SHEET 1 OF 1 REV 0