

LOC		DIST		REVISIONS			
AF	50	REV	DATE	BY	APPV	DATE	DESCRIPTION
		K	09SEP14	PKS	RRP		FINISH INFO UPDATED

- 1 CONTINUOUS STRIP ON REELS WITH TERMINALS LOCATED ON 12.7±0.08 [.500±.003] CENTERS.
- △2 SLOT TERMINATES EITHER A SINGLE OR DOUBLE MAGNET WIRES TO THE SAME TYPE AND SIZE, COPPER RANGE: 0.23-0.32mm [#31-#28] AWG.
- △3 BOX TO MEET THIS DIMENSION WHEN INSERTED INTO A CAVITY 3.12 [.123] DEEP.
- △4 SYMMETRY TO BE MEASURED AT THE "NOSE" OF THE BOX.
- △5 MEASURE PLATING THICKNESS ON THE TAB; FORMED SIDE OF THE TERMINAL.
- △6 SLOT MUST ACCEPTS AN 0.122 [.0048] DIA PIN GAGE; SLOT MUST NOT ACCEPT AN 0.20 [.008] DIA PIN GAGE. MEASURE ONE BEAM AT A TIME.
- △7 TIN PLATED OVER NICKEL PER QQ-N-290.
- △8 POINT OF MEASUREMENT, LOCATED APPROXIMATELY AS SHOWN
- △9 NO BURRS PERMITTED ON TIP OF TAB.

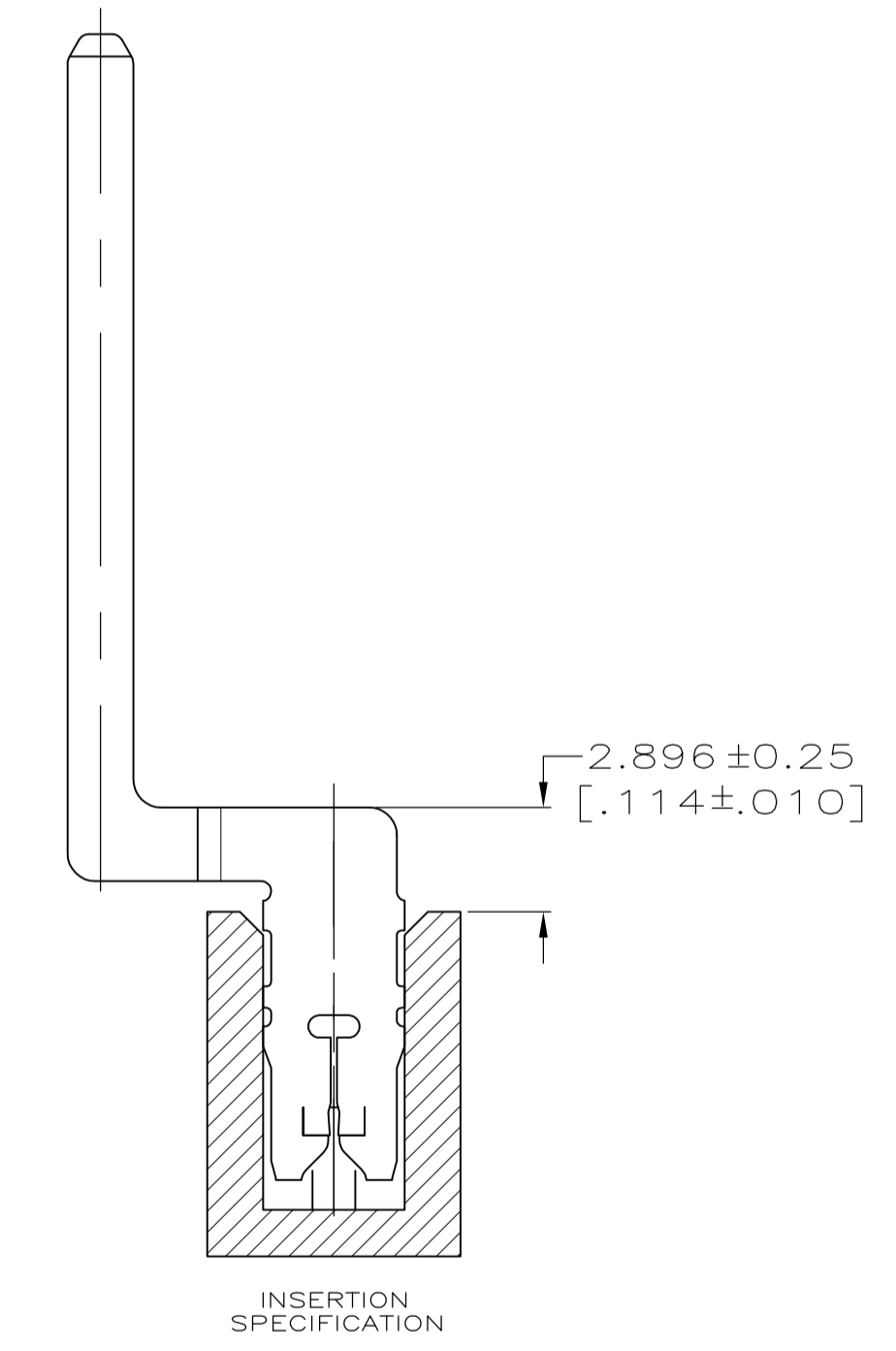
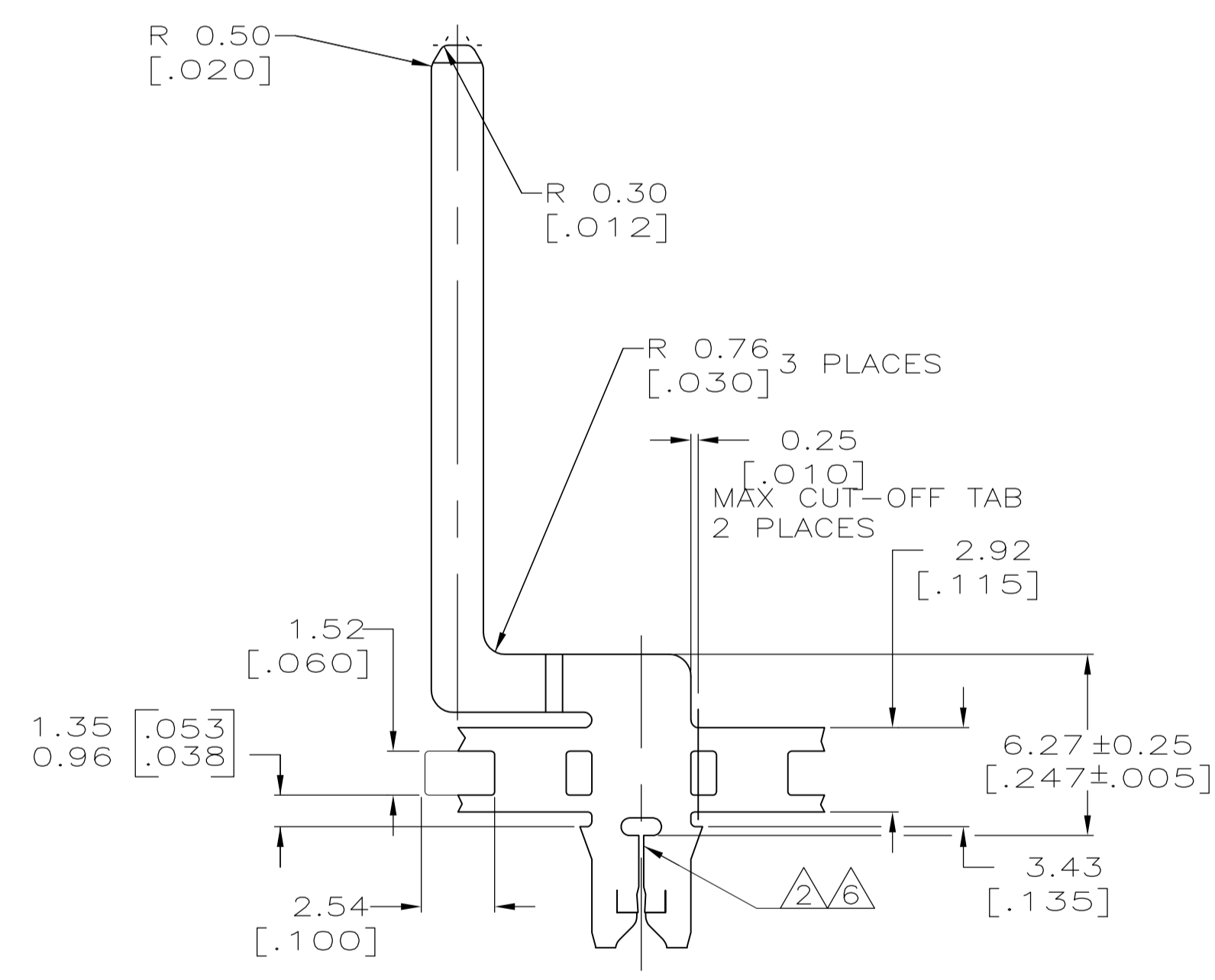
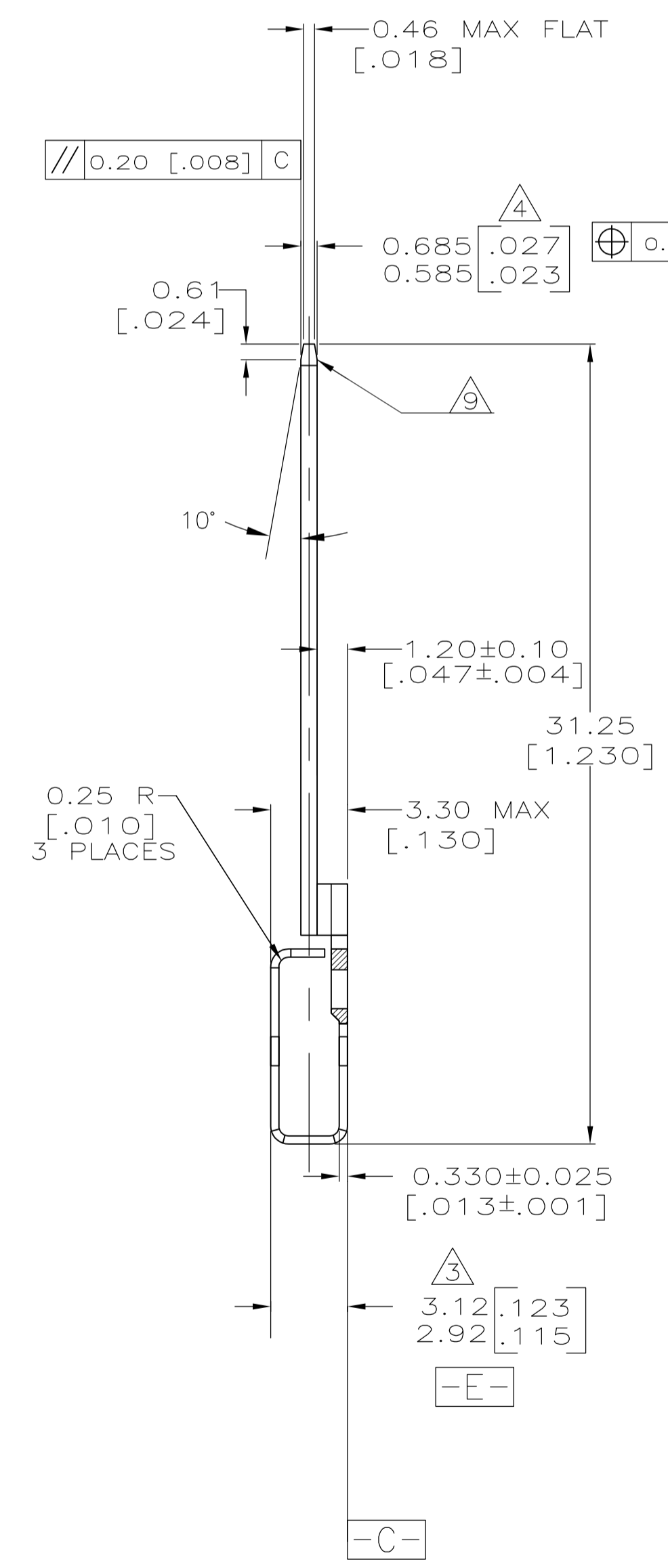
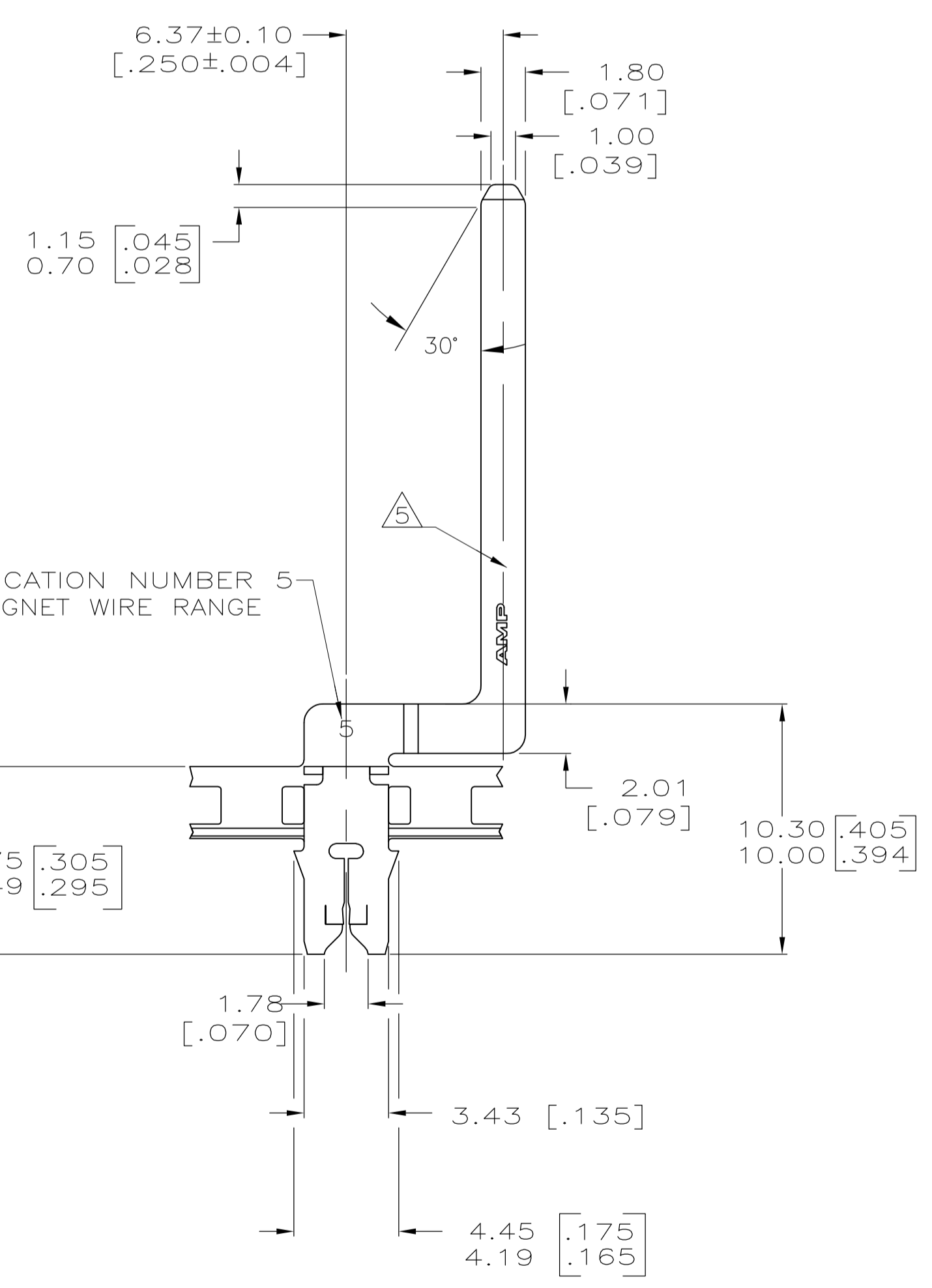
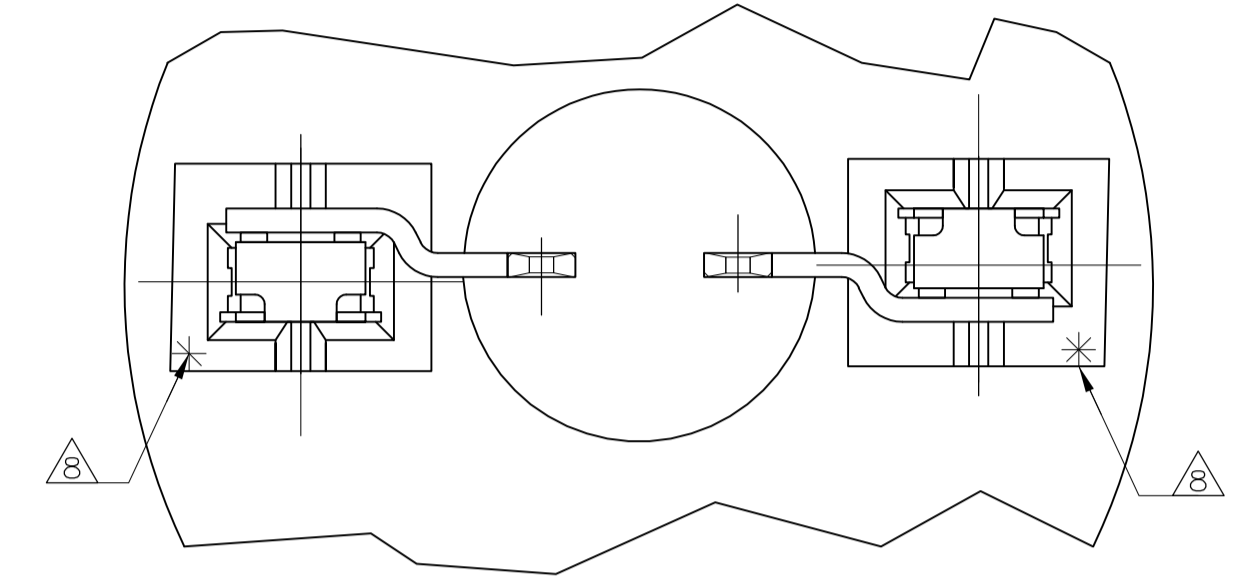
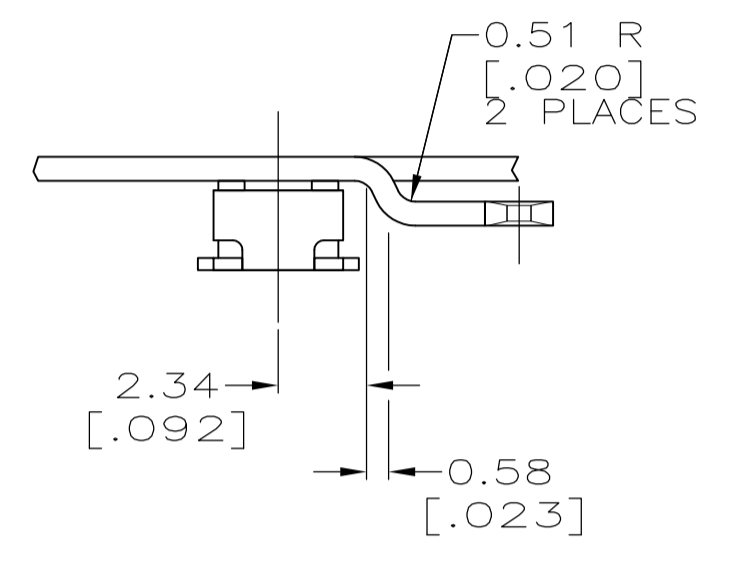

63773-1
PART NO.

THIS DRAWING IS A CONTROLLED DOCUMENT.		DIN R GRZYBOWSKI 09NOV95		APVD M.S.FEHER 09NOV95		NAME TL SHUTTER 09NOV95		SIZE A1		SCALE 5:1		SHEET 1 OF 1		REV K	
DIMENSIONS: MM [INCHES]		TOLERANCES UNLESS OTHERWISE SPECIFIED:		0. PLC ± -		1. PLC ± -		2. PLC ± ± 0.15[.006]		3. PLC ± ± -		4. PLC ANGLES ± ± -		MATERIAL BRASS	
FINISH		-E-		-C-		-E-		-C-		CUSTOMER DRAWING		WEIGHT		RESTRICTED TO	
APPROVALS		DRAWING NO 108-2012		APPLICATION SPEC 114-2046		DRAWING NO 63773		CUSTOMER DRAWING		SCALE 5:1		SHEET 1 OF 1		REV K	