

LOC	DIST	REVISIONS					
AP	-	P	LTR	DESCRIPTION	DATE	DWN	APVD
			H	REVISED DRAWING ECO-11-000075	05JAN2011	NCL	ASV
			J	REVISED DRAWING ECO-15-015834	04NOV2015	NCL	DAO

creo
Creo Parametric 2.0
**DO NOT REVISE
EXCEPT BY CAD**

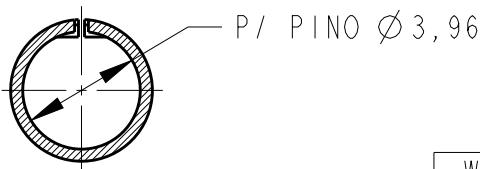
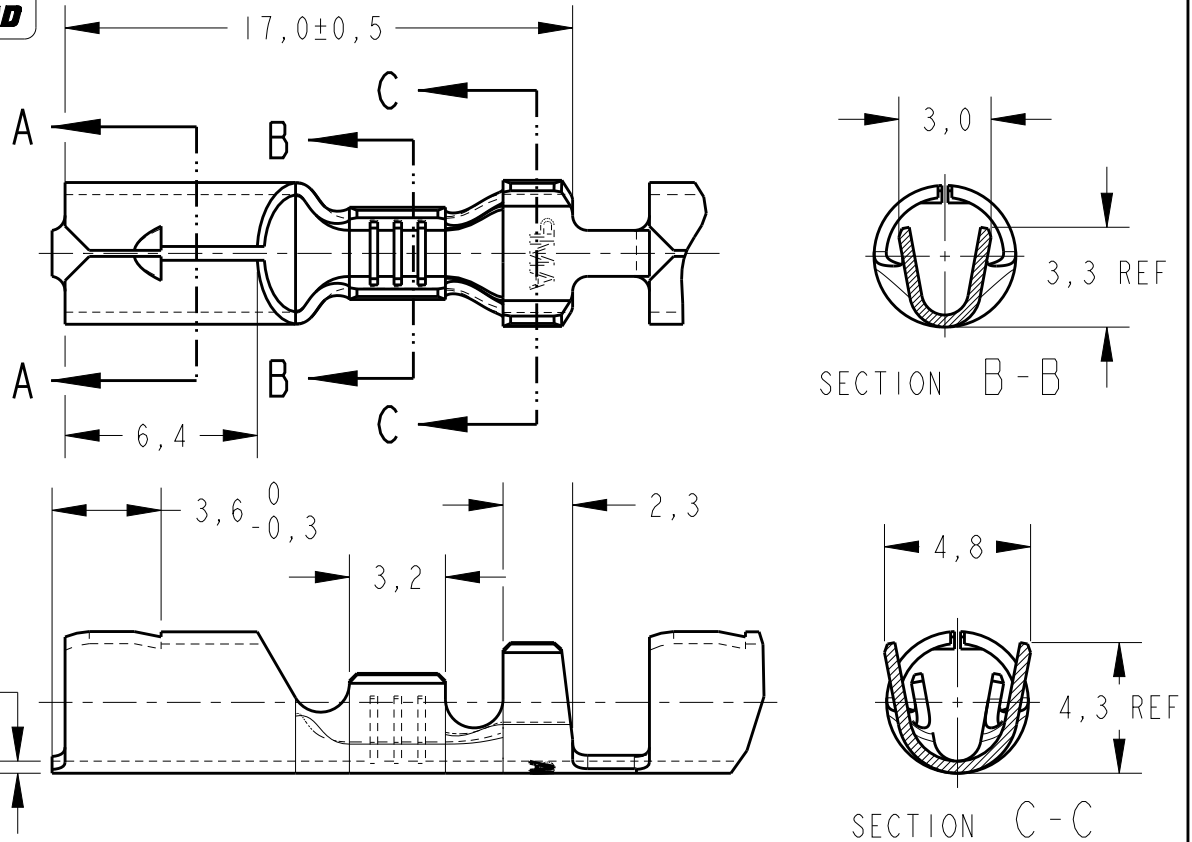

- OBSOLETE PARTS: OBSOLETE CIS STREAMLINING PER D.RENAUD/D.SINISI

WIRE RANGE	INS. RANGE
20-16 AWG	2,3-3,3mm ²

626 564-5	PRATEADO	BRONZE FOSF.	626 400-5
626 564-4	PRATEADO	LATÃO	626 400-4
626 564-3	—	BRONZE FOSF.	626 400-3
626 564-2	ESTANHADO	LATÃO	626 400-2
626 564-1	—	LATÃO	626 400-1
LOOSE PIECE	FINISH	MATERIAL	PART NUMBER

DIMENSIONS: mm	DWN R.K.S.T.LEME 13JUN2007	MATERIAL SEE TABLE	FINISH SEE TABLE
TOLERANCES UNLESS OTHERWISE SPECIFIED:	CHK -/-	TE Connectivity	
0 PLC ±-	APVD S.H.OLIVEIRA -/-		
1 PLC ±0,4	PRODUCT SPEC -	NAME -	
2 PLC ±-	APPLICATION SPEC -	.156 DIA. SHUR PLUG REC.	
3 PLC ±-	WEIGHT -	SIZE A4	CAGE CODE 00779
4 PLC ±-		DRAWING NO C=626400	RESTRICTED TO -
ANGLES ±1°	Customer Drawing	SCALE 4:1	SHEET 1 OF 1
			REV J