

SPECIFICATIONS

ELECTRICAL

RESISTANCE: 5KΩ ±10%
 ELECTRICAL ANGLE: 340° ±1°
 CONTINUITY ANGLE: 352°MIN
 LINEARITY: ±0.5%, INDEPENDENT
 MINIMUM VOLTAGE: 0.1% MAX
 RESOLUTION: VIRTUALLY INFINITE
 OUTPUT SMOOTHNESS: 0.1% MAX
 RESISTANCE TEMPERATURE COEFFICIENT: ±400 PPM/°C MAX
 POWER RATING: 1.5 WATT MAX @ 70°C,
 DERATED TO 0.0 WATT @ 125°C
 WIPER CONTACT CURRENT: 10 MILLIAMPS MAX
 DIELECTRIC STRENGTH: 1,000 VRMS @ 60 Hz
 INSULATION RESISTANCE: 100 MEG OHMS @ 500 VDC

MECHANICAL

ROTATION: CONTINUOUS 360°
 WEIGHT: (1 GANG) 2.0 OZ MAX
 MECH BACKLASH: <0.1°
 START TORQUE: 0.3 OZ-IN MAX
 RUNNING TORQUE: 0.2 OZ-IN MAX
 PILOT RUNOUT: 0.001 T.I.R.
 SHAFT RUNOUT: 0.001 T.I.R.
 SHAFT END PLAY: 0.003 MAX
 SHAFT RADIAL PLAY: 0.001 T.I.R.
 LATERAL RUNOUT: 0.002 T.I.R.

ENVIRONMENTAL

OPERATING TEMPERATURE: -65°C TO +125°C
 ROTATIONAL LIFE: 50 MILLION CYCLES MIN
 DITHER LIFE: 50 MILLION CYCLES @ 60HZ OVER 5°
 SHOCK: SAWTOOTH 100G PEAK PER MIL-STD-202
 METHOD 213, TEST CONDITION I
 VIBRATION: HIGH FREQ; SWEPT 10 - 2000HZ, 15G
 PEAK

PER MIL-STD-202 TEST CONDITION B

MATERIALS

HOUSING AND COVER: ANODIZED ALUMINUM
 SHAFT: PASSIVATED STAINLESS STEEL
 BEARINGS: PRECISION MINIATURE BALL
 ROTOR: BERYLLIUM COPPER
 CONTACTS: MULTI-FINGER PRECIOUS METAL
 ELEMENT: CO-MOLDED CONDUCTIVE PLASTIC
 TERMINALS: GOLD PLATED BRASS

UNLESS OTHERWISE SPECIFIED

ALL ELECTRICAL, MECHANICAL, AND ENVIRONMENTAL SPECIFICATIONS ARE IAW MIL-PRF-39023

CUSTOMER:	CATALOG
CUSTOMER DWG/REV:	N/A

CHANGE HISTORY				
REV	DESCRIPTION	DATE	DRAWN	APPROVED
A	RELEASE	10/7/92	--	DARB
B0	ECN 5134	11/20/14	JDD	BD
B1	ECN 6167	7/17/17	JDD	PDC

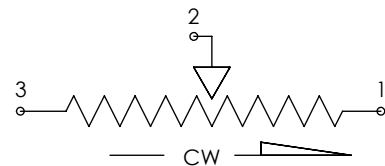
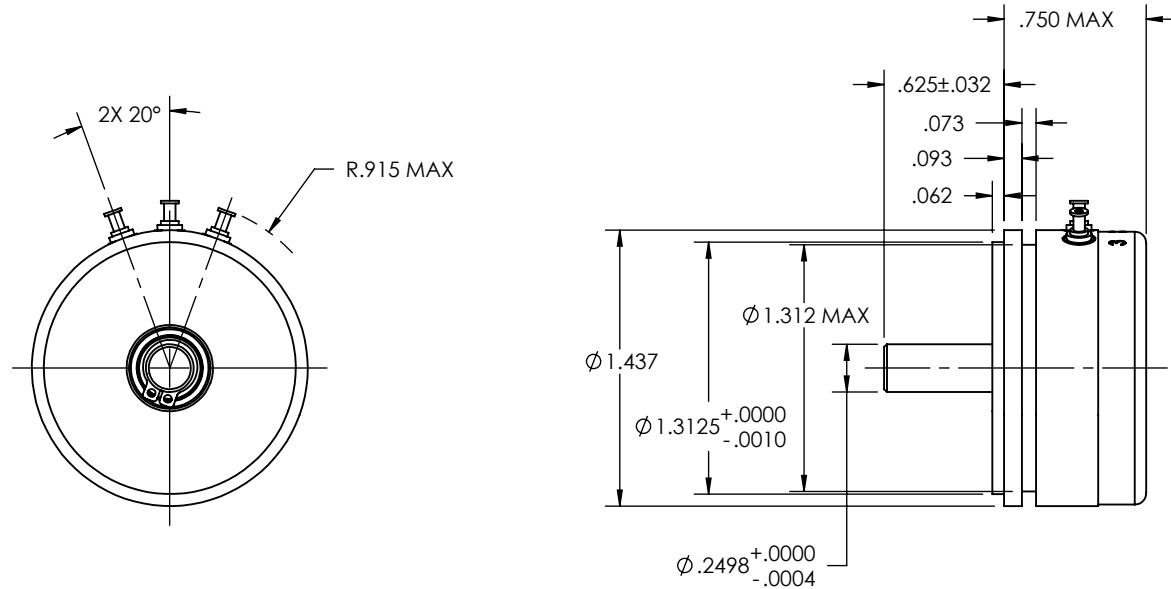
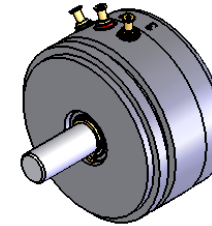

INCREASING FUNCTION VIEWED FROM SHAFT END

<p>PROPRIETARY AND CONFIDENTIAL</p> <p>THE INFORMATION CONTAINED IN THIS DRAWING IS THE SOLE PROPERTY OF TE CONNECTIVITY. ANY REPRODUCTION IN PART OR AS A WHOLE WITHOUT THE WRITTEN PERMISSION OF TE CONNECTIVITY IS STRICTLY PROHIBITED.</p>	<p>EAR CONTROL</p> <p>TECHNICAL INFORMATION SUBJECT TO EXPORT ADMINISTRATION REGULATIONS (EAR). THIS TECHNICAL INFORMATION IS PROHIBITED FROM TRANSFER OR DISCLOSURE IN ANY MANNER TO NON-U.S. PERSONS IN THE UNITED STATES OR ABROAD WITHOUT PRIOR APPROVAL BY THE U.S. COMMERCE DEPARTMENT OR APPLICABLE EAR EXEMPTION.</p>		NAME	DATE	
	DRAWN	D. TREE	10/7/1992		
	CHECKED				
	ENG APPR.				
			MFG APPR.		
			Q.A.		
<p>DIMENSIONS ARE IN INCHES</p> <p>TOLERANCES:</p> <p>ANGULAR ±2°</p> <p>TWO PLACE DECIMAL ±.01</p> <p>THREE PLACE DECIMAL ±.005</p> <p>FOUR PLACE DECIMAL ±.0005</p>	<p>MATERIAL</p> <p>NOTED</p>	<p>FINISH</p> <p>NOTED</p>	<p>Information in this box is for Engineering Reference Only</p>		
<p>DO NOT SCALE DRAWING</p>				<p>POTENTIOMETER</p>	
		CAGE CODE	DWG. NO.		
		5W885	6015-1002-030		
SHEET 1 OF 1					