

ONE INCH AND TWO INCH PART NUMBER BREAKDOWN

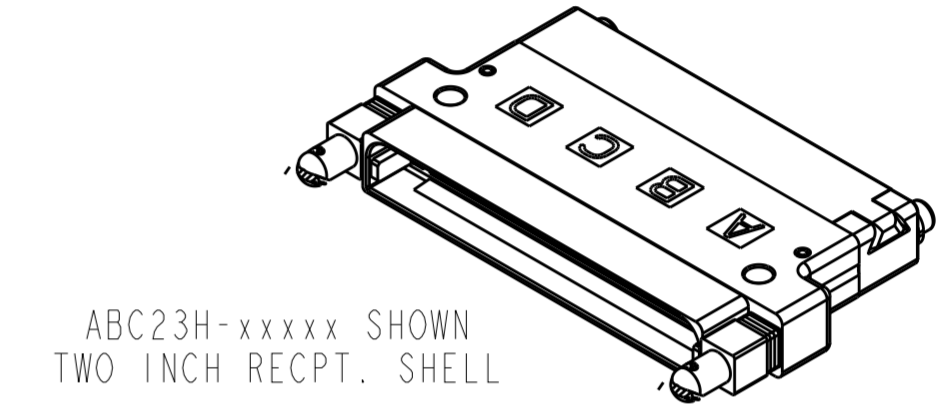

HALF INCH, IN-LINE PART NUMBER BREAKDOWN

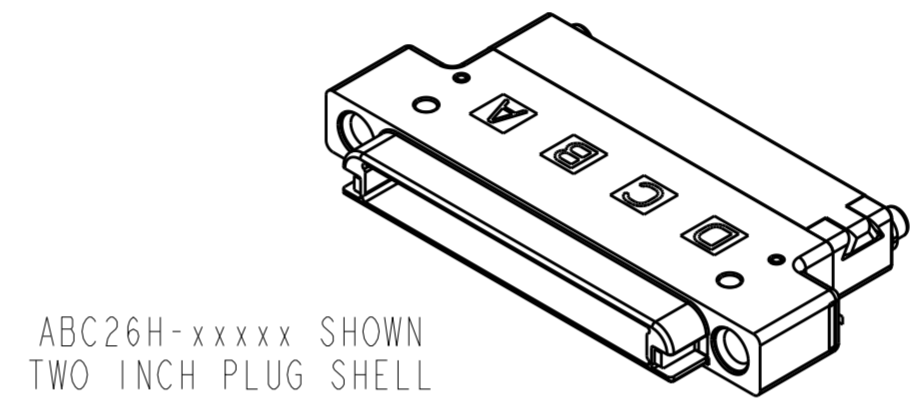
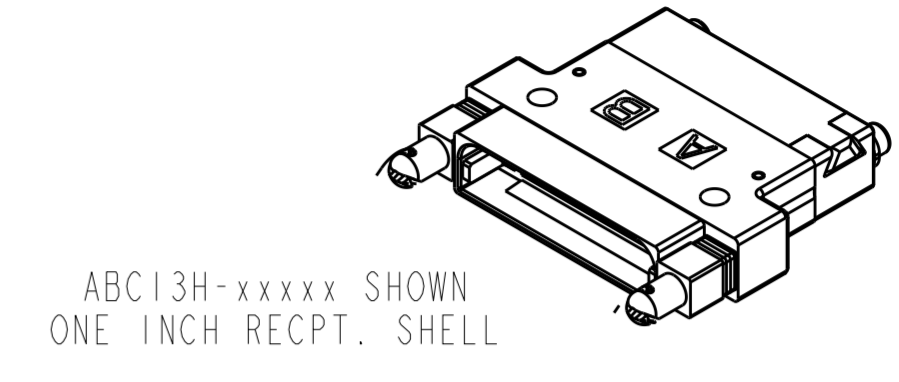
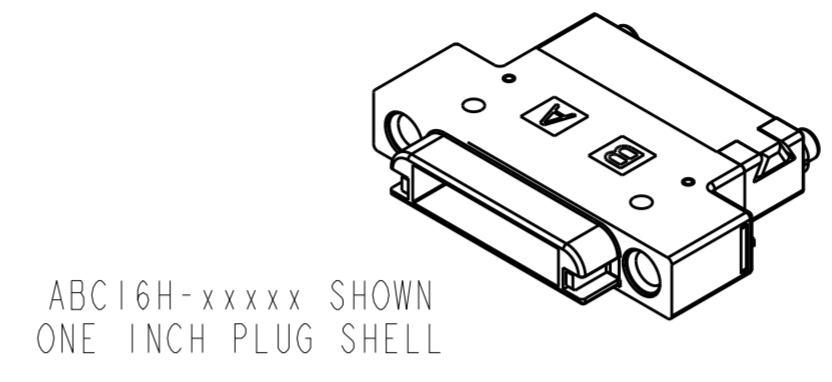
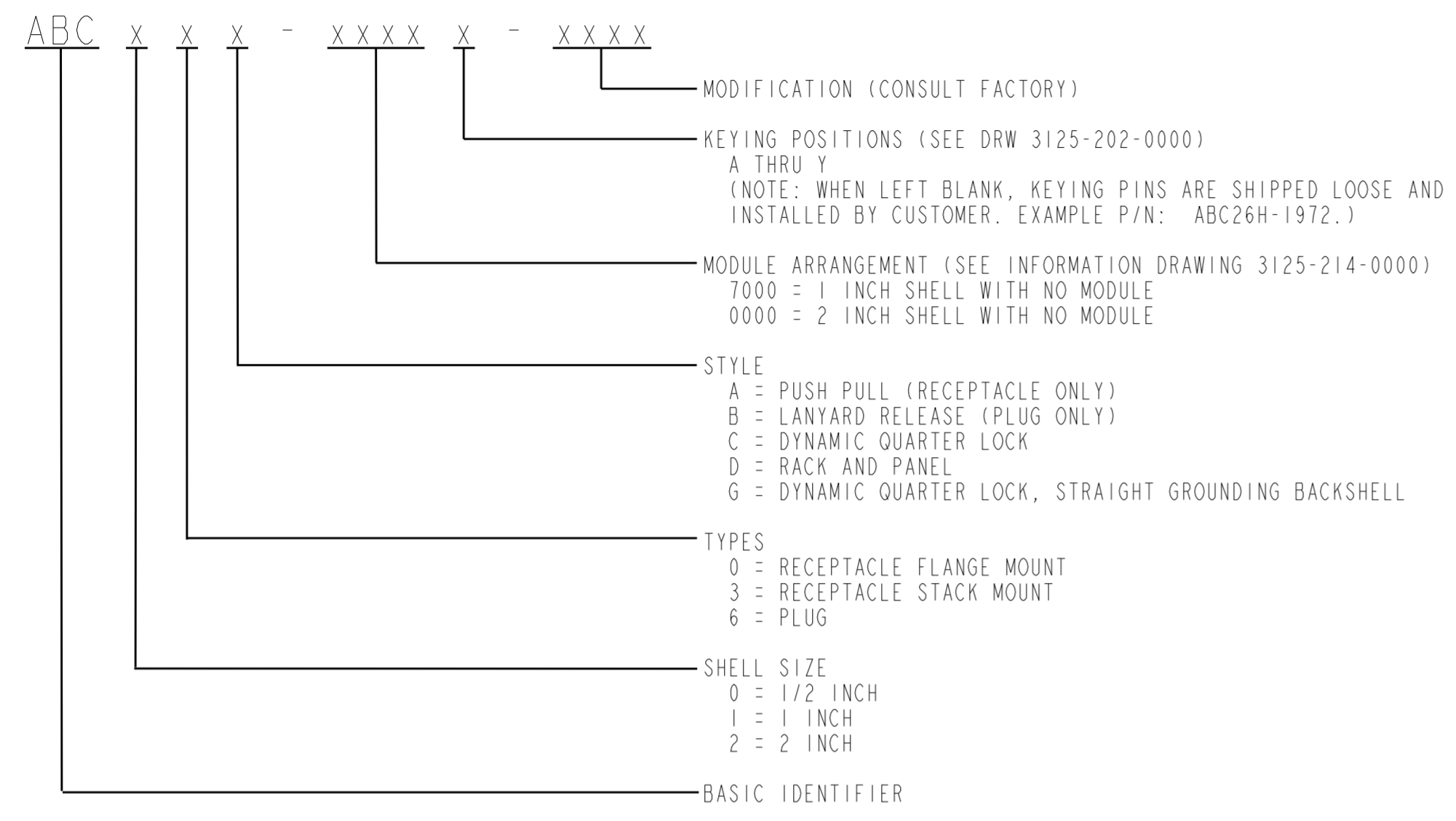
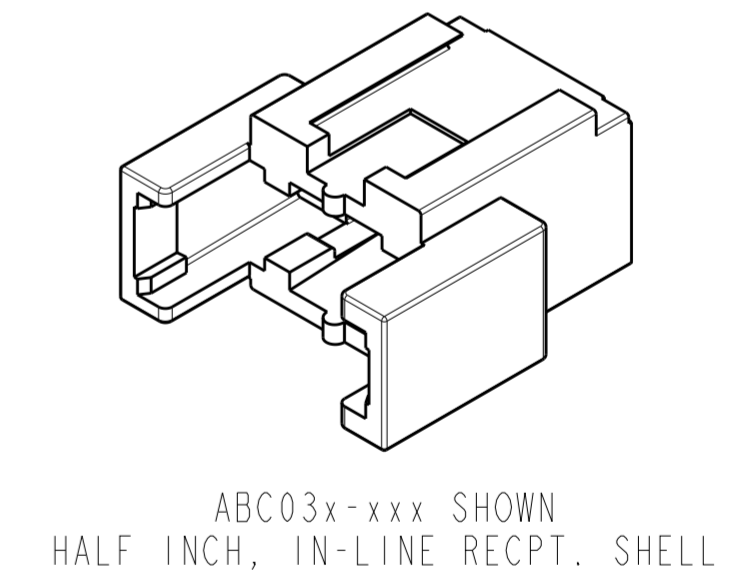
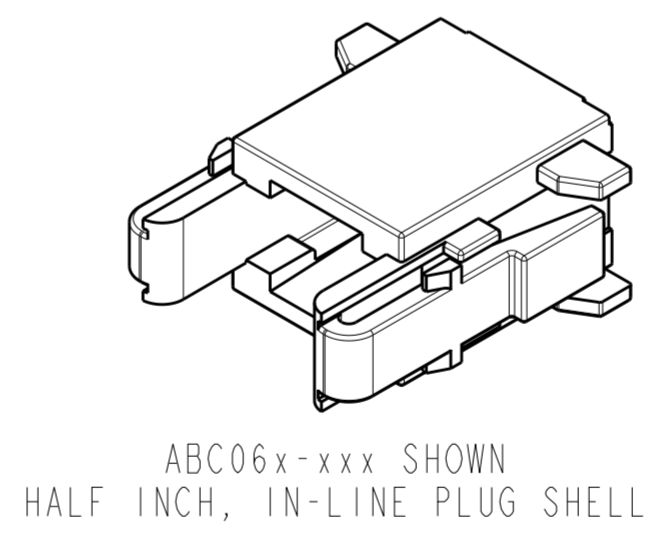
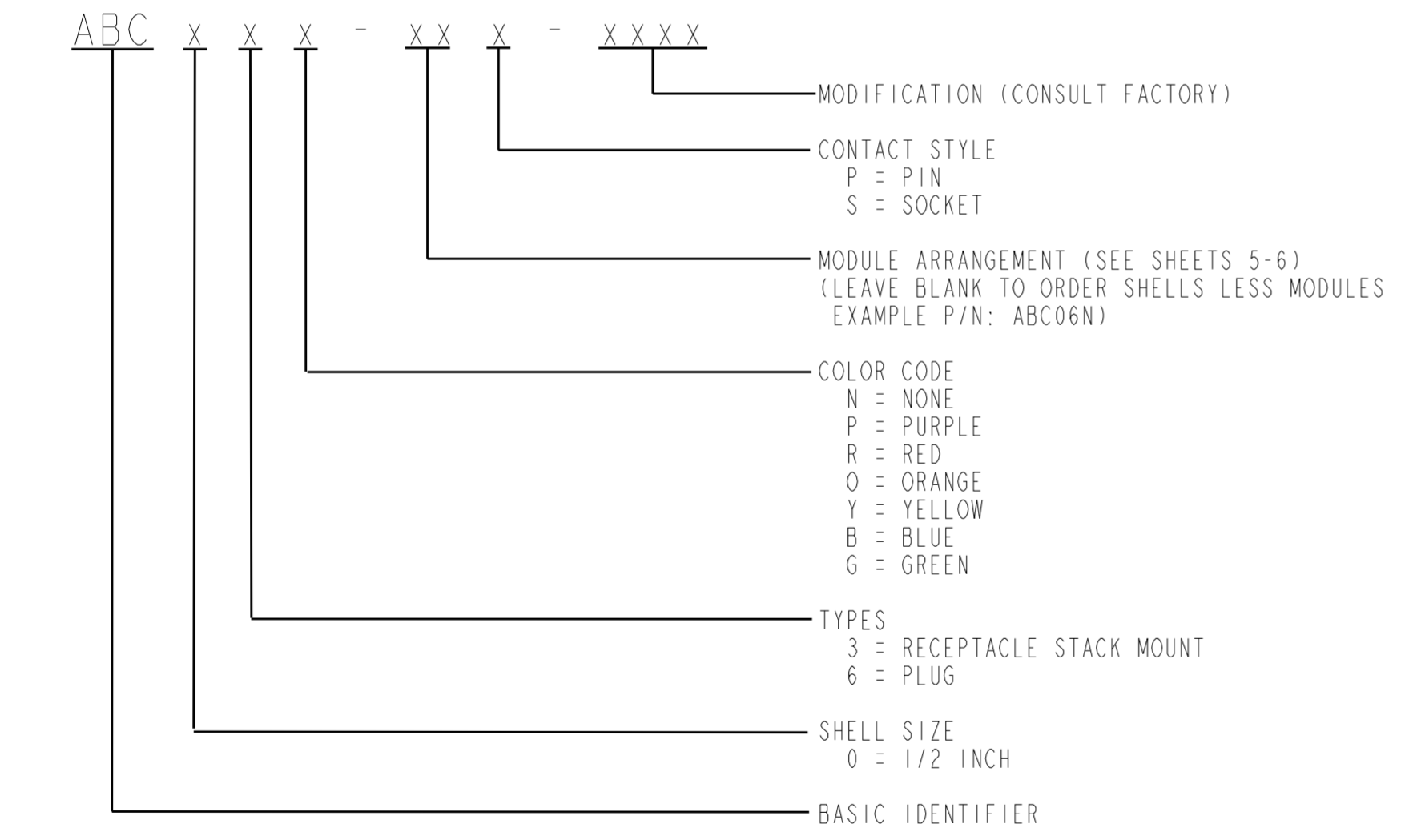

REVISIONS					
P	LTR	DESCRIPTION	DATE	DWN	APVD
G		REVISED PER E.O. C8352	110908	-	AR
H		REVISED PER ECO 14-008596	140519	EV	MA
J		REVISED PER ECR 15-005242	150424	MA	AR

NOTES: UNLESS OTHERWISE SPECIFIED

- FOR AVAILABILITY CONSULT FACTORY
- FOR PERFORMANCE REQUIREMENTS SEE TEC 108-32084

MC: 31	FINISH: SEE NOTES
DESCRIPTION: HALF, ONE, AND TWO INCH CONNECTOR PART NUMBER BREAKDOWN	
CAGE CODE: 11139	

THIS DRAWING IS A CONTROLLED DOCUMENT.		DWN M. ALI 141231	TE Connectivity				
DIMENSIONS: INCHES		CHK D. PASCUA 150424					
TOLERANCES UNLESS OTHERWISE SPECIFIED: 0 PLC ± 1 PLC ±0.1 2 PLC ±0.01 3 PLC ±0.001 4 PLC ±0.0001 ANGLES ± FINISH		APVD AR 150424	NAME ABC INFORMATION DRAWING HALF, ONE, AND TWO INCH CONNTRS AND MODULE CONFIGURATIONS	SIZE A2	CAGE CODE -	DRAWING NO. TEC 108-32084	RESTRICTED TO -
MATERIAL SEE NOTES		PRODUCT SPEC TEC 108-32084	SCALE 1.000	SHEET 1	OF 6	REV J	Customer Drawing

THIS DRAWING IS UNPUBLISHED. RELEASED FOR PUBLICATION 20
 © COPYRIGHT 20 BY - ALL RIGHTS RESERVED.

REVISIONS				
P	LTR	DESCRIPTION	DATE	APVD
-	-	SEE SHEET 1	-	-

ONE INCH PLUG
ABC16H-xxxxx

TWO INCH PLUG
ABC26H-xxxxx

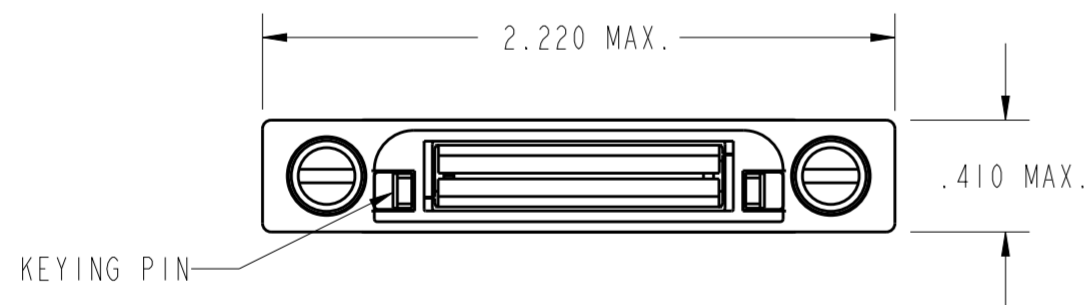
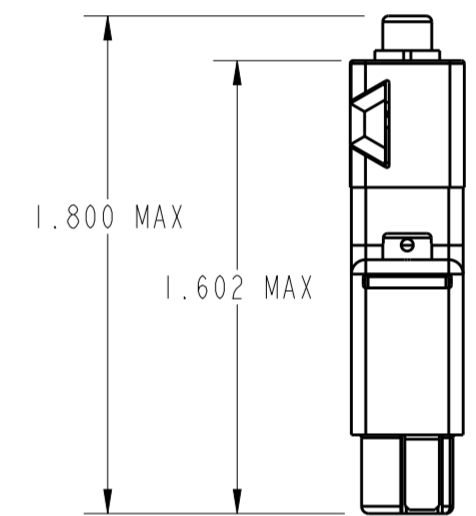
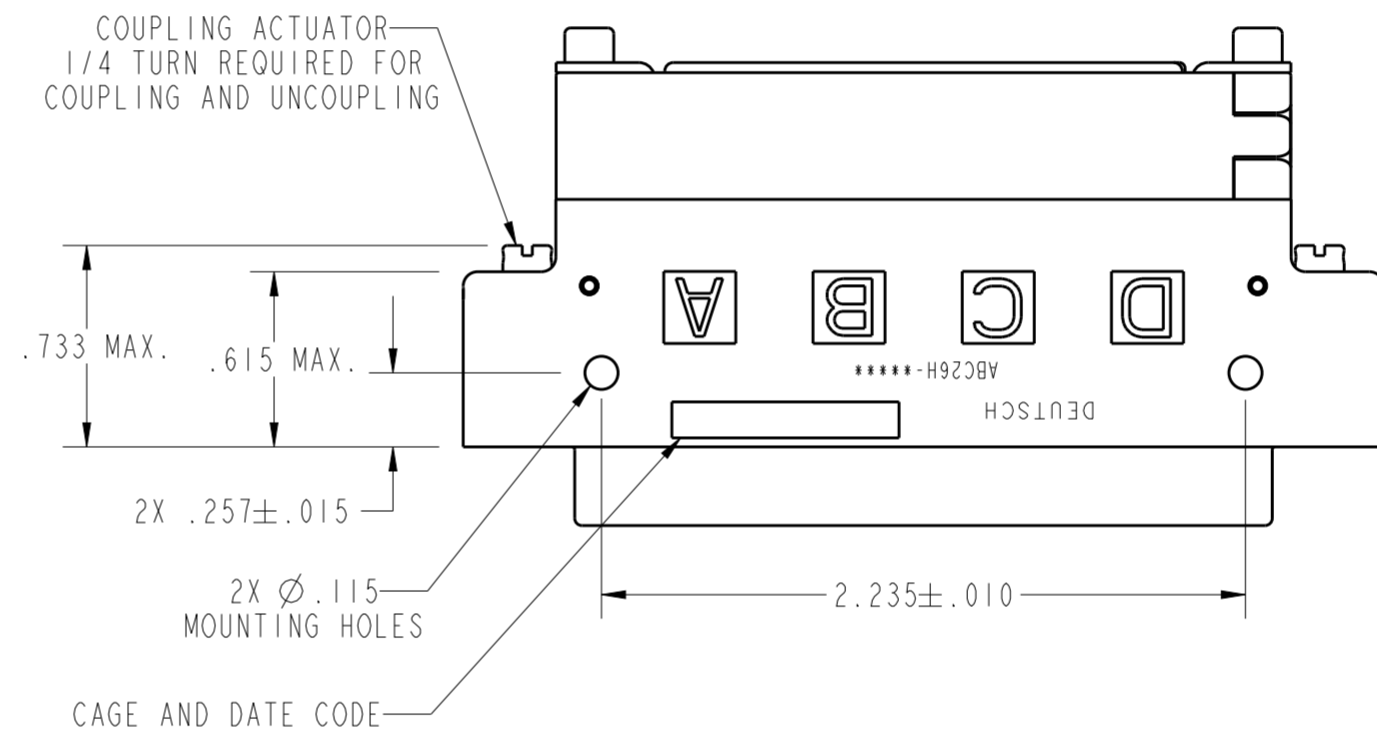
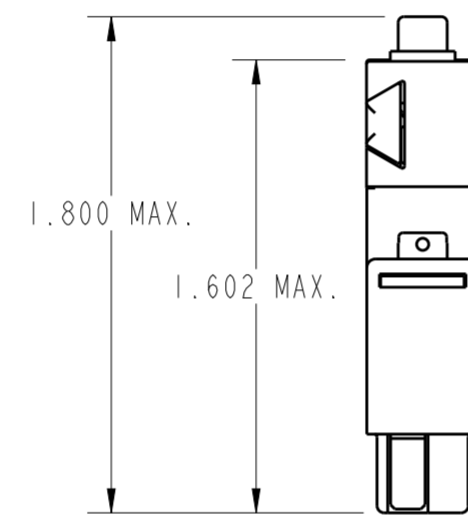
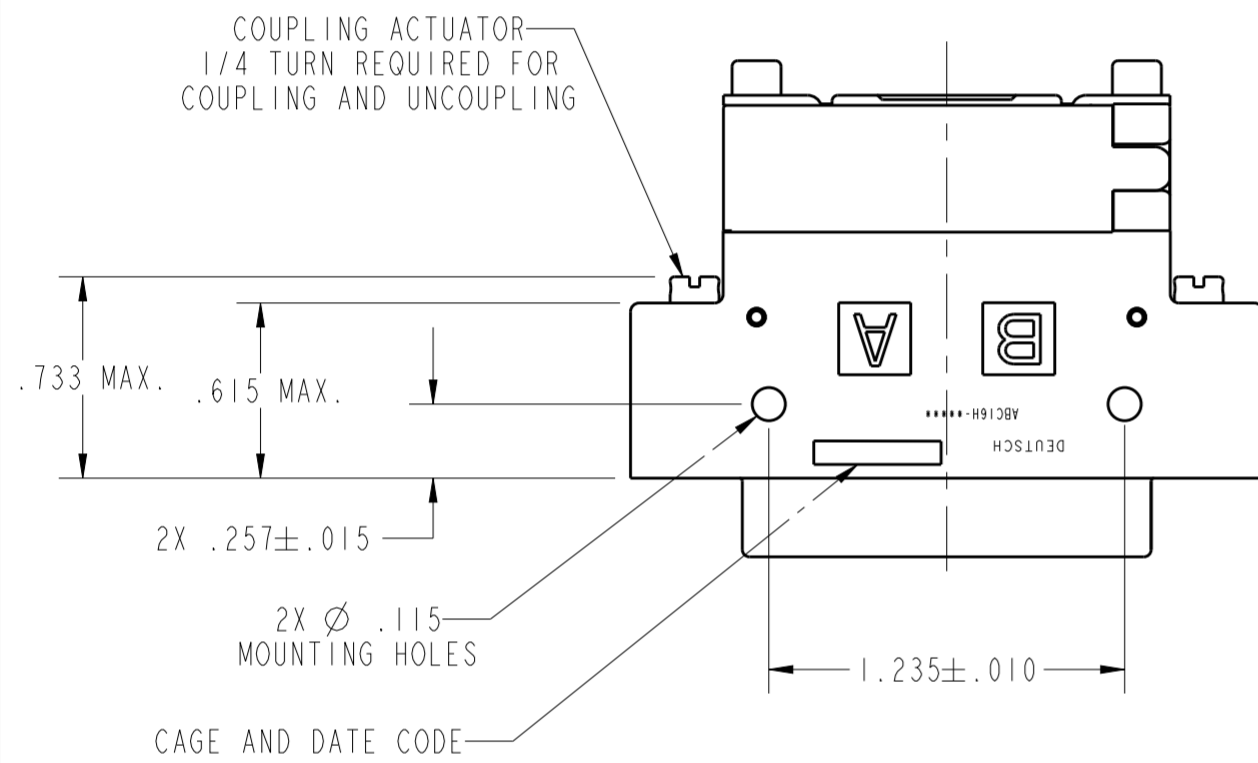
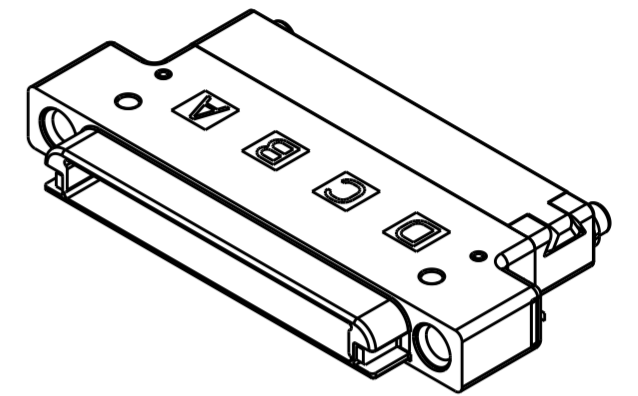
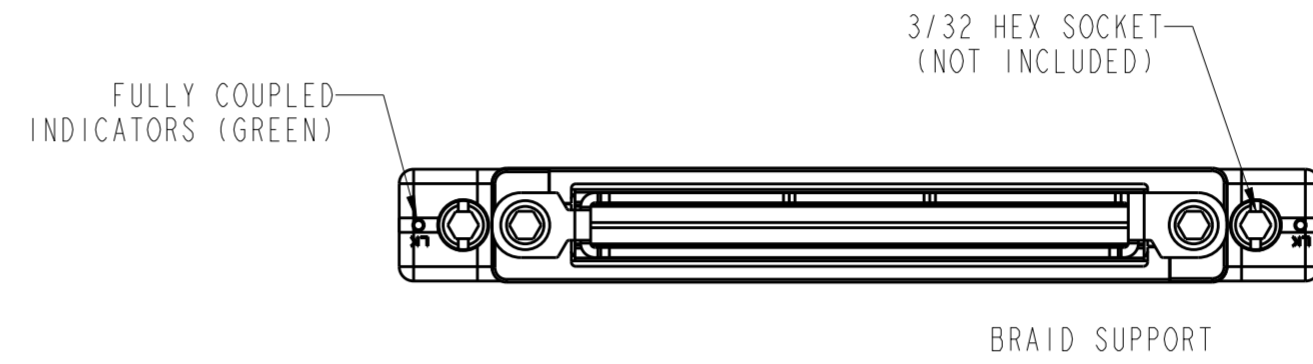
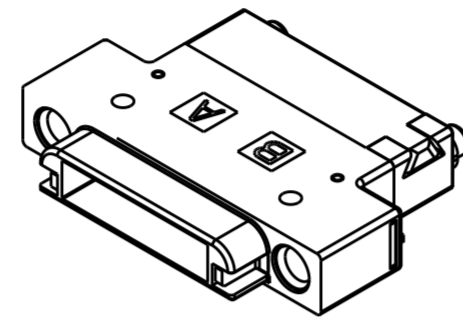
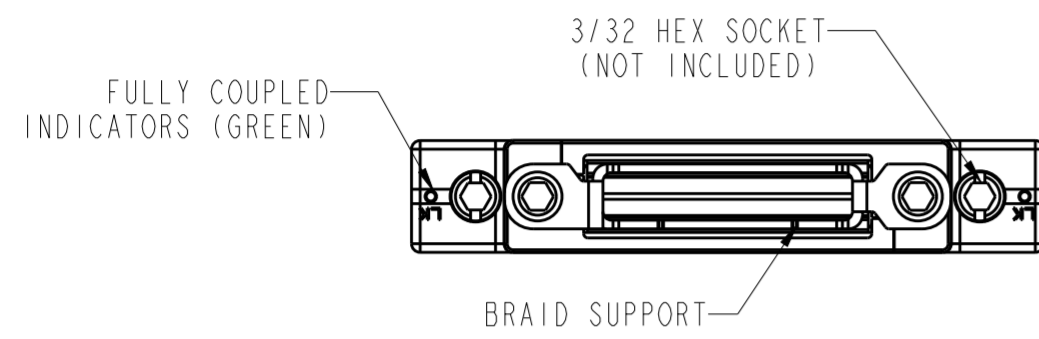

NOTES: UNLESS OTHERWISE SPECIFIED (CONTINUED)

3. MATERIALS/FINISHES:

ONE INCH AND TWO INCH SHELLS:
 SHELL - GLASS FILLED THERMOPLASTIC/ ELECTROLYTIC NICKEL
 MOUNTING HARDWARE - STAINLESS STEEL
 CONTACTS - COPPER ALLOY/ GOLD OVER NICKEL
 BRAID SUPPORT - STAINLESS STEEL/ PASSIVATED

4. SEE DRAWING 3125-202-0000 FOR ASSEMBLY AND INSTALLATION PROCEDURES

MC: 31 FINISH: SEE NOTES

DESCRIPTION:
 ONE AND TWO INCH
 PLUG SHELL
 ENVELOPE DIMENSIONS
 CAGE CODE: 11139

THIS DRAWING IS A CONTROLLED DOCUMENT.		DWN -	STE TE Connectivity	
DIMENSIONS: INCHES		CHK -		
TOLERANCES UNLESS OTHERWISE SPECIFIED:		APVD -	NAME	
0 PLC ±	1 PLC ±0.1	PRODUCT SPEC	ABC INFORMATION DRAWING	
2 PLC ±0.01	3 PLC ±0.001	TEC 108-32084	HALF, ONE, AND TWO INCH CONNTRS	
4 PLC ±0.0001	ANGLES ±	APPLICATION SPEC	AND MODULE CONFIGURATIONS	
FINISH	SEE NOTES	TEC 108-32084	SIZE	CAGE CODE
MATERIAL	SEE NOTES	WEIGHT	A2	-
Customer Drawing		SCALE	2.000	SHEET
				2 OF 6
				REV J

THIS DRAWING IS UNPUBLISHED. RELEASED FOR PUBLICATION 20
 © COPYRIGHT 20 BY - ALL RIGHTS RESERVED.

REVISIONS				
P	LTR	DESCRIPTION	DATE	APVD
-	-	SEE SHEET 1	-	-

ONE INCH RECEPTACLE ABC13H-xxxxx

TWO INCH RECEPTACLE ABC23H-xxxxx

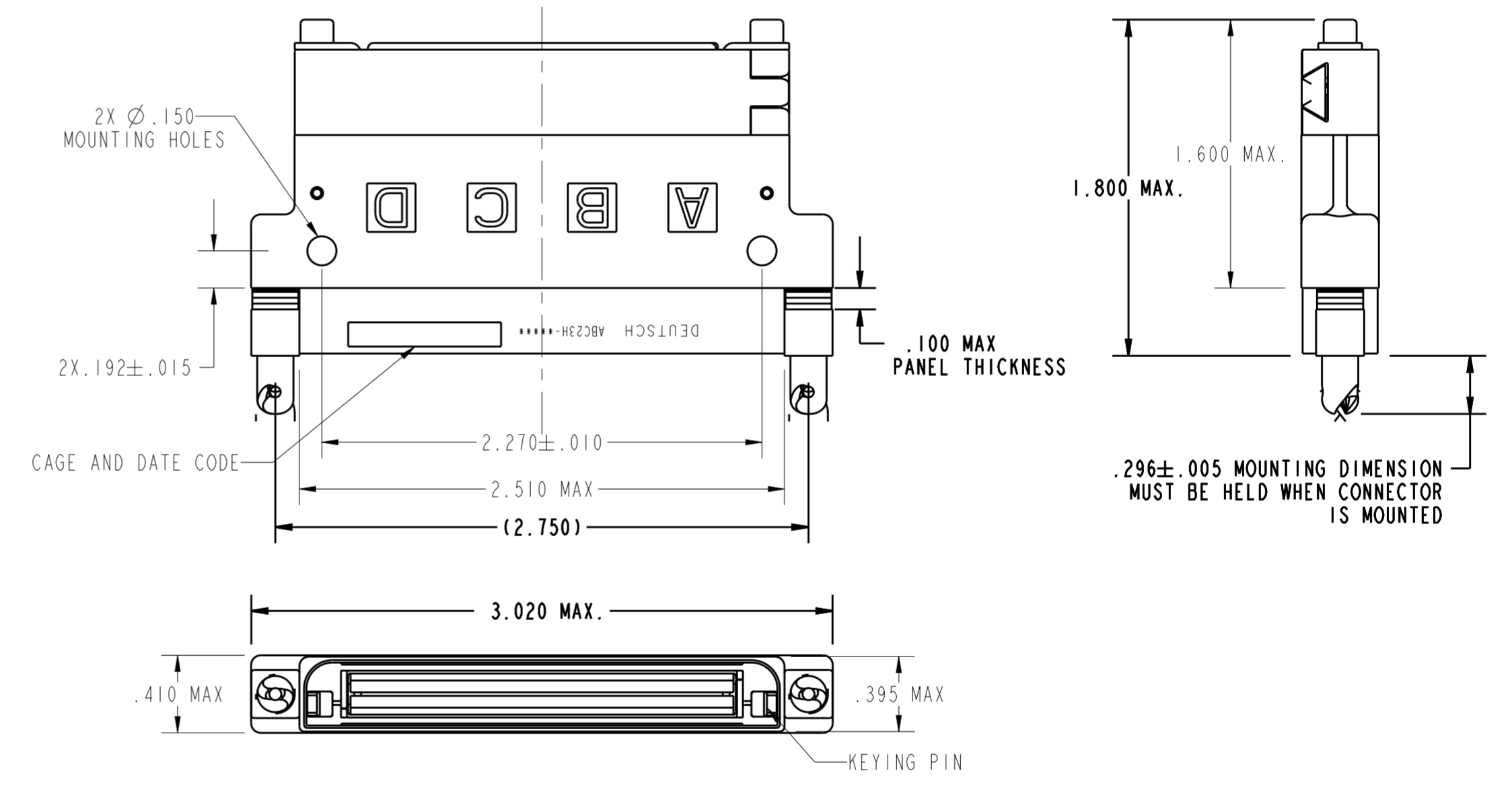
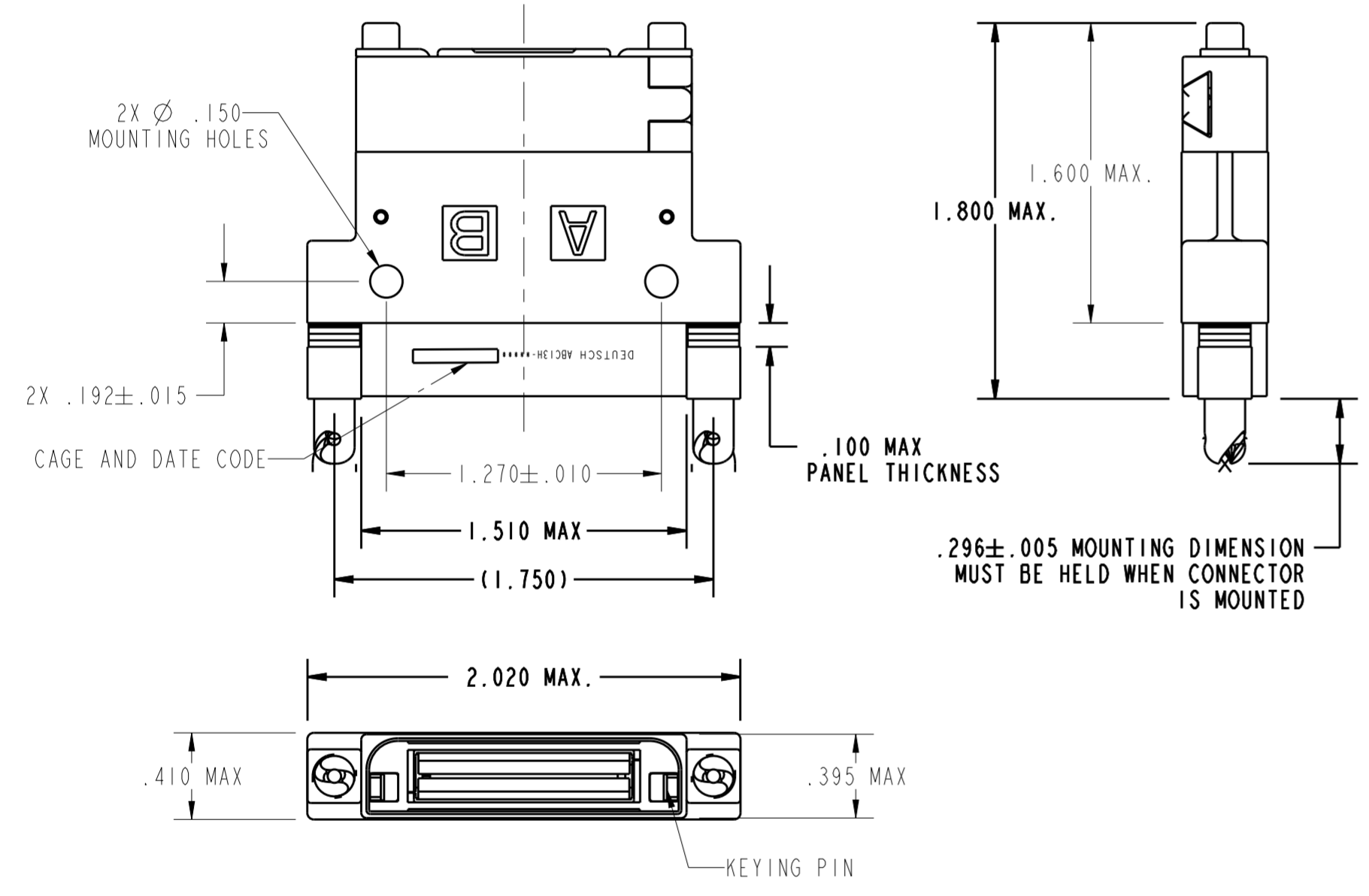
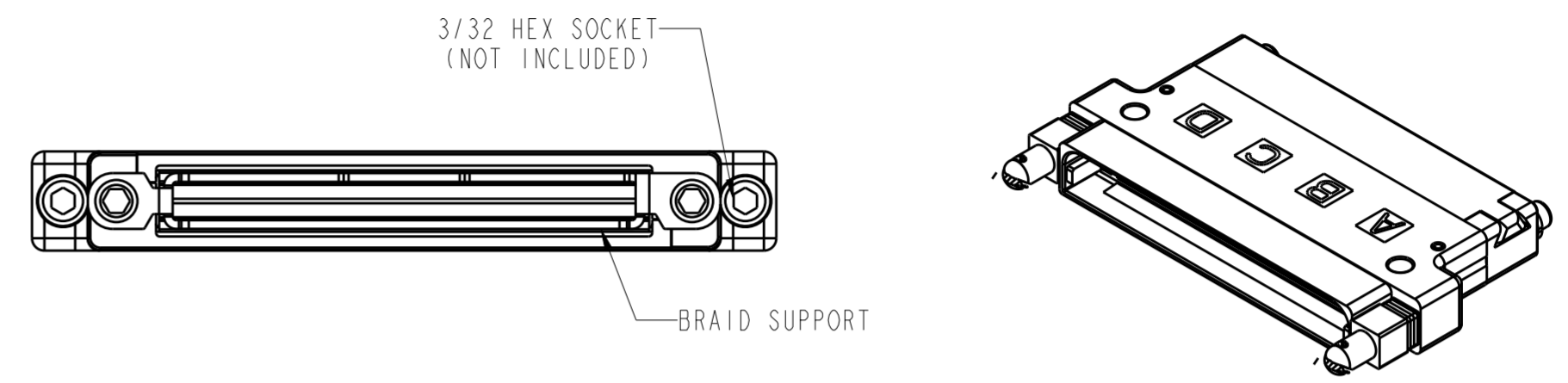
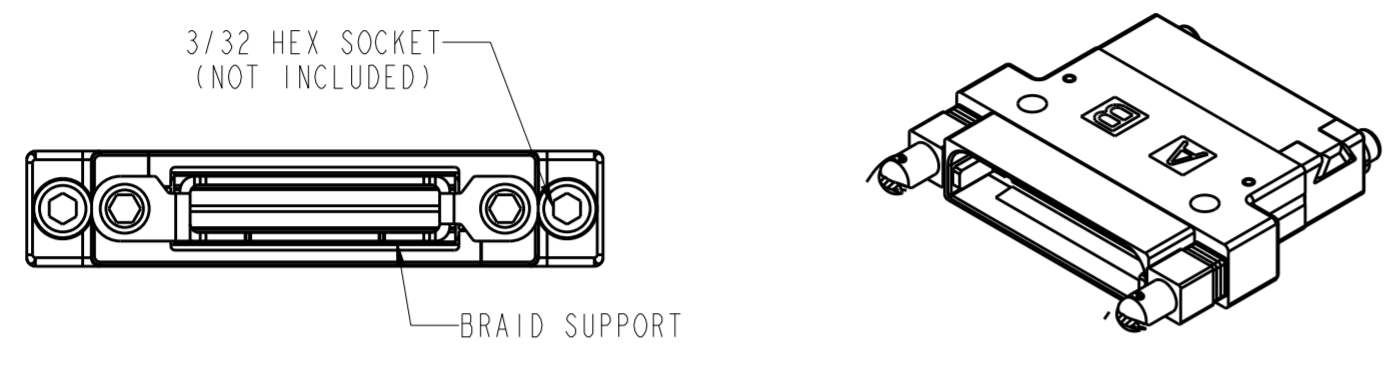

NOTES: SEE PREVIOUS SHEETS

MC: 31	FINISH: SEE NOTES
DESCRIPTION: ONE AND TWO INCH RECEPTACLE SHELL ENVELOPE DIMENSIONS	
CAGE CODE: 11139	

THIS DRAWING IS A CONTROLLED DOCUMENT.		DWN -	STE TE Connectivity	
DIMENSIONS: INCHES		CHK -		
TOLERANCES UNLESS OTHERWISE SPECIFIED:		APVD -	NAME	
0 PLC ±	1 PLC ±.1	PRODUCT SPEC		ABC INFORMATION DRAWING HALF, ONE, AND TWO INCH CONNTRS AND MODULE CONFIGURATIONS
2 PLC ±.01	3 PLC ±.001	TEC 108-32084		
4 PLC ±.0001	ANGLES ±	APPLICATION SPEC		SIZE
FINISH	SEE NOTES	TEC 108-32084		CAGE CODE
MATERIAL	SEE NOTES	WEIGHT		DRAWING NO
SEE NOTES		Customer Drawing		RESTRICTED TO
SCALE 1.000		SHEET 3 OF 6		REV J

THIS DRAWING IS UNPUBLISHED. RELEASED FOR PUBLICATION 20
 © COPYRIGHT 20 BY - ALL RIGHTS RESERVED.

REVISIONS				
P	LTR	DESCRIPTION	DATE	APVD
-	-	SEE SHEET 1	-	-

HALF INCH, IN-LINE RECEPTACLE ABC03x - xxx

HALF INCH, IN-LINE PLUG ABC06x - xxx

INK COLOR CODE
WHEN APPLICABLE

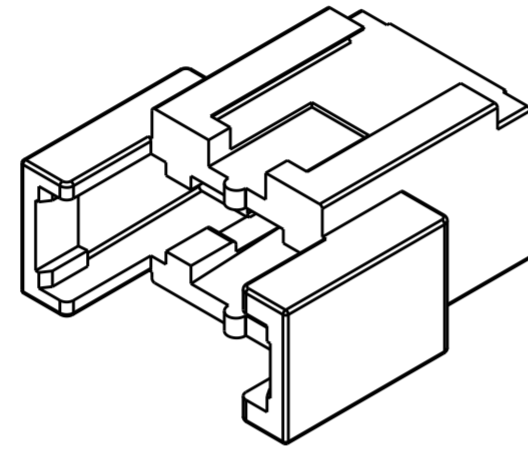
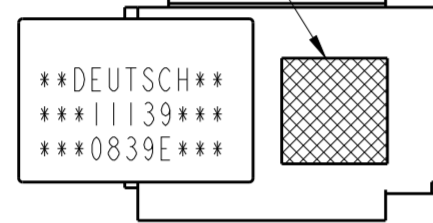

INK COLOR CODE
WHEN APPLICABLE

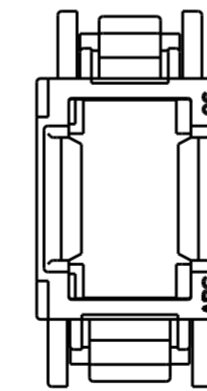
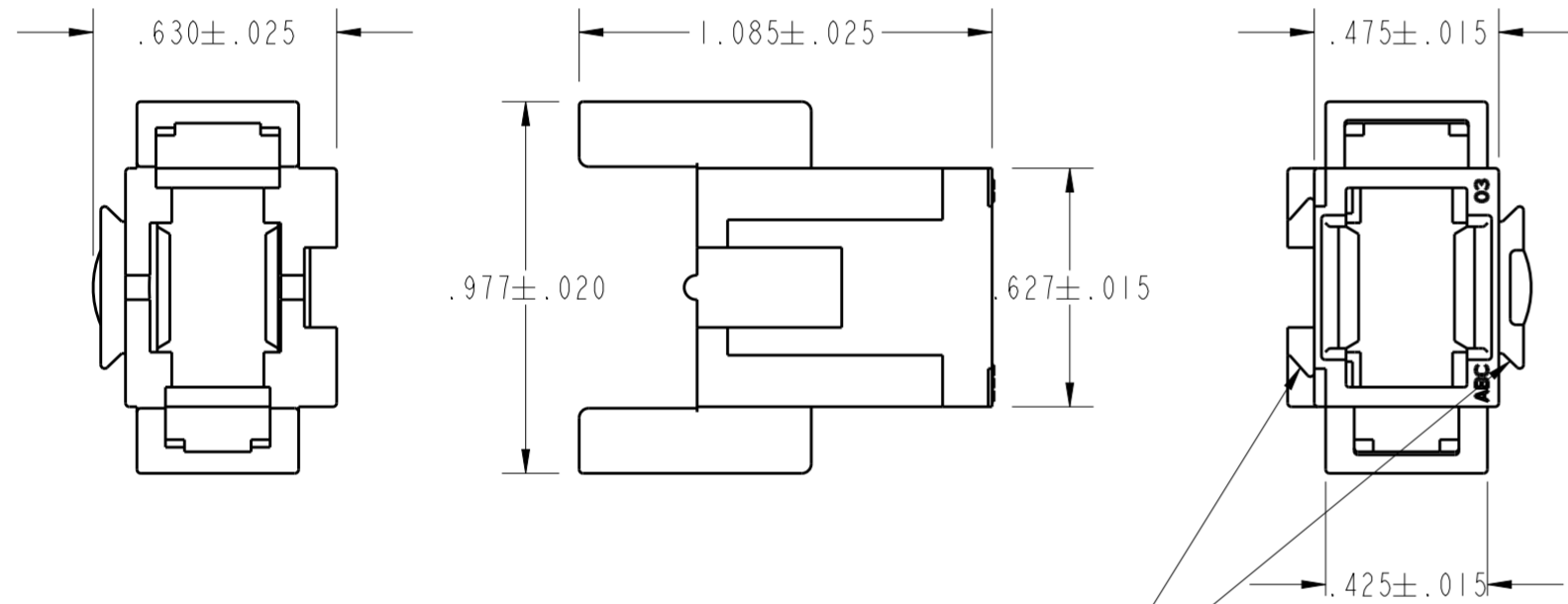
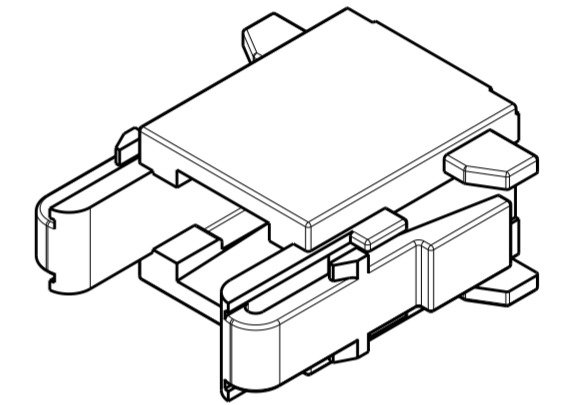
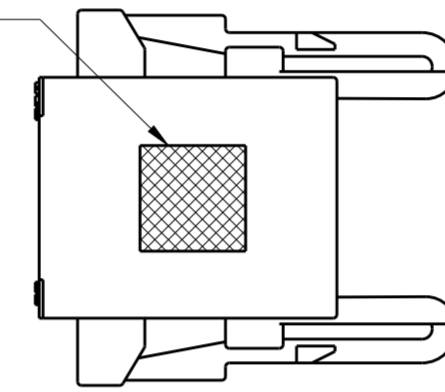

PRINTED PART NUMBER ONLY
WHEN ORDERED WITH MODULE
AND/OR MODIFICATION

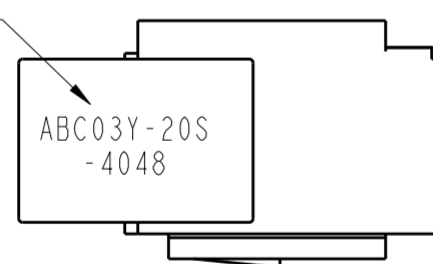

INTERLOCKING DESIGN
FOR STACKING AND MOUNTING

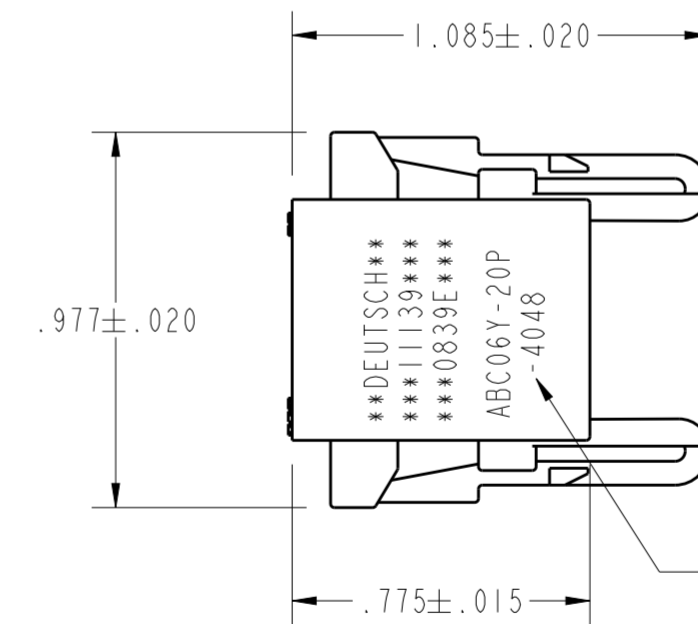

PRINTED PART NUMBER ONLY
WHEN ORDERED WITH MODULE
AND/OR MODIFICATION

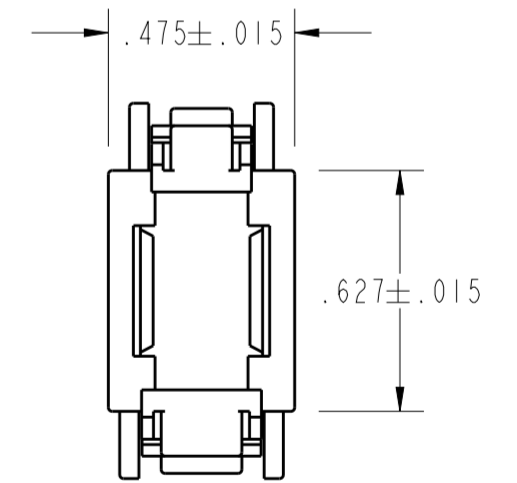

NOTES: UNLESS OTHERWISE SPECIFIED (CONTINUED)

5. MATERIALS/FINISHES:

HALF INCH IN-LINE SHELLS:
SHELL- CHEMICAL RESISTANT THERMOPLASTIC

6. FOR ADDITIONAL INFORMATION, SEE INFORMATION DRAWING 3125-213-0000.

7. ACCEPTS ALL 1/2" MODULES. MODULES ARE NOT REMOVEABLE ONCE INSTALLED.

MC: 31 FINISH: SEE NOTES

DESCRIPTION:
HALF INCH PLUG AND
RECEPTACLE SHELL
ENVELOPE DIMENSIONS
CAGE CODE: 11139

THIS DRAWING IS A CONTROLLED DOCUMENT.		DWN -	TE Connectivity	
DIMENSIONS: INCHES		CHK -		
	TOLERANCES UNLESS OTHERWISE SPECIFIED:	APVD -	NAME	
	0 PLC ± -	PRODUCT SPEC	ABC INFORMATION DRAWING	
	1 PLC ± 0.1	TEC 108-32084	HALF, ONE, AND TWO INCH CONNTRS	
	2 PLC ± 0.01	APPLICATION SPEC	AND MODULE CONFIGURATIONS	
3 PLC ± 0.001	TEC 108-32084	SIZE	CAGE CODE	DRAWING NO
4 PLC ± 0.0001	WEIGHT	A2	-	55500_DEUTSCH
ANGLES ± -	FINISH	Customer Drawing	SCALE	SHEET
SEE NOTES	SEE NOTES	1.000	4 OF 6	REV J

THIS DRAWING IS UNPUBLISHED. RELEASED FOR PUBLICATION
 © COPYRIGHT 20 BY - ALL RIGHTS RESERVED.

REVISIONS				
P	LTR	DESCRIPTION	DATE	APVD
-	-	SEE SHEET 1	-	-

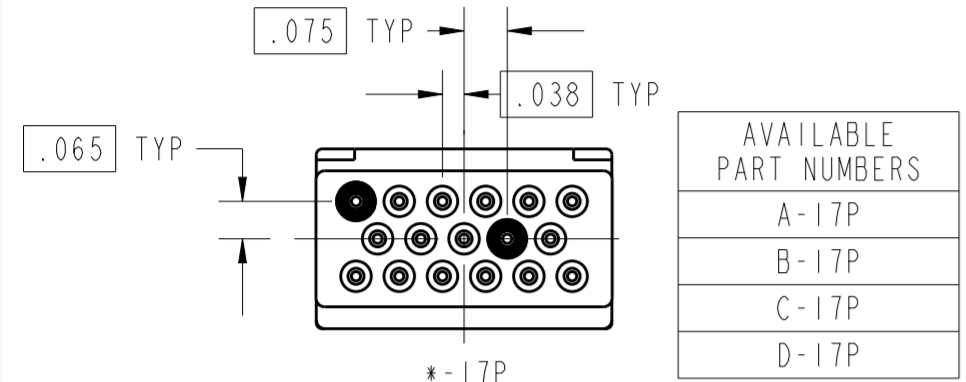

AVAILABLE PART NUMBERS
A-17P
B-17P
C-17P
D-17P

*-17P
 17 SIZE 22 CAVITIES
 FIRST AND TENTH CAVITIES ARE IDENTIFIED
 (MODULE ACCEPTS CONTACT
 PART NUMBER 2841-5-9000 ONLY)

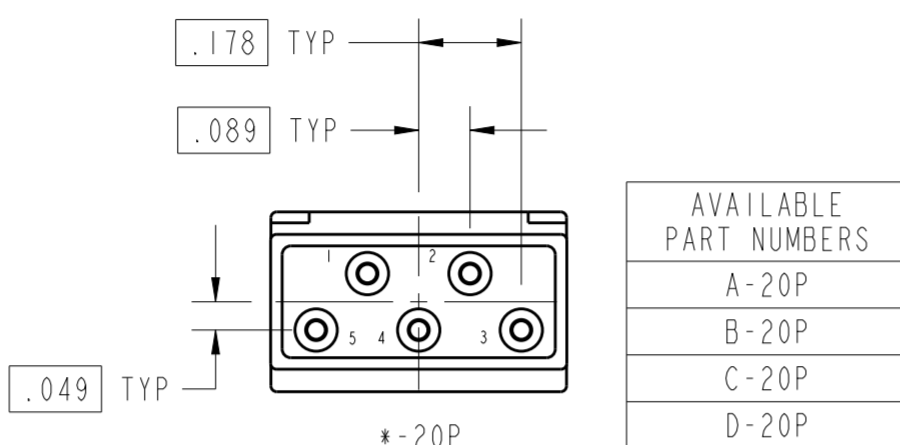

AVAILABLE PART NUMBERS
A-20P
B-20P
C-20P
D-20P

*-20P
 5 SIZE 20 CAVITIES

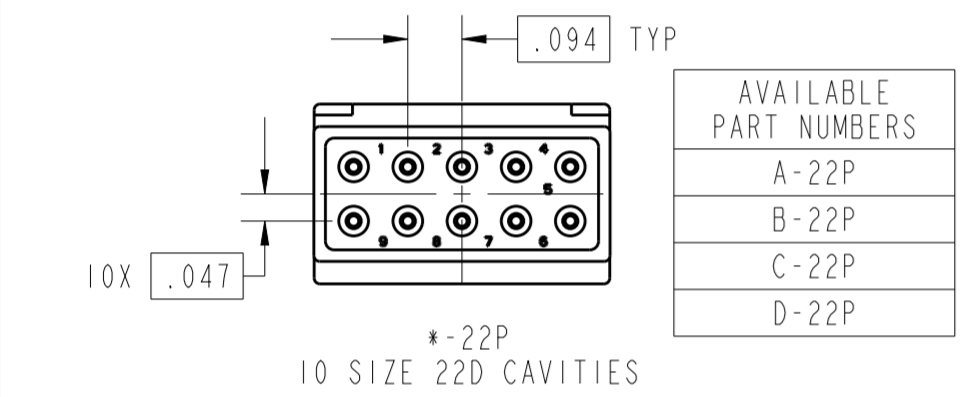

AVAILABLE PART NUMBERS
A-22P
B-22P
C-22P
D-22P

*-22P
 10 SIZE 22D CAVITIES

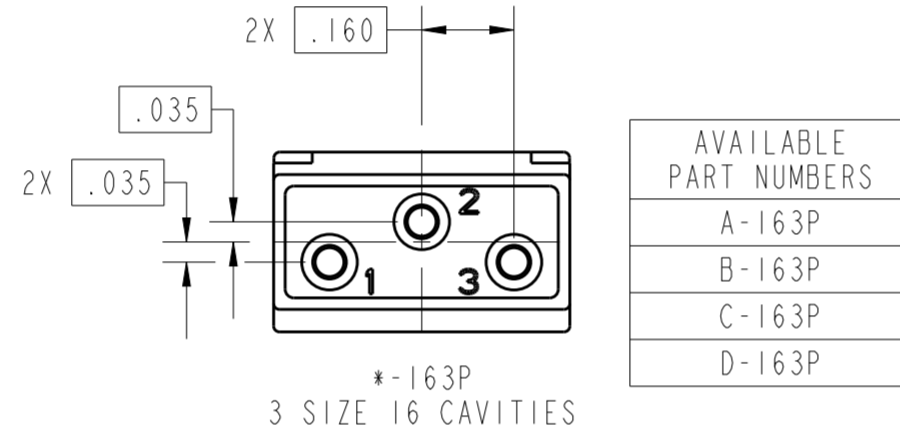

AVAILABLE PART NUMBERS
A-163P
B-163P
C-163P
D-163P

*-163P
 3 SIZE 16 CAVITIES

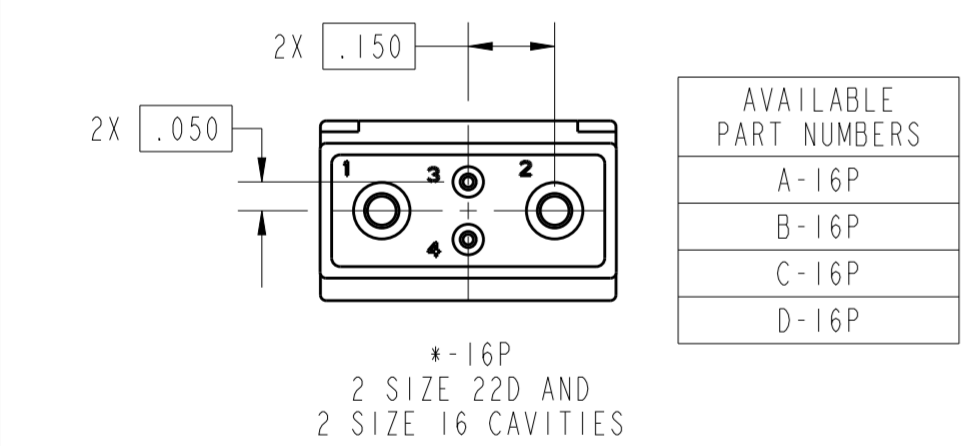

AVAILABLE PART NUMBERS
A-16P
B-16P
C-16P
D-16P

*-16P
 2 SIZE 22D AND
 2 SIZE 16 CAVITIES

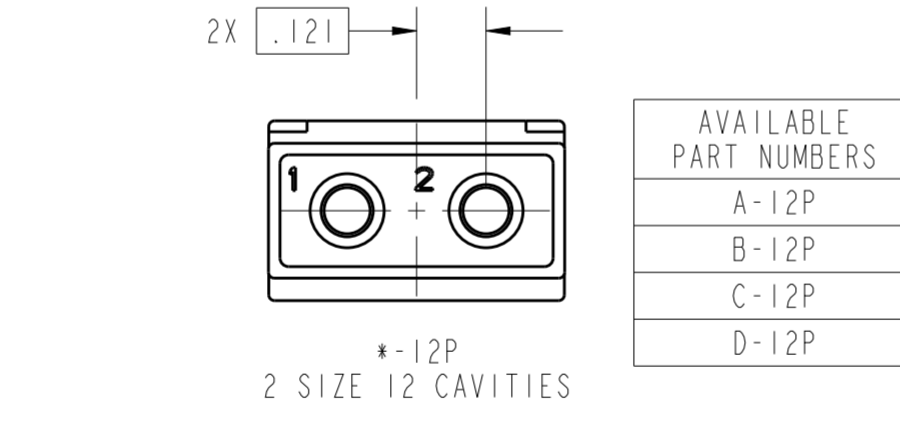

AVAILABLE PART NUMBERS
A-12P
B-12P
C-12P
D-12P

*-12P
 2 SIZE 12 CAVITIES

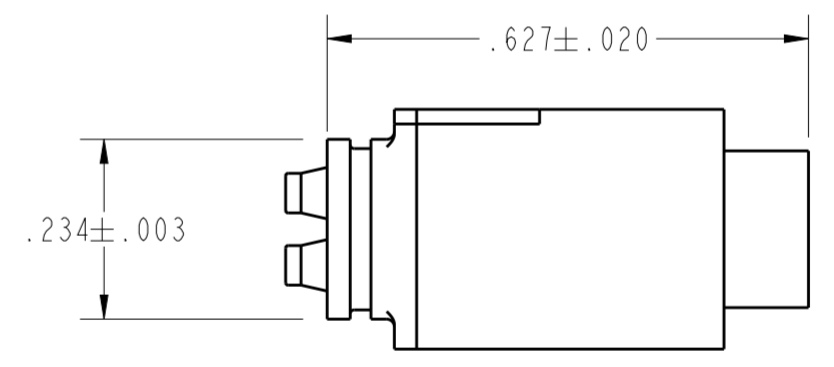
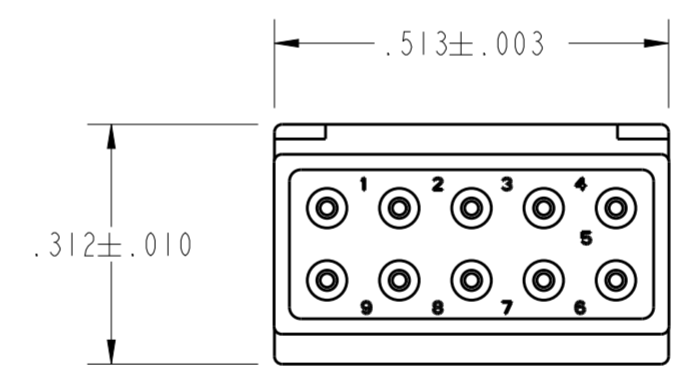
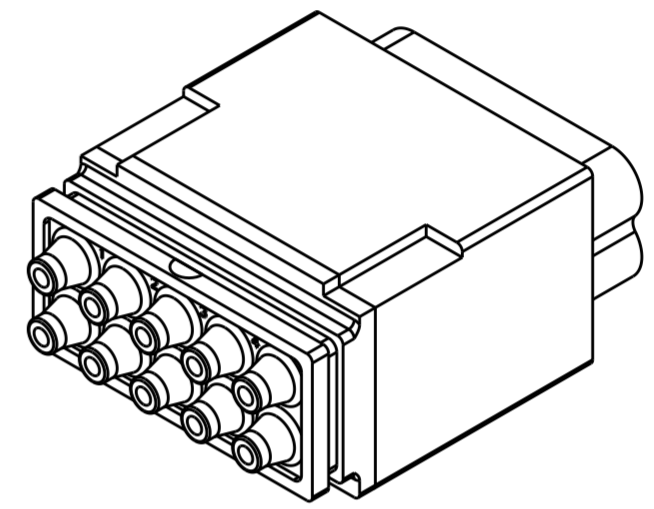
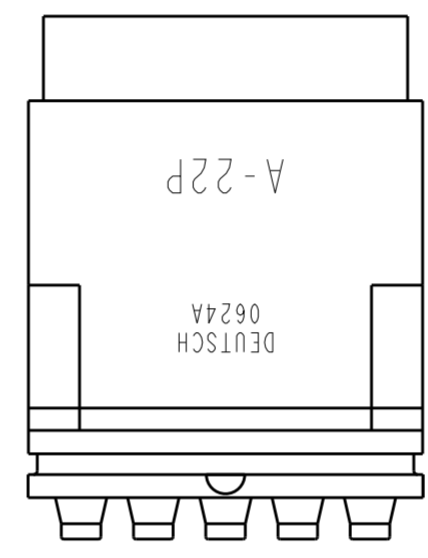

DIMENSIONS APPLY TO ALL 1/2" PIN MODULES
 (CONFIGURATION *-22P SHOWN)

NOTES: UNLESS OTHERWISE SPECIFIED (CONTINUED)

8. MATERIALS/FINISHES:

HALF INCH MODULES:
 HOUSING- GLASS FILLED THERMOPLASTIC
 ELASTOMER- FLOUROSILICONE BLEND

9. FOR PIN MODULES, CAVITY IDENTIFICATIONS SHOWN ARE ON THE FRONT FACE OF THE PIN INSERT. FOR SOCKET MODULES, CAVITY IDENTIFICATIONS SHOWN ARE ON THE FRONT FACE OF THE SOCKET INSERT.

MC: 31	FINISH: SEE NOTES
DESCRIPTION: HALF INCH PIN MODULE ENVELOPE DIMENSIONS CONFIG. 17, 22, 16, 20, 163 & 12	
CAGE CODE: 11139	

THIS DRAWING IS A CONTROLLED DOCUMENT.		DWN	TE Connectivity	
DIMENSIONS: INCHES		CHK	NAME	
TOLERANCES UNLESS OTHERWISE SPECIFIED:		APVD	ABC INFORMATION DRAWING	
0 PLC ± -	1 PLC ± 0.1	PRODUCT SPEC	HALF, ONE, AND TWO INCH CONNTRS	
2 PLC ± 0.01	3 PLC ± 0.001	APPLICATION SPEC	AND MODULE CONFIGURATIONS	
4 PLC ± 0.0001	ANGLES ± -	TEC 108-32084	SIZE	CAGE CODE
FINISH	SEE NOTES	TEC 108-32084	A2	55500_DEUTSCH
MATERIAL	SEE NOTES	WEIGHT	DRAWING NO	RESTRICTED TO
		Customer Drawing	SCALE 1.000	SHEET 5 OF 6
			REV J	

THIS DRAWING IS UNPUBLISHED. RELEASED FOR PUBLICATION
 © COPYRIGHT 20 BY - ALL RIGHTS RESERVED.

REVISIONS				
P	LTR	DESCRIPTION	DATE	APVD
-	-	SEE SHEET 1	-	-

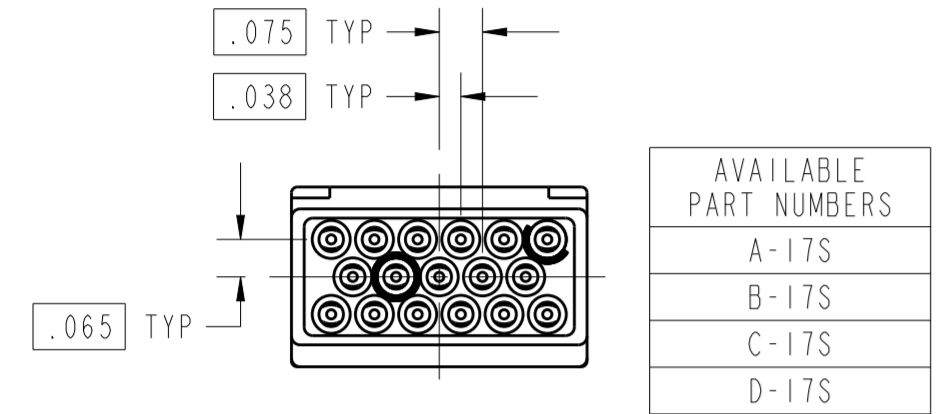

AVAILABLE PART NUMBERS
A-17S
B-17S
C-17S
D-17S

*-17S
 FIRST AND TENTH CAVITIES ARE IDENTIFIED
 (MODULE ACCEPTS CONTACT
 PART NUMBER 2803-4-0000 ONLY)

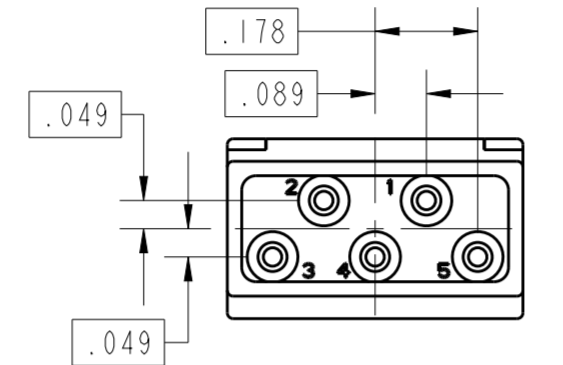

AVAILABLE PART NUMBERS
A-20S
B-20S
C-20S
D-20S

*-20S
 5 SIZE 20 CAVITIES

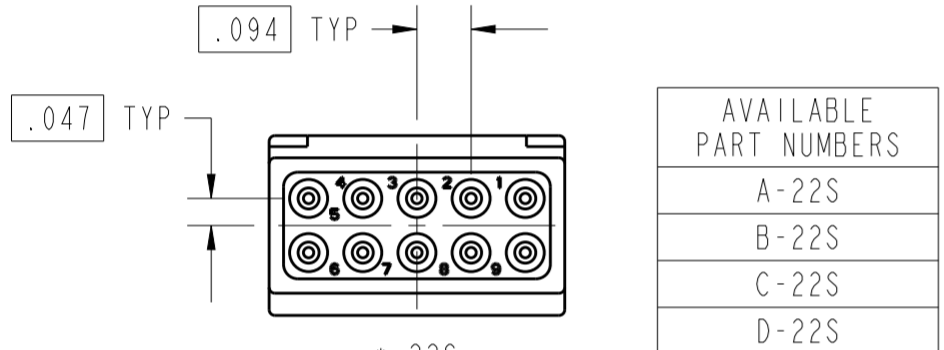

AVAILABLE PART NUMBERS
A-22S
B-22S
C-22S
D-22S

*-22S
 10 SIZE 22D CAVITIES

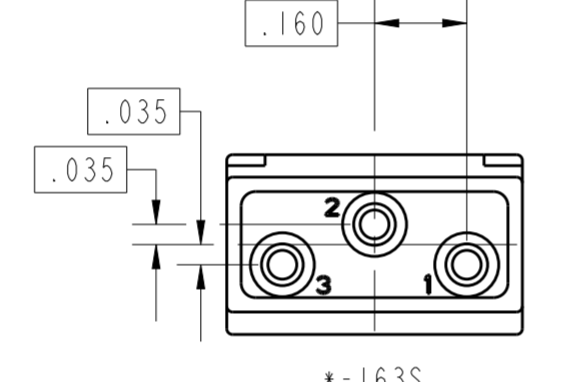

AVAILABLE PART NUMBERS
A-163S
B-163S
C-163S
D-163S

*-163S
 3 SIZE 16 CAVITIES

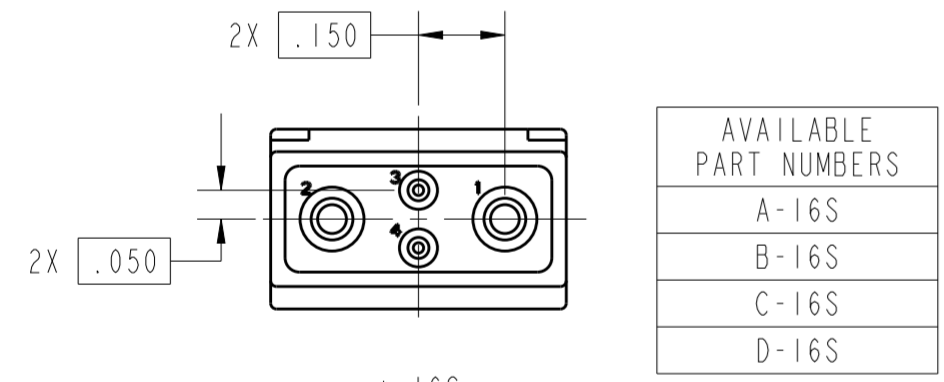

AVAILABLE PART NUMBERS
A-16S
B-16S
C-16S
D-16S

*-16S
 2 SIZE 22D AND
 2 SIZE 16 CAVITIES

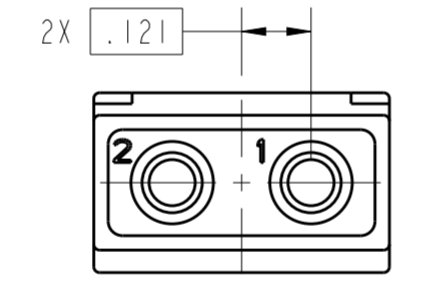

AVAILABLE PART NUMBERS
A-12S
B-12S
C-12S
D-12S

*-12S
 2 SIZE 12 CAVITIES

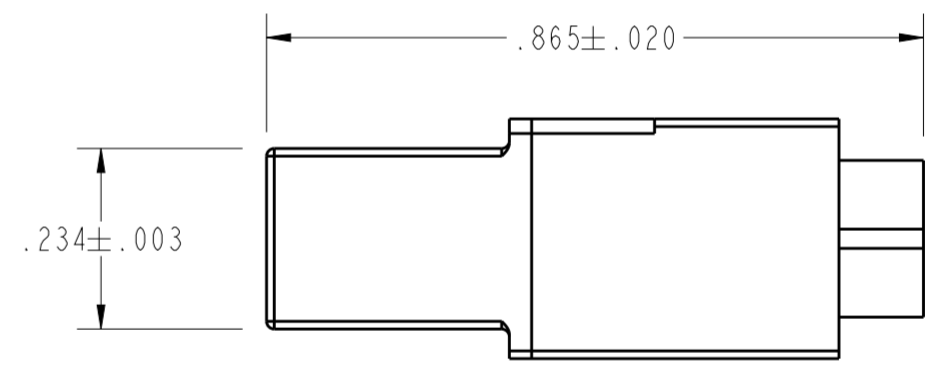
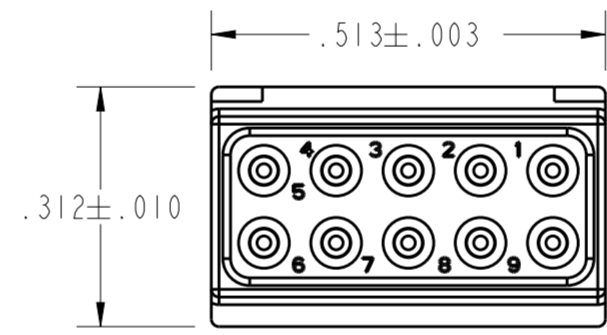
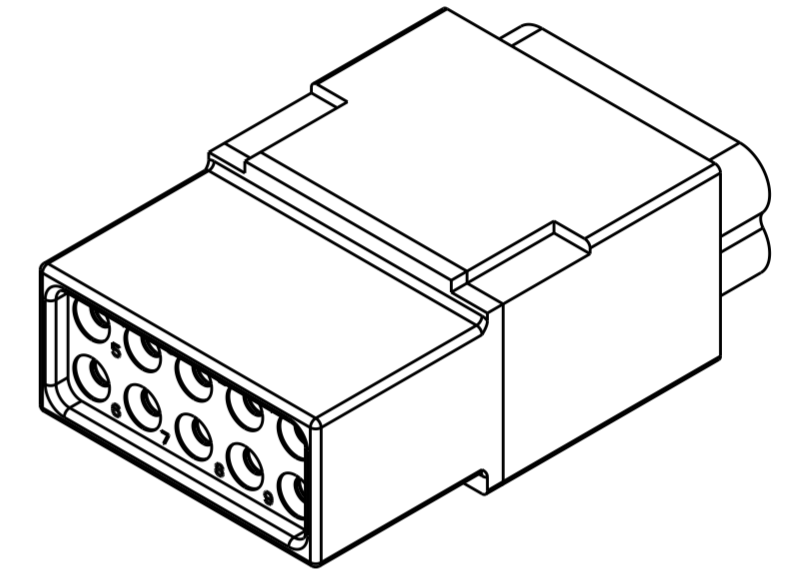
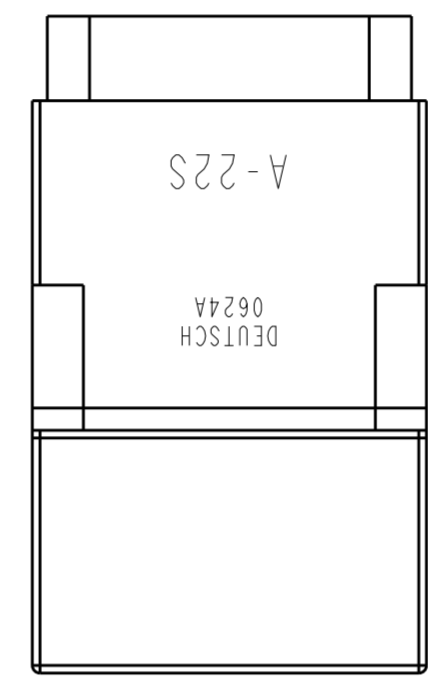

DIMENSIONS APPLY TO ALL 1/2" SOCKET MODULES
 (CONFIGURATION *-22S SHOWN)

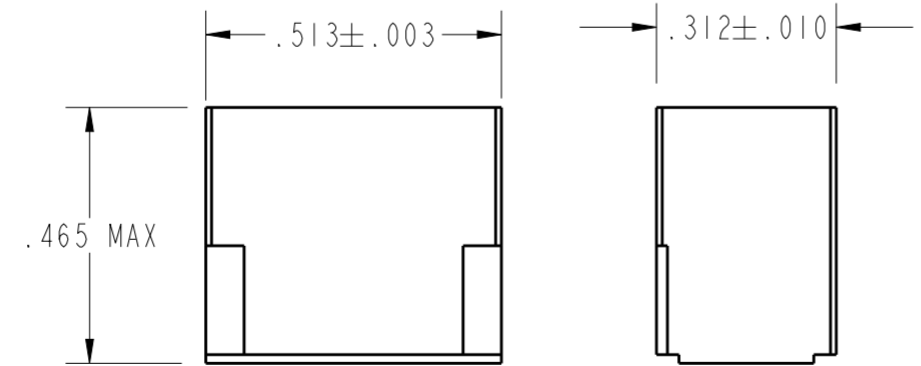

AVAILABLE PART NUMBERS
00B

BLANK FILLER INSERT
 USED IN PLACE FOR PIN OR SOCKET MODULE
 MAY BE USED IN BOTH PLUG AND RECEPTACLE SHELLS

MC: 31	FINISH: SEE NOTES
DESCRIPTION: HALF INCH SOCKET MODULE ENVELOPE DIMENSIONS CONFIG. 17,22,16,20,163 & 12	
CAGE CODE: 11139	

NOTES: SEE PREVIOUS SHEETS

THIS DRAWING IS A CONTROLLED DOCUMENT.		DWN -	STE TE Connectivity	
DIMENSIONS: INCHES		CHK -	NAME: ABC INFORMATION DRAWING	
TOLERANCES UNLESS OTHERWISE SPECIFIED:		APVD -	HALF, ONE, AND TWO INCH CONNTRS	
0 PLC ±	1 PLC ±0.1	PRODUCT SPEC	AND MODULE CONFIGURATIONS	
2 PLC ±0.01	3 PLC ±0.001	TEC 108-32084	SIZE	CAGE CODE
4 PLC ±0.0001	ANGLES ±	APPLICATION SPEC	A2	-
FINISH	SEE NOTES	TEC 108-32084	DRAWING NO	RESTRICTED TO
MATERIAL	SEE NOTES	WEIGHT	Customer Drawing	SCALE 1.000 SHEET 6 OF 6 REV J