

| REVISIONS |     |                           |           |     |      |
|-----------|-----|---------------------------|-----------|-----|------|
| P         | LTR | DESCRIPTION               | DATE      | DWN | APVD |
| H3        |     | REVISED PER ECR-22-139600 | 30NOV2022 | DB  | FF   |

- 1 USE BUDGET FLAG FASTON TERMINAL BASE P/N 521049, IN THIS PRODUCT.
- 2 WIRE SIZE IS #22-#18 AWG
- 3 INSULATION RANGE IS .050-.100 DIA
- 4 FITS .250 X .032 THK FASTON TAB
- 5 ALTERNATIVE HOUSING FORM

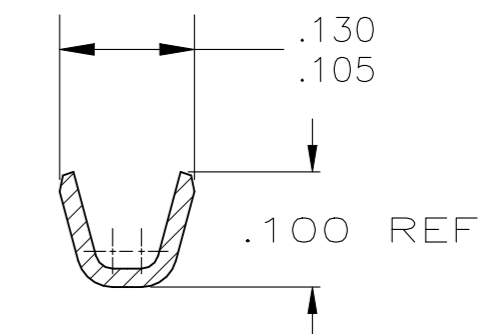

SECTION A-A

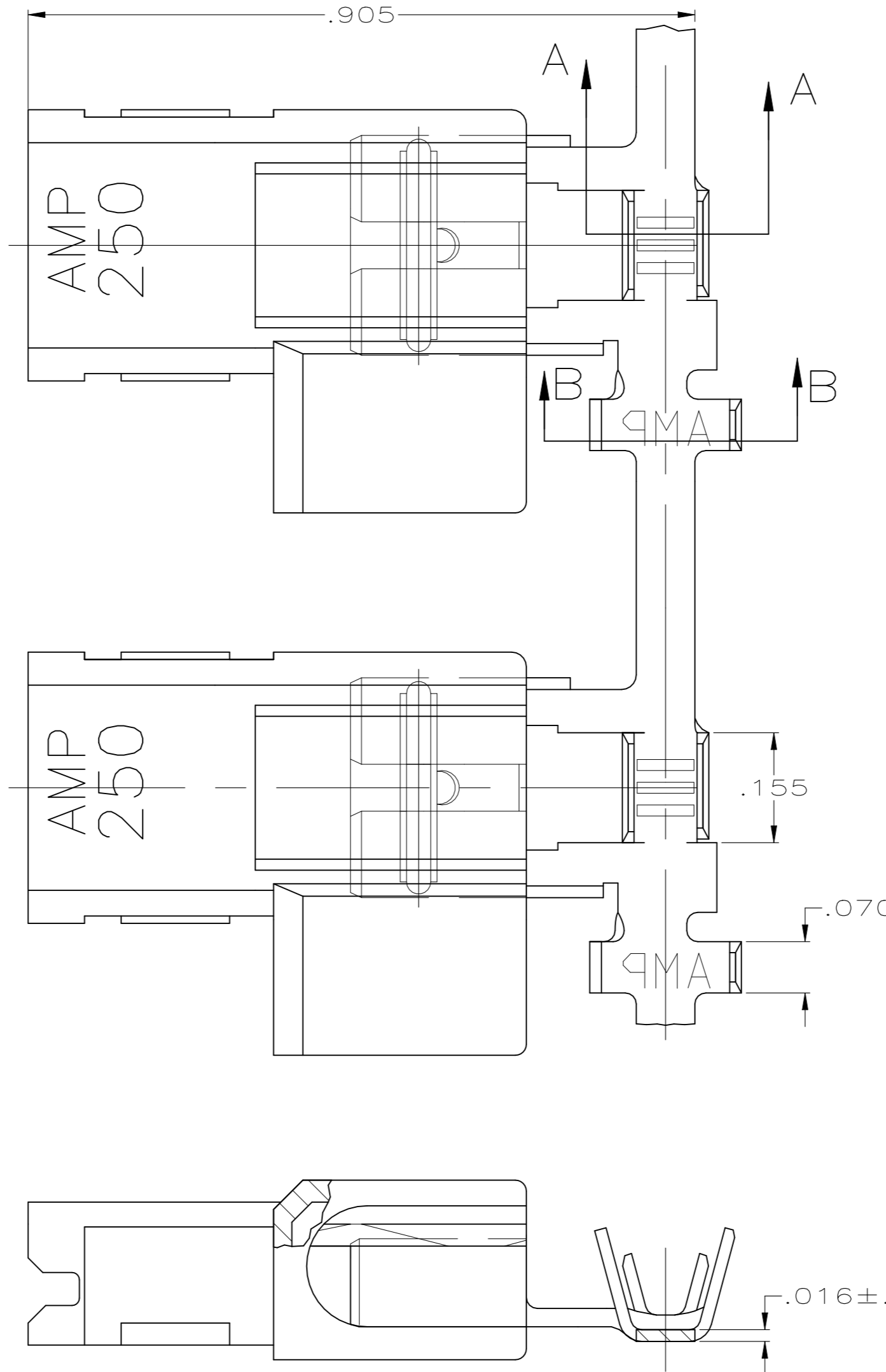
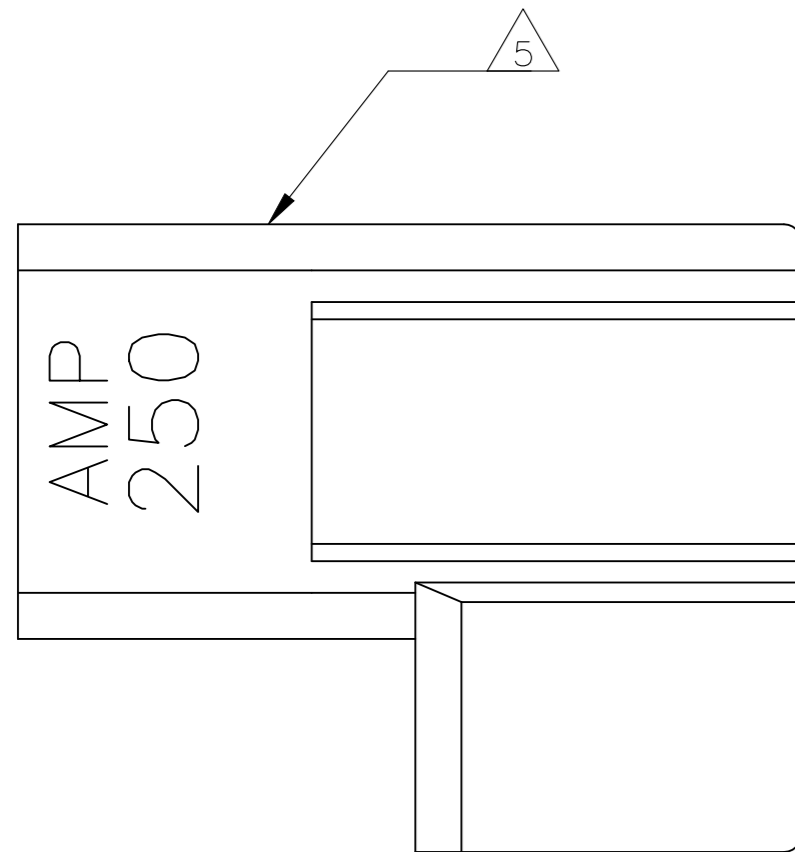
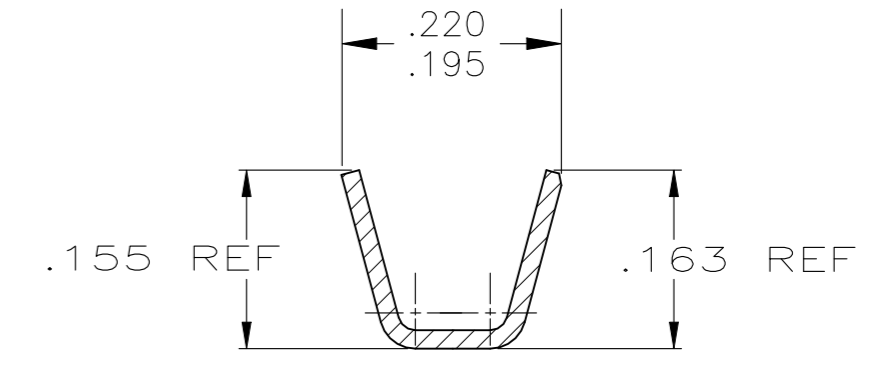

SECTION B-B

|  |  |                              |   |  |
|--|--|------------------------------|---|--|
| 6/6 NYLON / NATURAL                    |  | BRASS - TIN PLATED           | 521050-2  |  |
| SUPERSEDED BY 521050-2                 |  | 6/6 NYLON / NATURAL          | BRASS - PLAIN   |  |
| HOUSING - MATERIAL & FINISH            |  | TERMINAL - MATERIAL & FINISH | PART NO   |  |
| THIS DRAWING IS A CONTROLLED DOCUMENT. |  | DWN<br>JR RUTH<br>7/8/93     | TE Connectivity                                       |  |
| DIMENSIONS:<br>INCHES                  |  | CHK<br>MS FEHER<br>7/8/93    |   |  |
| TOLERANCES UNLESS OTHERWISE SPECIFIED: |  | APVD<br>D BRATINA<br>7/8/93  | NAME  |  |
| 0 PLC ± -                              |  | PRODUCT SPEC                 | ASSEMBLY, RECEPTACLE, FLAG,<br>ULTRA-POD, .250 SERIES |  |
| 1 PLC ± -                              |  | 108-1285                     | SIZE  |  |
| 2 PLC ± -                              |  | APPLICATION SPEC             | CAGE CODE   |  |
| 3 PLC ± 0.25 [.010]                    |  | 114-2124                     | DRAWING NO  |  |
| 4 PLC ± -                              |  | WEIGHT                       | RESTRICTED TO   |  |
| ANGLES ± -                             |  | 0.000000                     | -   |  |
| FINISH                                 |  | CUSTOMER DRAWING             | SCALE   |  |
| SEE TABLE                              |  | SEE TABLE                    | 6:1   |  |
|  |  |                              | SHEET   |  |
|  |  |                              | 1 OF 1  |  |
|  |  |                              | REV   |  |
|  |  |                              | H3  |  |