

P	LTR	DESCRIPTION	DATE	DWN	APVD
	B	INITIAL RELEASE	07JUL2020	SB	LI

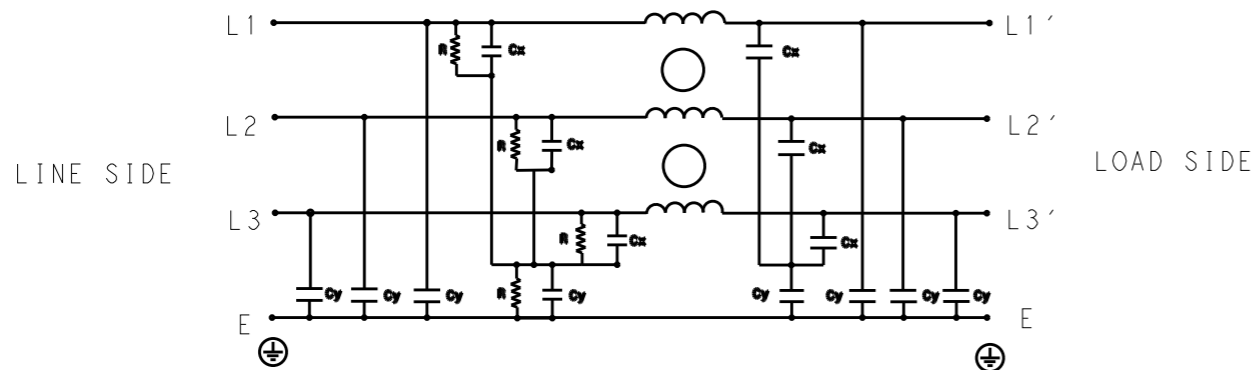

SCHEMATIC

TYPICAL INSERTION LOSS
COMMON MODE 50/50Ω; DIFFERENTIAL MODE 50/50Ω

MHz	0.01	0.05	0.15	0.5	1	3	5	10	30
CM	34	36	42	44	51	47	40	34	30
DM	32	38	51	57	61	54	58	57	44

SAFETY ORGANIZATIONS

THIS FILTER WILL BE FORMALLY RECOGNIZED, CERTIFIED OR APPROVED BY THE LISTED AGENCY. THEREFORE, ALL TEST/REQUIREMENTS SPECIFIED IN THE LATEST REVISION OF THE FOLLOWING AGENCY STANDARDS WILL BE MET:

UL RECOGNIZED* 150A 520V 50Hz/60Hz 40°C
 CSA CERTIFIED** 150A 520V 50Hz/60Hz 40°C

* 31 JULY 2020 ; ** 31 AUGUST 2020

OPERATING SPECIFICATION

LINE CURRENT/VOLTAGE: 150A, 520VAC
 LINE FREQUENCY: 50/60Hz

MAXIMUM LEAKAGE CURRENT: 20mA @ 230VAC, 50Hz

OPERATING AMBIENT TEMPERATURE RANGE @ RATED CURRENT: -25°C TO +40°C

IN AN AMBIENT, T_a, HIGHER THAN 40°C, THE MAXIMUM OPERATING CURRENT, I_o, IS AS FOLLOWS:

$$I_o = I_r \sqrt{\frac{85 - T_a}{45}}$$

RELIABILITY SPECIFICATIONS

STORAGE TEMPERATURE: -40°C TO +85°C
 HUMIDITY: 21 DAYS @ 40°C AND 95% RH

TEST SPECIFICATIONS

INDUCTANCE, NOMINAL: 0.1mH

CAPACITANCE @ 1kHz
 LINE TO GROUND, NOMINAL: 2.04μF
 LINE TO LINE, NOMINAL: 6.8μF

DISCHARGE RESISTOR

L/G I.R. 1MΩ 2W
 L/L I.R. 2MΩ 2W
 L/N I.R. XXX
 N/G I.R. XXX
 IR (NO DISCHARGE RESISTOR) 20°C, 50% RH AND 100VDC, MIN: 6MΩ

RECOMMENDED RECEIVING INSPECITON HIPOT

LINE TO GROUND FOR 1 MINUTE: 2856VDC
 LINE TO LINE FOR 1 MINUTE: 2236VDC

FILTER APPROVAL

THE BEST WAY TO SELECT AND QUALIFY A FILTER IS FOR YOUR ENGINEERING TO TEST THE UNIT IN YOUR EQUIPMENT.

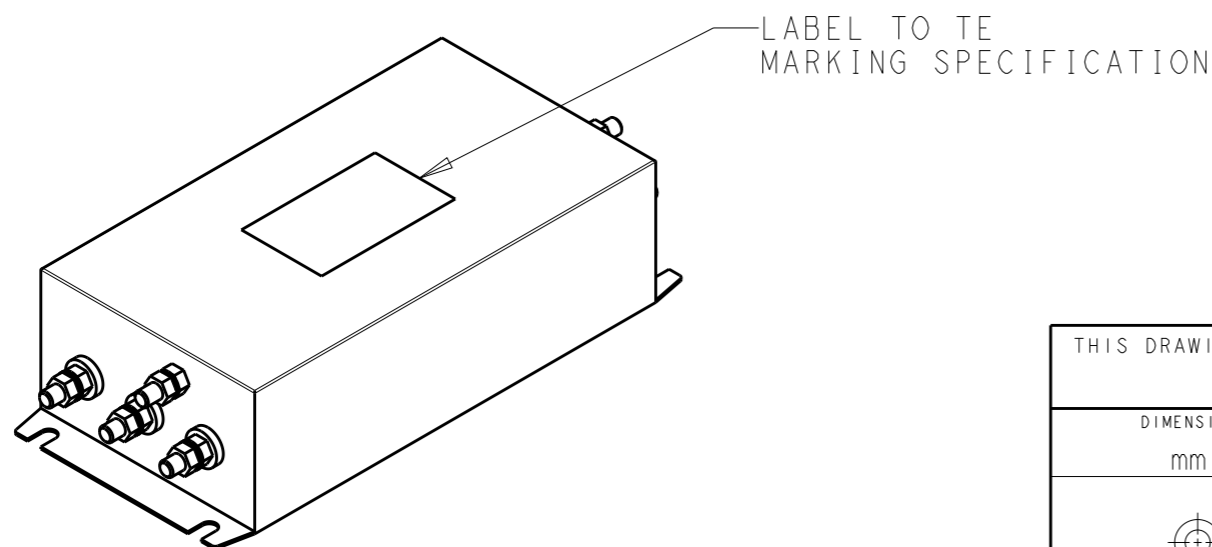

THIS DRAWING IS A CONTROLLED DOCUMENT.		DWN 04MAR2020 SHRICHARANA B	TE Connectivity	
DIMENSIONS: mm		CHK 04MAR2020 LEO IRUDHAYARAJ		
TOLERANCES UNLESS OTHERWISE SPECIFIED:		APVD 04MAR2020 LEO IRUDHAYARAJ	NAME POWER LINE FILTER 150KEMS6BFPD	
0 PLC ±-		PRODUCT SPEC	SIZE	
1 PLC ±0.5		APPLICATION SPEC	CAGE CODE	
2 PLC ±0.40		WEIGHT	DRAWING NO	
3 PLC ±0.130		CUSTOMER DRAWING	RESTRICTED TO	
4 PLC ±0.0500			A300779	
ANGLES ±-			C-5-1609967-4	
MATERIAL			SCALE 1:4	
FINISH			SHEET 1 OF 2	
			REV B	

© 2020 TE Connectivity. All Rights Reserved.

REVISIONS

NOTE 1 GROUND CONNECTION:
DO NOT LOOSEN INNER GROUND NUTS.
TORQUE OUTER TERMINAL /GROUND NUTS: 4-10Nm

NOTE 2 INPUT OUTPUT CONNECTION TERMINAL
AWG SIZE: XXX
THREADED BOLT SIZE FOR TERMINAL: M10
THREADED BOLT SIZE FOR GROUND: M10

P	LTR	DESCRIPTION	DATE	DWN	APVD
		SEE SHEET 1			

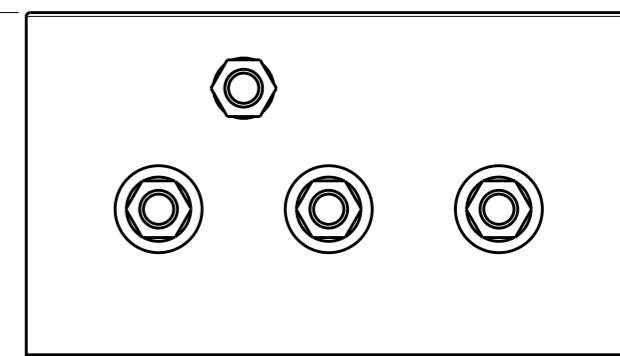
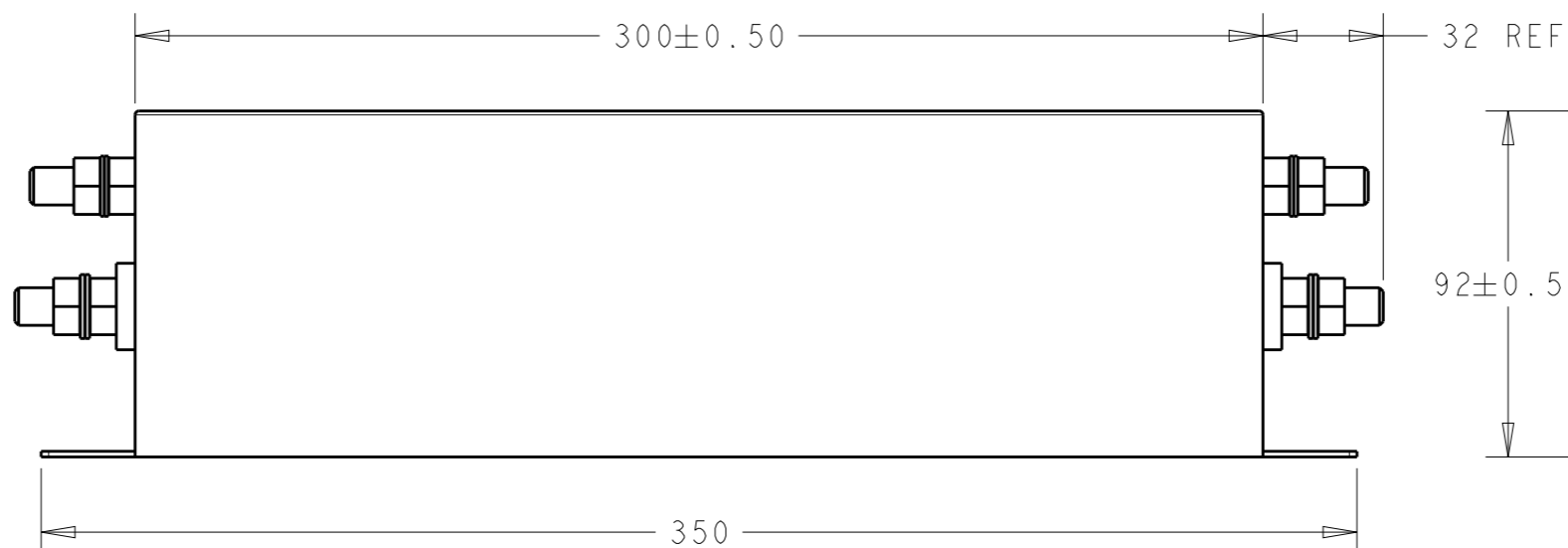
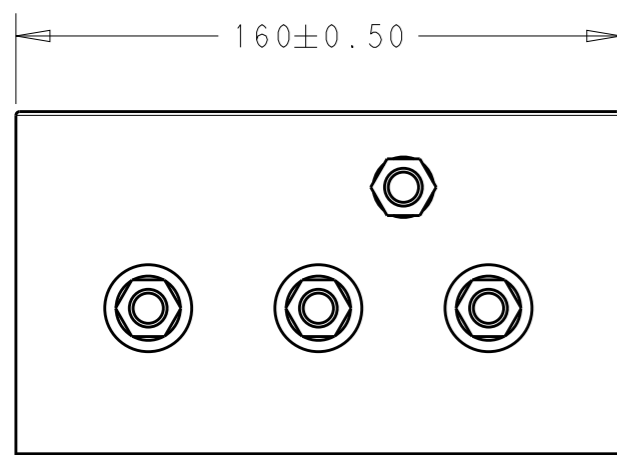
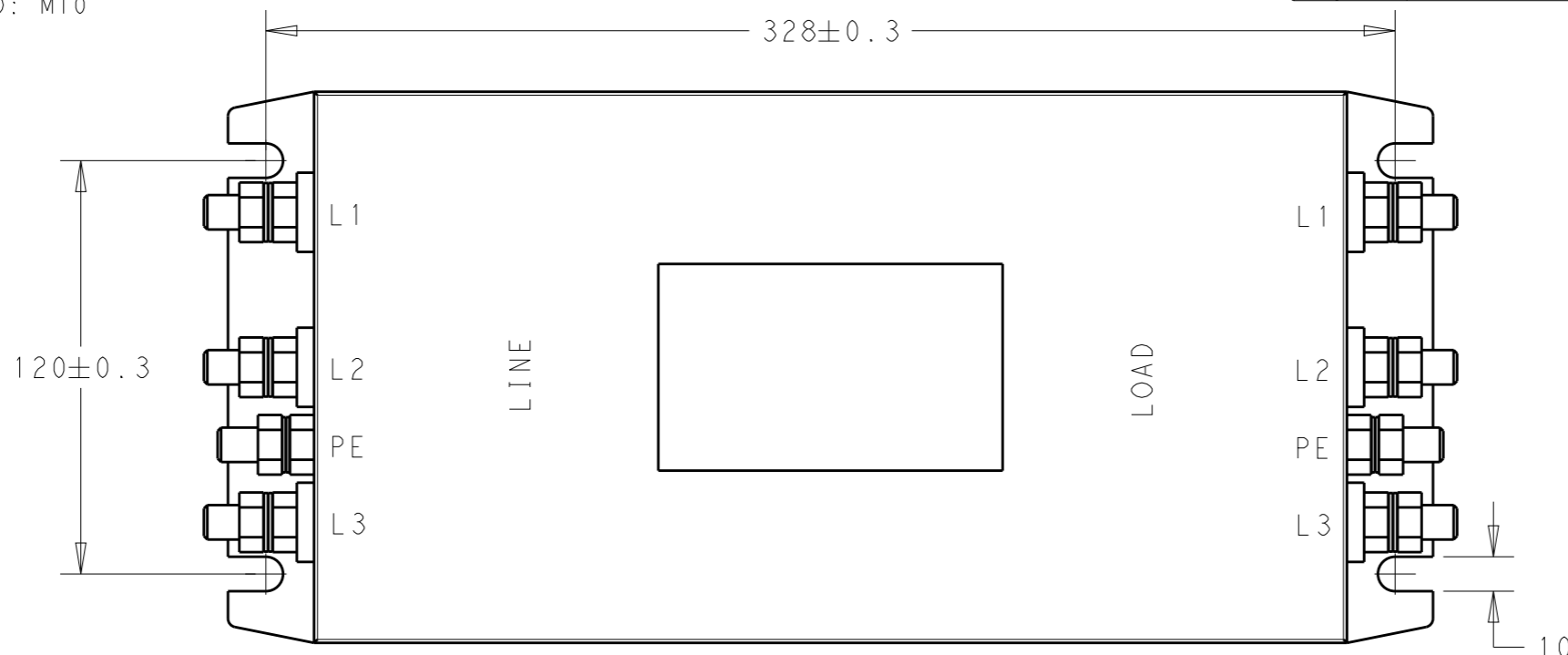

THIS DRAWING IS A CONTROLLED DOCUMENT.

DWN 04MAR2020
SHRICHARANA B
CHK 04MAR2020
LEO IRUDHAYARAJ
APVD 04MAR2020
LEO IRUDHAYARAJ



DIMENSIONS:	TOLERANCES UNLESS OTHERWISE SPECIFIED:
mm	
	0 PLC ±-
	1 PLC ±0.5
	2 PLC ±0.40
	3 PLC ±0.130
	4 PLC ±0.0500
	ANGLES ±-
MATERIAL	FINISH
-	-
-	-

PRODUCT SPEC -

APPLICATION SPEC -

WEIGHT -

CUSTOMER DRAWING

NAME POWER LINE FILTER 150KEMS6BFPD				RESTRICTED TO
SIZE A3	CAGE CODE 00779	DRAWING NO C-5-1609967-4		
SCALE 1:2	SHEET 2 OF 2	REV B		