

P	LTR	DESCRIPTION	DATE	DWN	APVD
	B	INITIAL RELEASE	07JUL2020	SB	LI

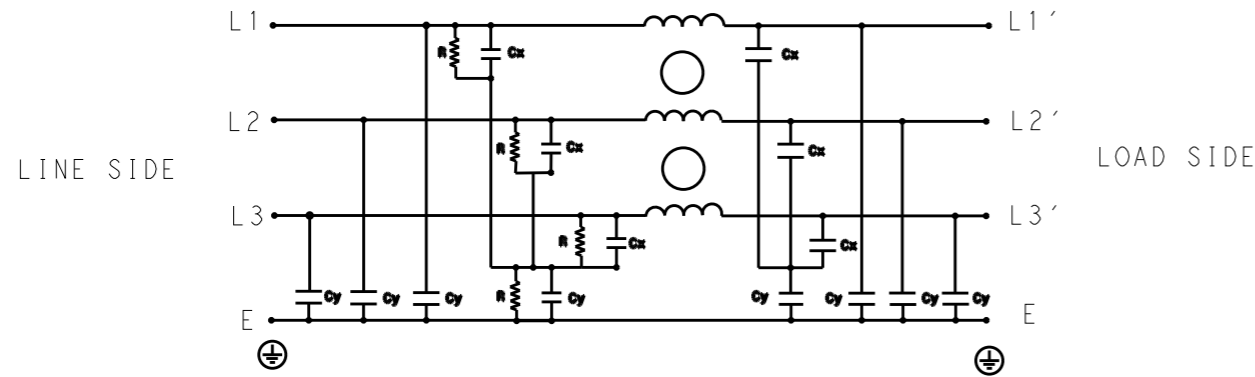

SCHEMATIC

TYPICAL INSERTION LOSS  
COMMON MODE 50/50Ω; DIFFERENTIAL MODE 50/50Ω

MHz	0.01	0.05	0.15	0.5	1	3	5	10	30
CM	36	40	46	48	52	49	40	34	27
DM	37	41	50	55	60	58	56	55	40

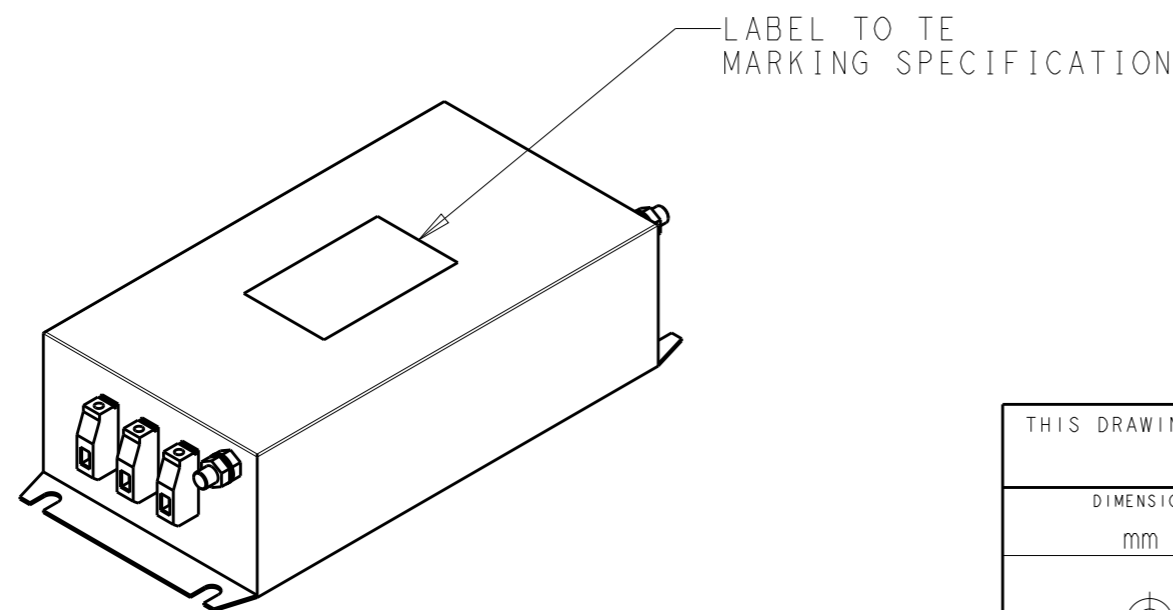

SAFETY ORGANIZATIONS

THIS FILTER WILL BE FORMALLY RECOGNIZED, CERTIFIED OR APPROVED BY THE LISTED AGENCY. THEREFORE, ALL TEST/REQUIREMENTS SPECIFIED IN THE LATEST REVISION OF THE FOLLOWING AGENCY STANDARDS WILL BE MET:

UL RECOGNIZED\* 100A 520V 50Hz/60Hz 40°C  
CSA CERTIFIED\*\* 100A 520V 50Hz/60Hz 40°C

\*31 JULY 2020 ; \*\*31 AUGUST 2020

OPERATING SPECIFICATION

LINE CURRENT/VOLTAGE: 100A, 520VAC  
LINE FREQUENCY: 50/60Hz

MAXIMUM LEAKAGE CURRENT: 20mA @ 230VAC, 50Hz

OPERATING AMBIENT TEMPERATURE RANGE @ RATED CURRENT: -25°C TO +40°C

IN AN AMBIENT, T<sub>a</sub>, HIGHER THAN 40°C, THE MAXIMUM OPERATING CURRENT, I<sub>o</sub>, IS AS FOLLOWS:

$$I_o = I_r \sqrt{\frac{85 - T_a}{45}}$$

RELIABILITY SPECIFICATIONS

STORAGE TEMPERATURE: -40°C TO +85°C  
HUMIDITY: 21 DAYS @ 40°C AND 95% RH

TEST SPECIFICATIONS

INDUCTANCE, NOMINAL: 0.1mH

CAPACITANCE @ 1kHz  
LINE TO GROUND, NOMINAL: 1.95μF  
LINE TO LINE, NOMINAL: 6.8μF

DISCHARGE RESISTOR

L/G I.R. 1MΩ 2W  
L/L I.R. 2MΩ 2W  
L/N I.R. XXX  
N/G I.R. XXX  
IR (NO DISCHARGE RESISTOR) 20°C, 50% RH AND 100VDC, MIN: 6MΩ

RECOMMENDED RECEIVING INSPECITON HIPOT

LINE TO GROUND FOR 1 MINUTE: 2856VDC  
LINE TO LINE FOR 1 MINUTE: 2236VDC

FILTER APPROVAL

THE BEST WAY TO SELECT AND QUALIFY A FILTER IS FOR YOUR ENGINEERING TO TEST THE UNIT IN YOUR EQUIPMENT.

THIS DRAWING IS A CONTROLLED DOCUMENT.		DWN 03MAR2020 SHRICHARANA B		
DIMENSIONS: mm		CHK 03MAR2020 LEO IRUDHAYARAJ		
TOLERANCES UNLESS OTHERWISE SPECIFIED:		APVD 03MAR2020 LEO IRUDHAYARAJ	NAME POWER LINE FILTER 100KEMS10BFPD	
0 PLC ±-		PRODUCT SPEC	SIZE	
1 PLC ±0.5		APPLICATION SPEC	CAGE CODE	
2 PLC ±0.40		WEIGHT	DRAWING NO	
3 PLC ±0.130		CUSTOMER DRAWING	RESTRICTED TO	
4 PLC ±0.0500		SCALE 1:4	SHEET 1 OF 2	
ANGLES ±-		REV B		
MATERIAL				
FINISH				

© 2020 TE Connectivity. All Rights Reserved.

REVISIONS

NOTE 1 GROUND CONNECTION:  
DO NOT LOOSEN INNER GROUND NUTS.  
TORQUE OUTER TERMINAL SCREWS: 2 Nm / 18 in lbs  
TORQUE GROUND NUTS: 4-10Nm

NOTE 2 INPUT OUTPUT CONNECTION TERMINAL  
AWG SIZE: 8-4 AWG  
WIRE SECTION: 25 mm<sup>2</sup>  
THREADED BOLT SIZE FOR GROUND: M10

P	LTR	DESCRIPTION	DATE	DWN	APVD
		SEE SHEET 1			

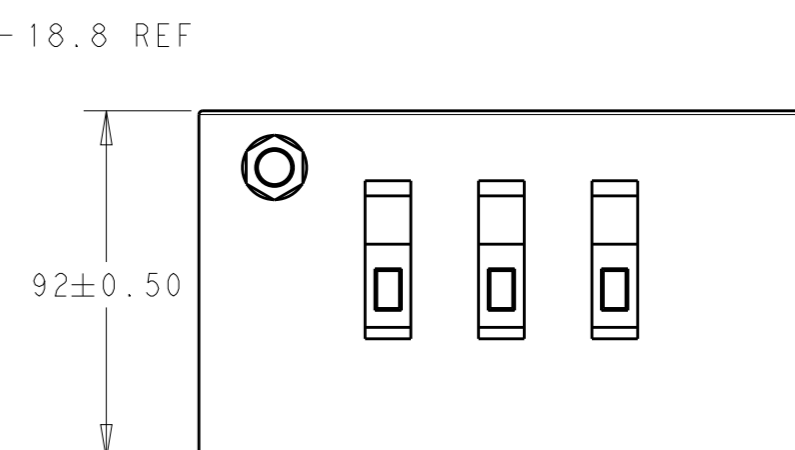
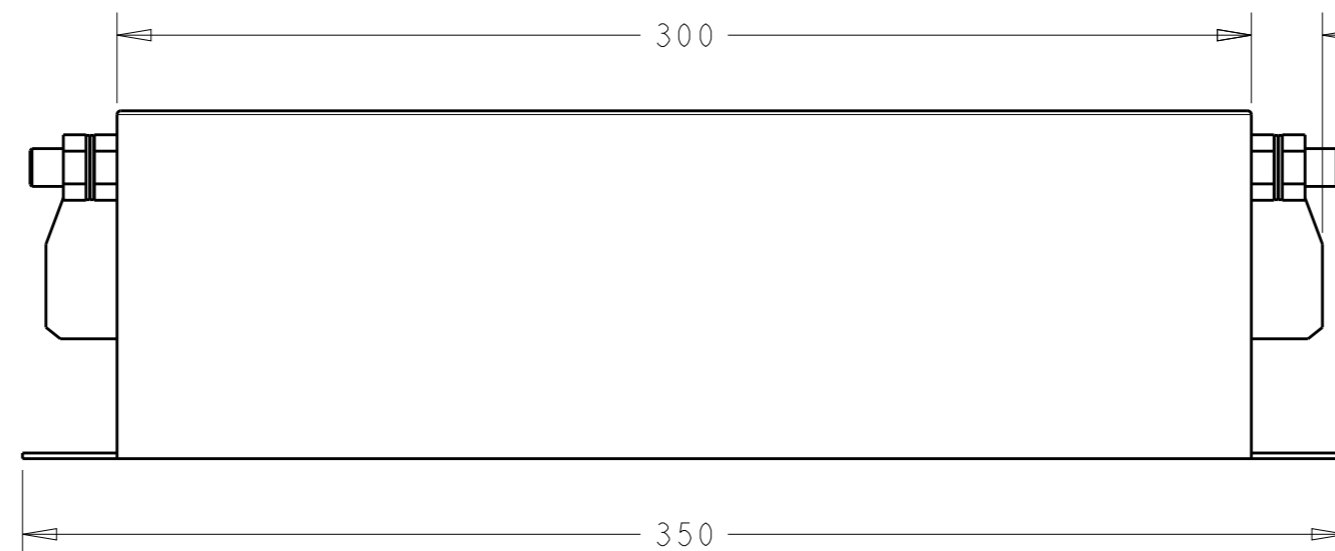
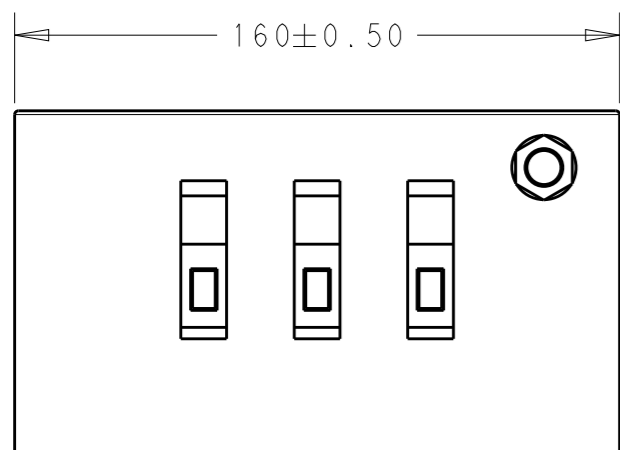
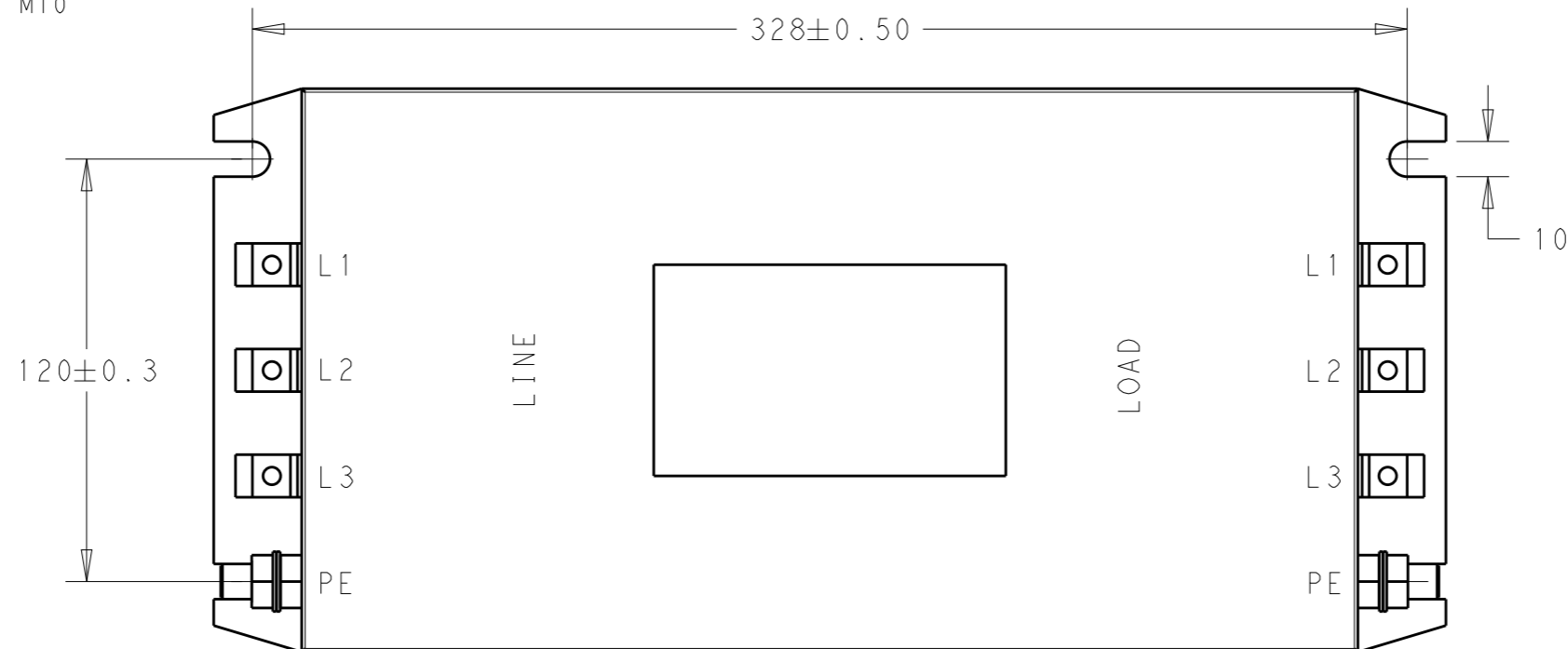

THIS DRAWING IS A CONTROLLED DOCUMENT.		DWN 03MAR2020 SHRICHARANA B														
DIMENSIONS: mm		CHK 03MAR2020 LEO IRUDHAYARAJ														
TOLERANCES UNLESS OTHERWISE SPECIFIED:		APVD 03MAR2020 LEO IRUDHAYARAJ	NAME POWER LINE FILTER 100KEMS10BFPD													
<table border="1"> <tr><td>0 PLC</td><td>±-</td></tr> <tr><td>1 PLC</td><td>±0.5</td></tr> <tr><td>2 PLC</td><td>±0.40</td></tr> <tr><td>3 PLC</td><td>±0.130</td></tr> <tr><td>4 PLC</td><td>±0.0500</td></tr> <tr><td>ANGLES</td><td>±-</td></tr> </table>		0 PLC	±-	1 PLC	±0.5	2 PLC	±0.40	3 PLC	±0.130	4 PLC	±0.0500	ANGLES	±-	PRODUCT SPEC -	RESTRICTED TO -	
0 PLC	±-															
1 PLC	±0.5															
2 PLC	±0.40															
3 PLC	±0.130															
4 PLC	±0.0500															
ANGLES	±-															
MATERIAL -		APPLICATION SPEC -	SIZE A3	CAGE CODE 00779	DRAWING NO G-5-1609967-2											
FINISH -		WEIGHT -	SCALE 1:2		SHEET 2 OF 2											
		CUSTOMER DRAWING	REV B													