

P	LTR	DESCRIPTION	DATE	DWN	APVD
	B	INITIAL RELEASE	07JUL2020	SR	LI

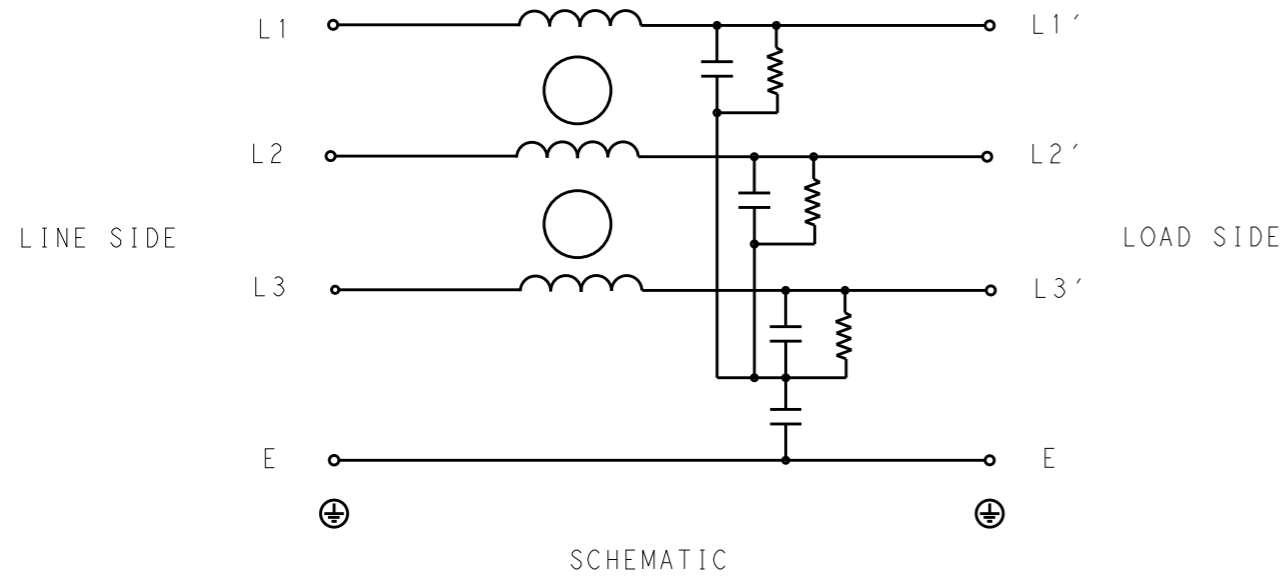

TYPICAL INSERTION LOSS
COMMON MODE 50/50Ω; DIFFERENTIAL MODE 50/50Ω

MHz	0.01	0.05	0.15	0.5	1	3	5	10	30
CM	2	2	5	12	18	25	32	40	45
DM	3	3	9	14	19	31	35	42	42

SAFETY ORGANIZATIONS

THIS FILTER WILL BE FORMALLY RECOGNIZED, CERTIFIED OR APPROVED BY THE LISTED AGENCY. THEREFORE, ALL TEST/REQUIREMENTS SPECIFIED IN THE LATEST REVISION OF THE FOLLOWING AGENCY STANDARDS WILL BE MET:

UL RECOGNIZED* 125A 520V 50Hz/60Hz 40°C

CSA CERTIFIED** 125A 520V 50Hz/60Hz 40°C

* 31 JULY 2020 ; ** 31 AUGUST 2020

OPERATING SPECIFICATION

LINE CURRENT/VOLTAGE: 125A, 520VAC

LINE FREQUENCY: 50/60Hz

MAXIMUM LEAKAGE CURRENT: 8mA @ 230VAC, 50Hz

OPERATING AMBIENT TEMPERATURE RANGE @ RATED CURRENT: -25°C TO +40°C

IN AN AMBIENT, T_a, HIGHER THAN 40°C, THE MAXIMUM OPERATING CURRENT, I_o, IS AS FOLLOWS:

$$I_o = I_r \sqrt{\frac{85 - T_a}{45}}$$

RELIABILITY SPECIFICATIONS

STORAGE TEMPERATURE: -40°C TO +85°C

HUMIDITY: 21 DAYS @ 40°C AND 95% RH

TEST SPECIFICATIONS

INDUCTANCE, NOMINAL: 0.1mH

CAPACITANCE @ 1kHz

LINE TO GROUND, NOMINAL: 98nF

LINE TO LINE, NOMINAL: 3.4μF

DISCHARGE RESISTOR

L/G I.R. 680KΩ 2W

L/L I.R. 2MΩ 2W

L/N I.R. XXX

N/G I.R. XXX

IR (NO DISCHARGE RESISTOR) 20°C, 50% RH AND 100VDC, MIN: 6MΩ

RECOMMENDED RECEIVING INSPECTION HIPOI

LINE TO GROUND FOR 1 MINUTE: 2856VDC

LINE TO LINE FOR 1 MINUTE: 2236VDC

FILTER APPROVAL

THE BEST WAY TO SELECT AND QUALIFY A FILTER IS FOR YOUR ENGINEERING TO TEST THE UNIT IN YOUR EQUIPMENT.

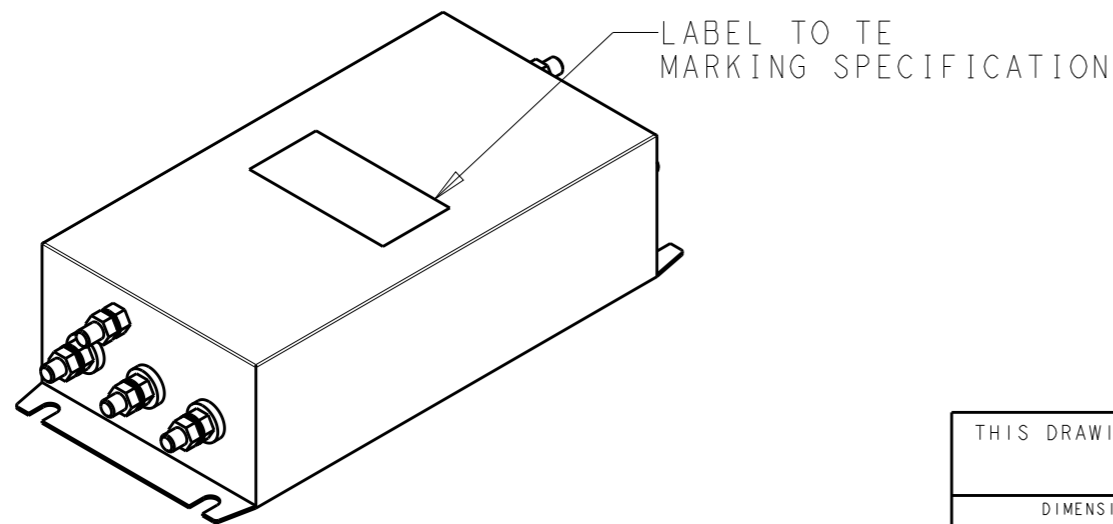

THIS DRAWING IS A CONTROLLED DOCUMENT.		DWN SUPREETH R 06FEB2020		
DIMENSIONS: mm		CHK LEO IRUDHAYARAJ 06FEB2020		
TOLERANCES UNLESS OTHERWISE SPECIFIED:		APVD LEO IRUDHAYARAJ 06FEB2020	NAME POWER LINE FILTER 125KEBS6BFPD	
0 PLC ±-		PRODUCT SPEC -	SIZE A3	
1 PLC ±0.5		APPLICATION SPEC -	CAGE CODE 00779	DRAWING NO C-5-1609965-4
2 PLC ±0.40		WEIGHT -	RESTRICTED TO -	
3 PLC ±0.130		CUSTOMER DRAWING	SCALE 1:4	SHEET 1 OF 2
4 PLC ±0.0500				REV B
ANGLES ±-				
MATERIAL -				
FINISH -				

© 2020 TE Connectivity. All Rights Reserved.

NOTE 1 GROUND CONNECTION:
DO NOT LOOSEN INNER GROUND NUTS.
TORQUE OUTER TERMINAL /GROUND NUTS: 4-10 Nm

NOTE 2 INPUT OUTPUT CONNECTION TERMINAL
AWG SIZE: XXX
THREADED BOLT SIZE FOR TERMINAL: M10
THREADED BOLT SIZE FOR GROUND: M10

REVISIONS

P	LTR	DESCRIPTION	DATE	DWN	APVD
		SEE SHEET 1			

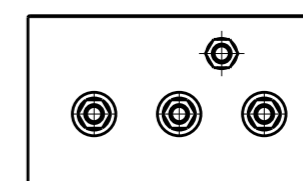
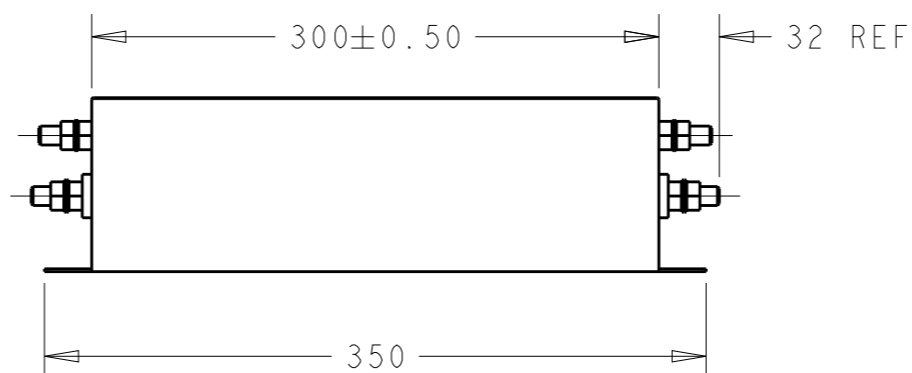
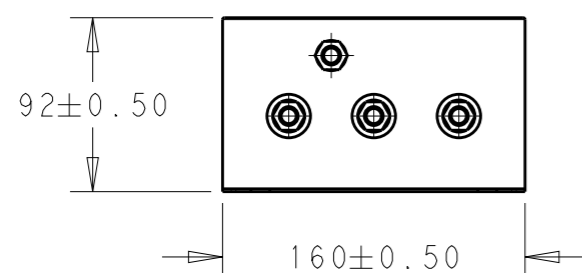
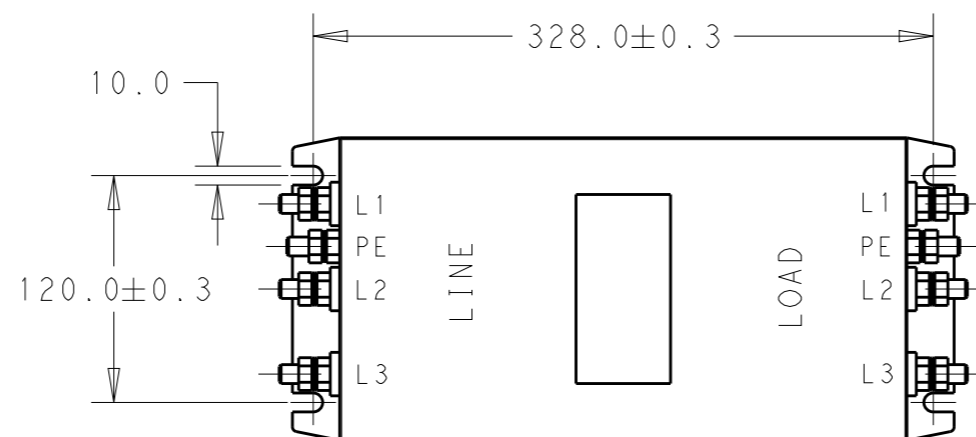

THIS DRAWING IS A CONTROLLED DOCUMENT.		DWN 06FEB2020 SUPREETH R														
DIMENSIONS: mm		CHK 06FEB2020 LEO IRUDHAYARAJ														
TOLERANCES UNLESS OTHERWISE SPECIFIED:		APVD 06FEB2020 LEO IRUDHAYARAJ	NAME POWER LINE FILTER 125KEBS6BFPD													
<table border="1"> <tr><td>0 PLC</td><td>±-</td></tr> <tr><td>1 PLC</td><td>±0.5</td></tr> <tr><td>2 PLC</td><td>±0.40</td></tr> <tr><td>3 PLC</td><td>±0.130</td></tr> <tr><td>4 PLC</td><td>±0.0500</td></tr> <tr><td>ANGLES</td><td>±-</td></tr> </table>		0 PLC	±-	1 PLC	±0.5	2 PLC	±0.40	3 PLC	±0.130	4 PLC	±0.0500	ANGLES	±-	PRODUCT SPEC -	RESTRICTED TO -	
0 PLC	±-															
1 PLC	±0.5															
2 PLC	±0.40															
3 PLC	±0.130															
4 PLC	±0.0500															
ANGLES	±-															
MATERIAL -		APPLICATION SPEC -	SIZE A3	CAGE CODE 00779	DRAWING NO C-5-1609965-4											
FINISH -		WEIGHT -	SCALE 1:4		SHEET 2 OF 2											
		CUSTOMER DRAWING	REV B													