

REVISIONS					
ZONE	LTR	ECN	DESCRIPTION	DATE	APPROVED
	A	23605	PROD. RELEASE	8/16/78	TED
	B	38872	UPDATE MAKING NOTE	3/1/99	JE
	C	39060	UPDATE REV. LETTER	6/16/99	JA

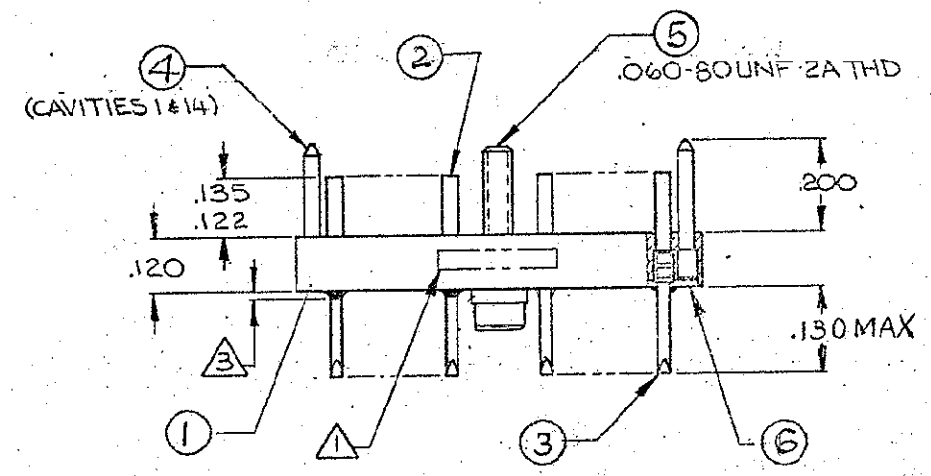
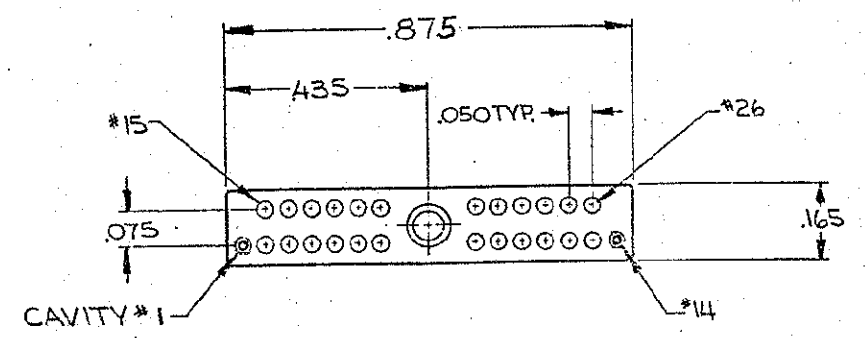

NOTES:
 △ MARKING AREA AS SHOWN, MARK PER TIS.

△ EPOXY WICKING → .050 MAX

A/R	EPOXY	HYSOL 4215 WITH 3561 CATALIST	6
1	JACKSCREW Ass'y	300 SERIES STAINLESS STEEL	5
2	GUIDE PIN	300 SERIES STAINLESS STEEL	4
24	SOLDER POT	COPPER ALLOY	3
24	CONTACT SOCKET	COPPER ALLOY	2
1	INSULATOR, SOCKET	6/10 NYLON COLOR BLUE	1

QTY REQD	DESCRIPTION	MATERIAL OR SPECIFICATION	ITEM NO
	PARTS LIST		
UNLESS OTHERWISE SPECIFIED DIMENSIONS ARE IN INCHES TOLERANCES ARE:		CONTRACT NO.	
FRACTIONS ±	DECIMALS .XX ± .01	APPROVALS DATE	
ANGLES ±	.XXX ± .005	DRAWN <i>Eunice</i> 8/15/78	
MATERIAL		CHECKED <i>(Signature)</i> 8/17/78	
FINISH		PR. ENG. <i>(Signature)</i> 8/17/78	
NEXT ASSY		APPD.	
USED ON		MALCO A MICRODOT COMPANY, INC. 220 PASADENA AVE., SO. PASADENA, CALIF. 91030	
APPLICATION		JACKMATE RECEPTACLE ASS'Y MCJB2-26SS	
DO NOT SCALE DRAWING		SIZE B	CODE IDENT NO. 98278 DRAWING NO. 095-0573-0302
		SCALE	PHOD. CODE 834 CODE CD SHEET 1 OF 1