

THIS DRAWING IS UNPUBLISHED. RELEASED FOR PUBLICATION 20
 © COPYRIGHT 20 BY - ALL RIGHTS RESERVED.

creo
 Creo Parametric 2.0
**DO NOT REVISE
 EXCEPT BY CAD**

REVISIONS				
P	LTR	DESCRIPTION	DATE	APVD
B		REVISED DRAWING ECO-15-013077	28OCT2015	NCL GOJ

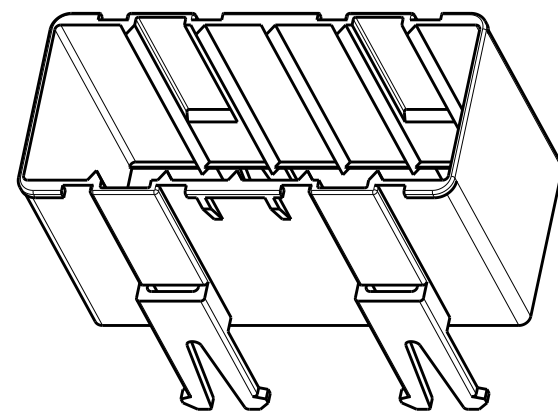
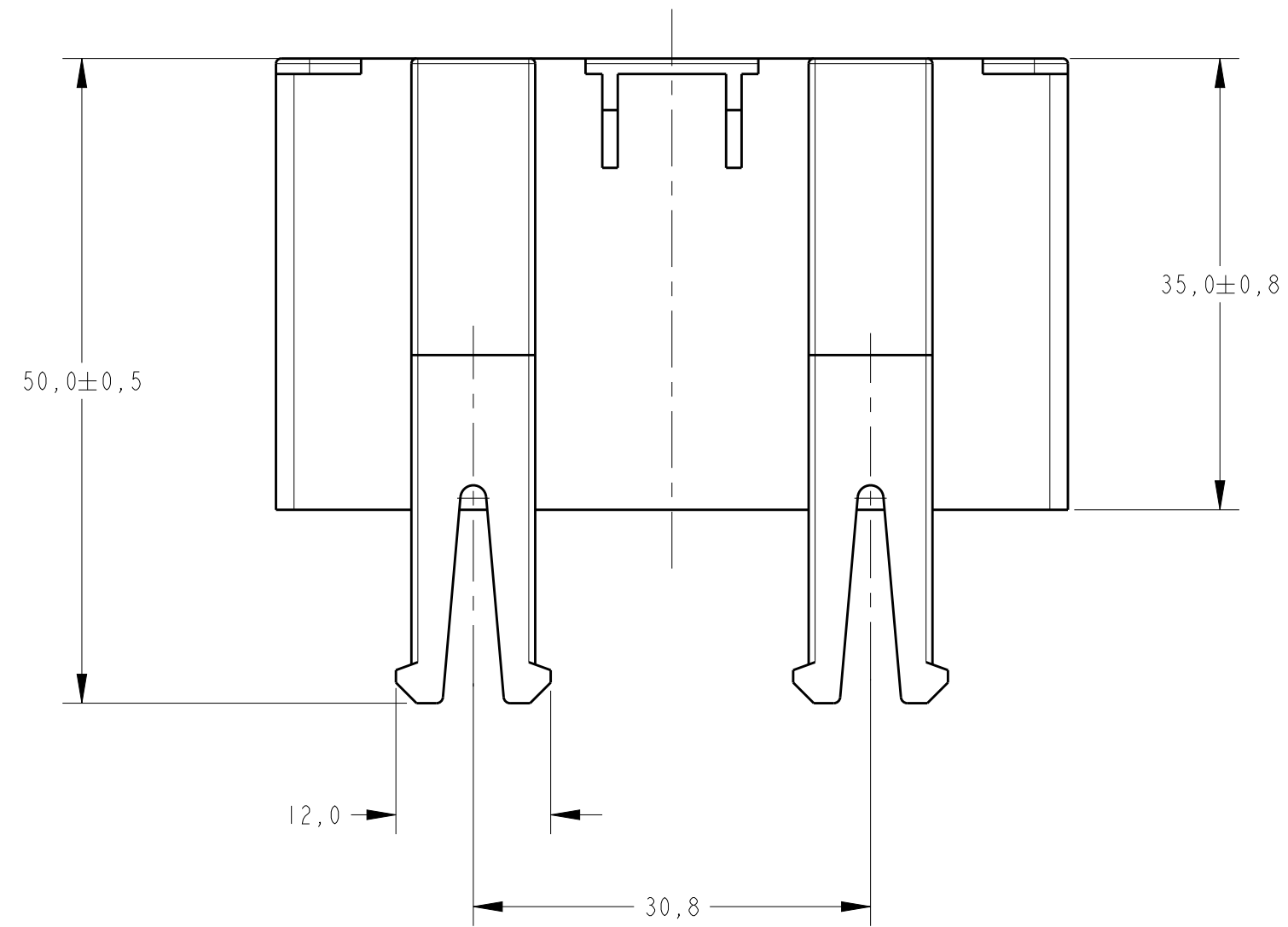
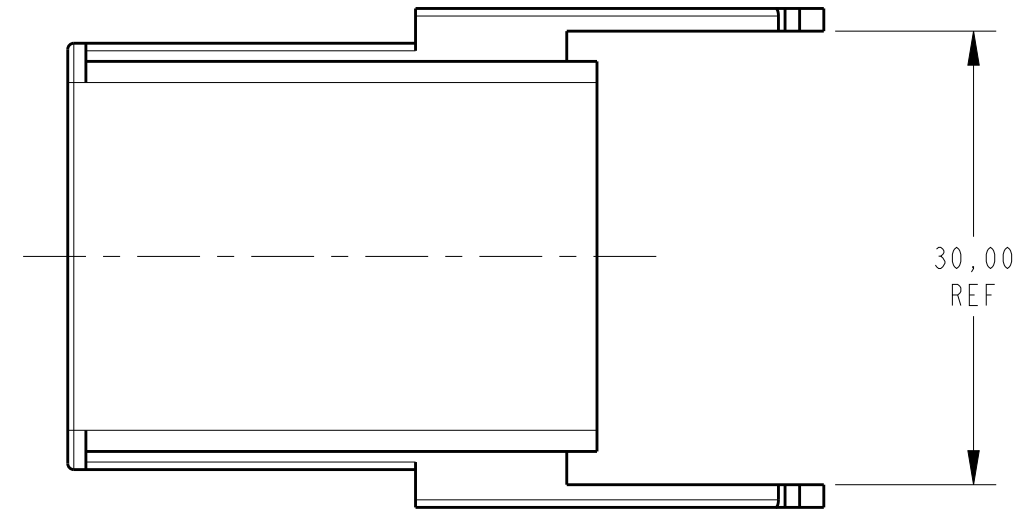
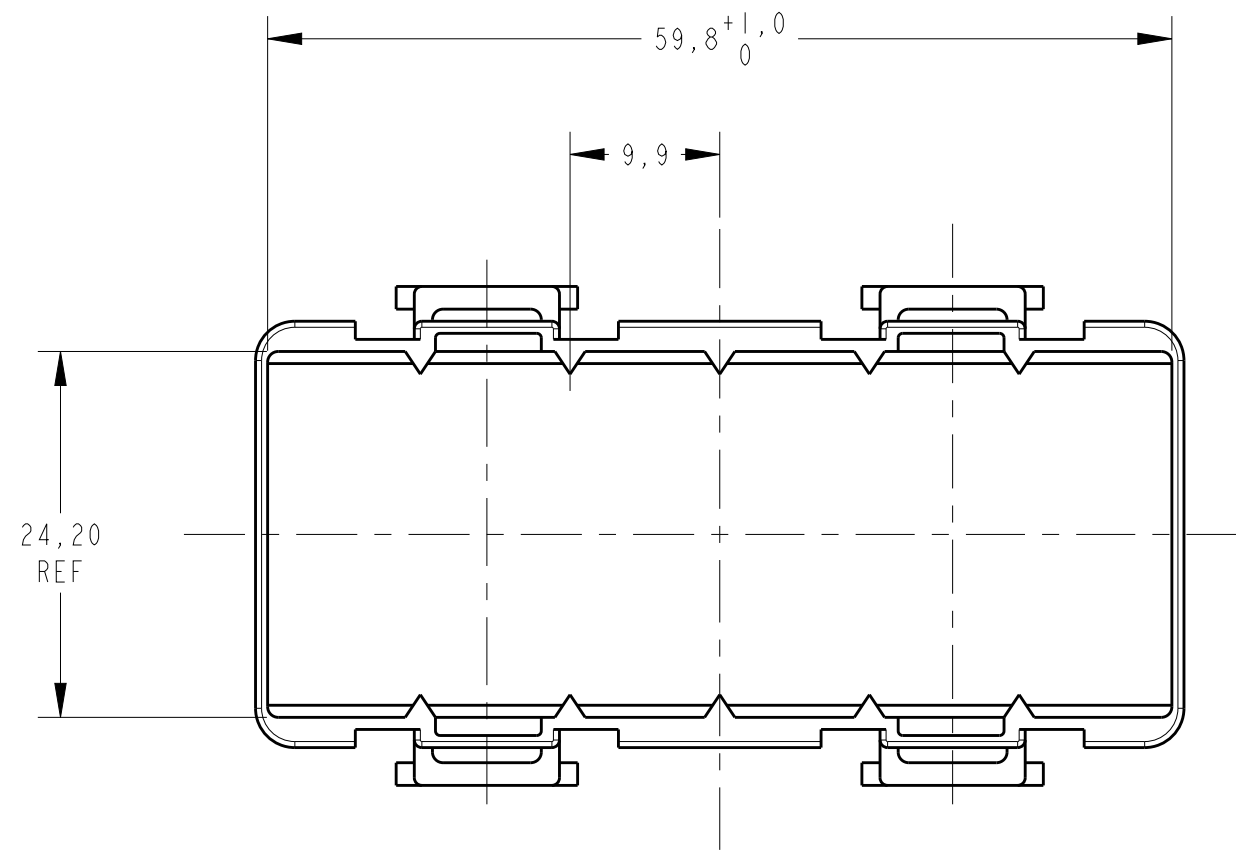

PERSPECTIVE VIEW
 SCALE 1:1

GRAVAÇÃO MARKING
LOGOTIPO AMP AMP LOGO
CÓDIGO PAÍS PRODUTOR MANUFACTURER COUNTRY CODE
NOMENCLATURA MATERIAL MATERIAL NOMENCLATURE
NÚMERO COMPONENTE TE TE COMPONENT NUMBER
NÚMERO CAVIDADE CAVITY NUMBER
REV+ LETRA REV.DA PEÇA REV.+ PART REV.LETTER

—	PRETO / BLACK	PA 6.6+15% FV/GF	493814-1
RAW MAT'L NO	FINISH	MATERIAL	PART NUMBER
THIS DRAWING IS A CONTROLLED DOCUMENT.		DWN M.R.BRIZ 06NOV98 CHK P.L.FARIA 01JUL99 APVD F.ALEXANDRONI 01JUL99	TE Connectivity COVER, 12 POSITIONS
DIMENSIONS: mm	TOLERANCES UNLESS OTHERWISE SPECIFIED: 0 PLC ± 1 PLC ±0.3 2 PLC ± 3 PLC ± 4 PLC ± ANGLES ± FINISH	PRODUCT SPEC APPLICATION SPEC WEIGHT	
MATERIAL SEE TABLE	SEE TABLE	Customer Drawing	A2 - C-493814 SCALE 2:1 SHEET 1 OF 1 REV B