

REVISIONS

P	LTR	DESCRIPTION	DATE	DWN	APVD
B		PRODUCTION ISSUE	30JAN2019	PNT	MT

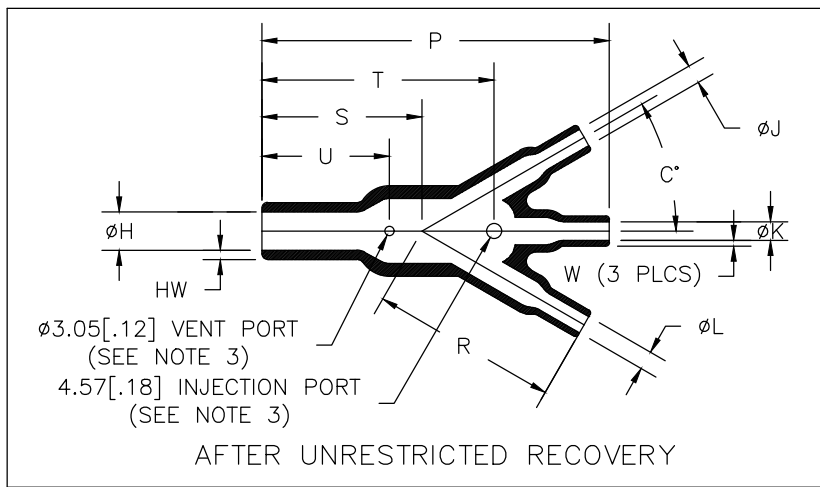
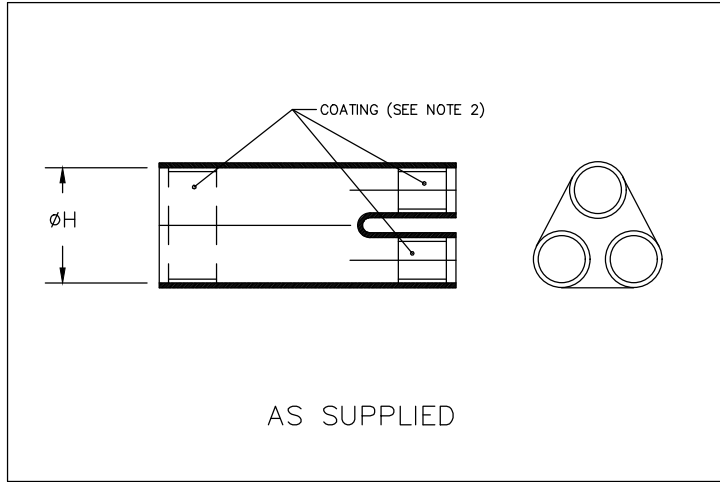

TABLE OF DIMENSIONS

PART NUMBER	H		J,K & L		P	R	S	T	U	HW	W	C
	Min a	Max b	Min a	Max b	$\pm 10\%$ b	$\pm 10\%$ b	$\pm 10\%$ b	$\pm 10\%$ b	$\pm 10\%$ b	$\pm 20\%$ b	$\pm 20\%$ b	$\pm 5^\circ$ b
462A011	13.2 [.52]	6.6 [.26]	6.6 [.26]	3.6 [.14]	46.2 [1.82]	25.4 [1.00]	20.8 [.82]	30.5 [1.20]	15.7 [.62]	1.52 [.06]	1.02 [.04]	30°
462A023	26.9 [1.06]	13.2 [.52]	13.2 [.52]	6.9 [.27]	93.2 [3.67]	50.3 [1.98]	42.9 [1.69]	57.2 [2.25]	33.0 [1.30]	2.54 [.10]	1.52 [.06]	30°
462A034	38.6 [1.52]	18.8 [.74]	19.3 [.76]	9.7 [.38]	135.1 [5.32]	73.7 [2.90]	61.5 [2.42]	88.9 [3.50]	45.7 [1.80]	3.05 [.12]	1.78 [.07]	30°
462A046	55.6 [2.19]	25.4 [1.00]	26.9 [1.06]	12.4 [.49]	192.0 [7.56]	103.1 [4.06]	88.9 [3.50]	121.9 [4.80]	71.1 [2.80]	4.57 [.18]	3.05 [.12]	30°

RELEASED FOR PUBLICATION

ALL RIGHTS RESERVED.

THIS DRAWING IS UNPUBLISHED.

© COPYRIGHT - TE Connectivity Ltd.

DIMENSIONS: mm [INCHES]	DWN	30JAN2019	MATERIAL	FINISH
	PRAVEEN N T		SEE SHEET 2	-
TOLERANCES UNLESS OTHERWISE SPECIFIED:	CHK	30JAN2019	 TE Connectivity Ltd.	
	N NAGAR			
0 PLC ± - 1 PLC ± - 2 PLC ± - 3 PLC ± - 4 PLC ± - ANGLES ± -	APVD	30JAN2019	NAME TRANSITION, 1 TO 3 CABLES	
	M TAYLOR			
WEIGHT	PRODUCT SPEC	-	SIZE	RESTRICTED TO
	APPLICATION SPEC	-	A4 00779	-
CUSTOMER DRAWING		DRAWING NO		SCALE
		462A011-25/225-0THRU046-25/225-0		DNS
				SHEET
				1 OF 2
				REV
				B

REVISIONS					
P	LTR	DESCRIPTION	DATE	DWN	APVD
	-	SEE SHEET 1	-	-	-

COMPATABILITY CHART				
MATERIAL DASH NO.	MATERIAL DESCRIPTION	RT SPEC	COATING SLASH NO.	COATING S NO.
-25	Elastomer, Fluid Resistant	RW-2070	/42; /86; /225	S1017;S1048;S1206

ORDERING INFORMATION

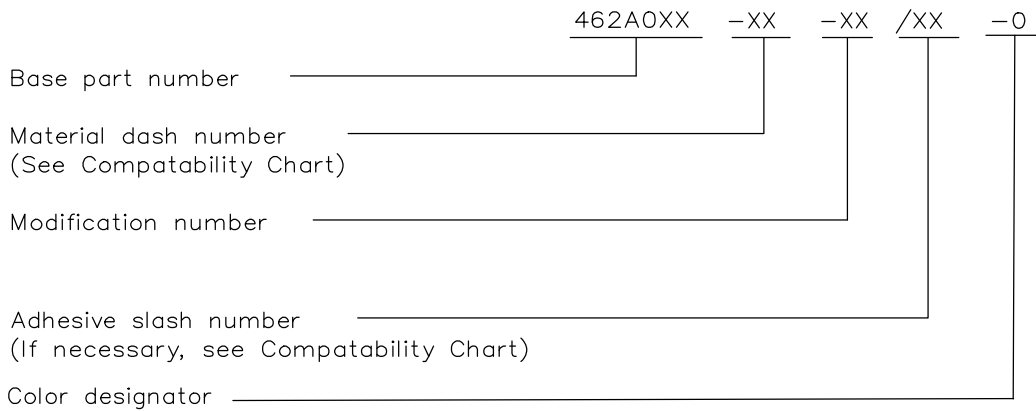

NOTES

- Dimensions appearing in table are as follows:
 - a - As Supplied
 - b - After Unrestricted Recovery
- Coating is optional. As supplied dimensions appearing in table are for uncoated parts. When coating is added, entry diameters will be reduced by 1.5mm[.06] max.
- Molding ports are optional. When -00 modification number is specified molding ports will be located as shown.

THIS DRAWING IS UNPUBLISHED. ALL RIGHTS RESERVED.

COPYRIGHT - TE Connectivity Ltd.

DIMENSIONS: mm [INCHES]	DWN PRAVEEN N T 30JAN2019	MATERIAL -	FINISH -
	CHK N NAGAR 30JAN2019	 TE Connectivity Ltd.	
TOLERANCES UNLESS OTHERWISE SPECIFIED:	APVD M TAYLOR 30JAN2019		
0 PLC ± -	PRODUCT SPEC -	SIZE A4	CAGE CODE 00779
1 PLC ± -	APPLICATION SPEC -	DRAWING NO G-462A011-25/225-0THRU046-25/225-0	RESTRICTED TO -
2 PLC ± -		CUSTOMER DRAWING	
3 PLC ± -		SCALE DNS	SHEET 2 OF 2
4 PLC ± -			REV B
ANGLES ± -			

