

THIS DRAWING IS UNPUBLISHED.

RELEASED FOR PUBLICATION

ALL RIGHTS RESERVED.

© COPYRIGHT - By -

LOC AF DIST 50

REVISIONS

P	LTR	DESCRIPTION	DATE	DWN	APVD
T1		REVISED PER ECR-20-009164	11AUG2020	MK	DH

1 CONTINUOUS STRIP ON REELS

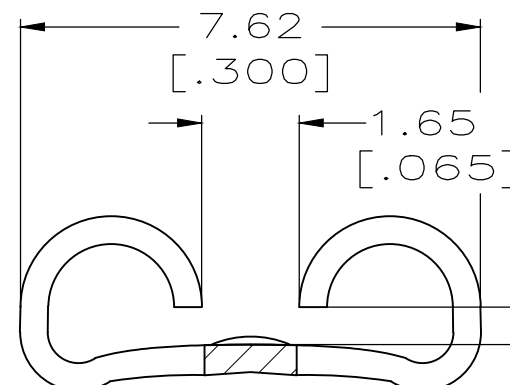
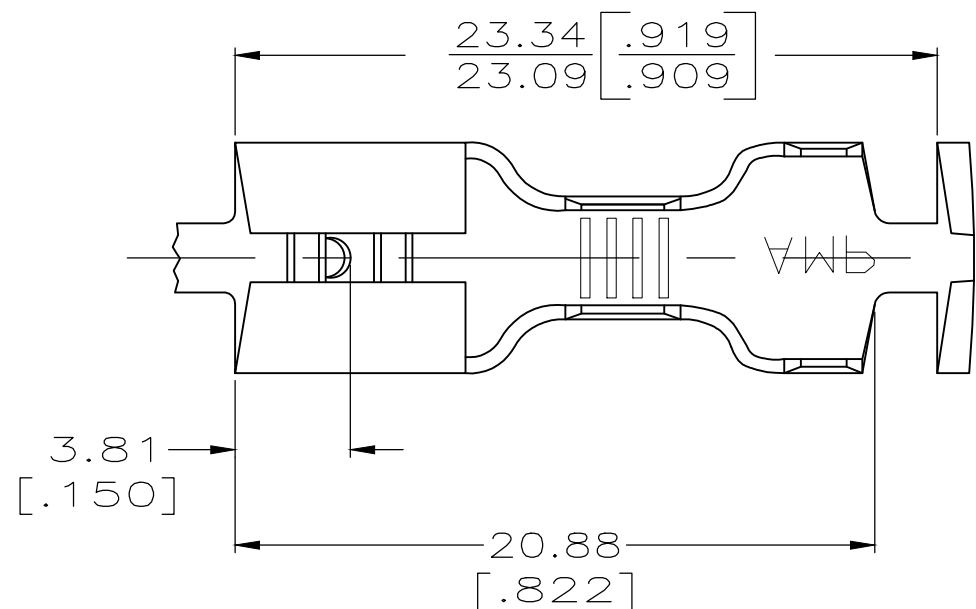

VIEW A-A
SCALE 8:1

GAP AS REQUIRED TO MEET FORCE SPECIFICATIONS AND 0.71 [.028] MAX

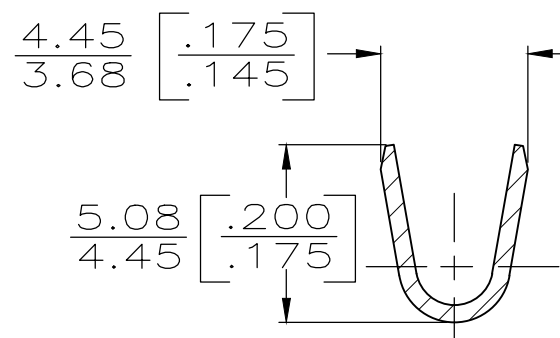
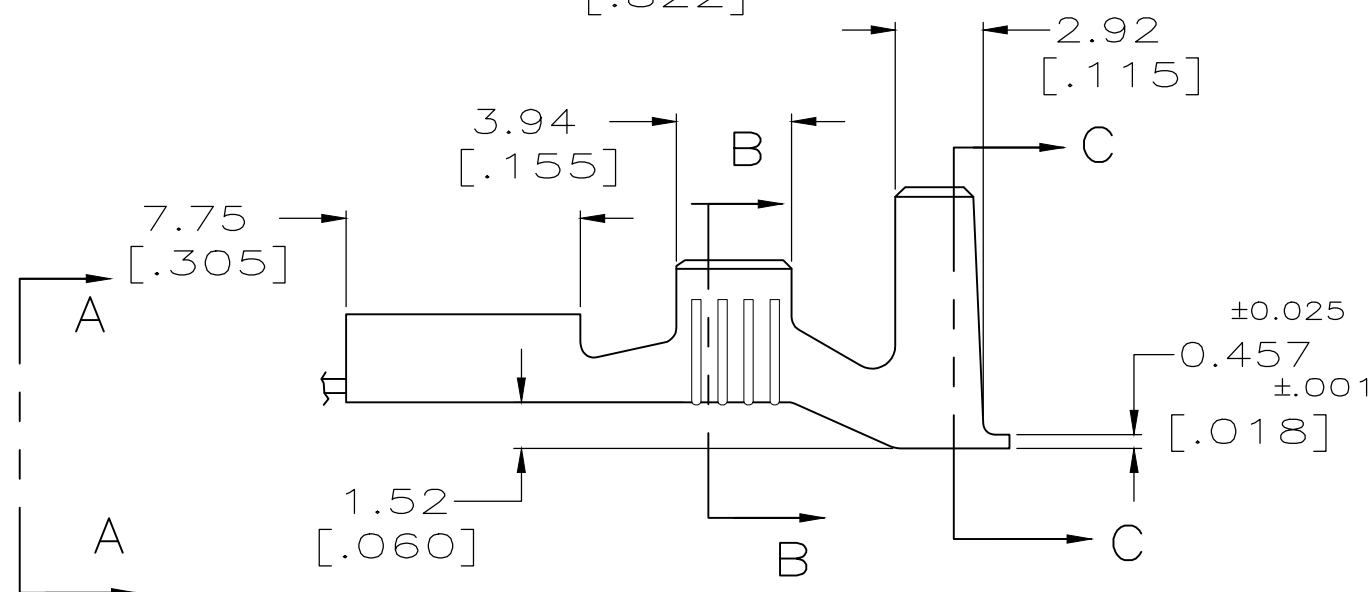

SECTION B-B
SCALE 5:1

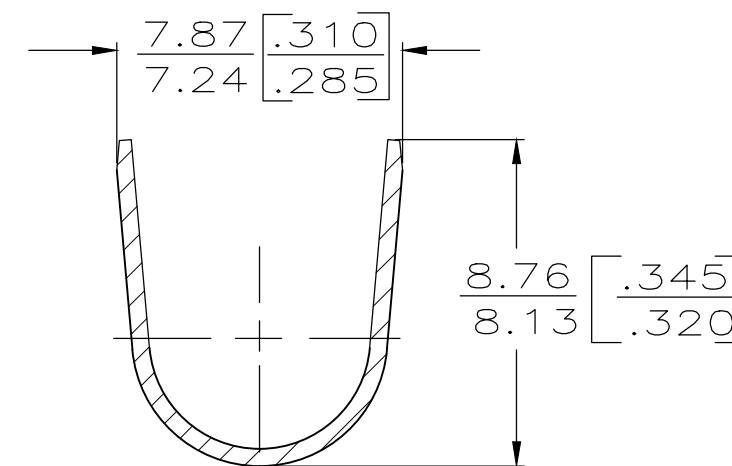

SECTION C-C
SCALE 5:1

5.33-6.73 or (2) 3.05 [.210-.265] or (2) [.120]	1.3-3.0mm ² or (2) 0.8mm ² [16-12] or (2) [#18's]	0.84-0.76 [.033-.030]	41728
INSULATION RANGE	WIRE SIZE	MATING TAB THK	PART NO.

THIS DRAWING IS A CONTROLLED DOCUMENT.		DWN JR RUTH 7/10/89	 TE Connectivity RECEPTACLE, FASTON, .250 SERIES	
DIMENSIONS: mm [INCHES]		CHK MS FEHER 7/10/89		
TOLERANCES UNLESS OTHERWISE SPECIFIED:		APVD R KUZO 7/10/89		
0 PLC ± - 1 PLC ± - 2 PLC ± - 3 PLC ± 0.38 [.015] 4 PLC ± - ANGLES ± -		NAME		
MATERIAL BRASS		FINISH TIN	PRODUCT SPEC -	APPLICATION SPEC -
		WEIGHT -	SIZE A3	CAGE CODE 00779
		CUSTOMER DRAWING	DRAWING NO C-41728	RESTRICTED TO -
		SCALE 4:1	SHEET 1 OF 1	REV T1