

N/C	3662-204-**-90	REVISIONS			
		REV	DESCRIPTION	DATE	APPROVED
N/C			NEW RELEASE PER E.O. C1603	4/21/94	<i>[Signature]</i>

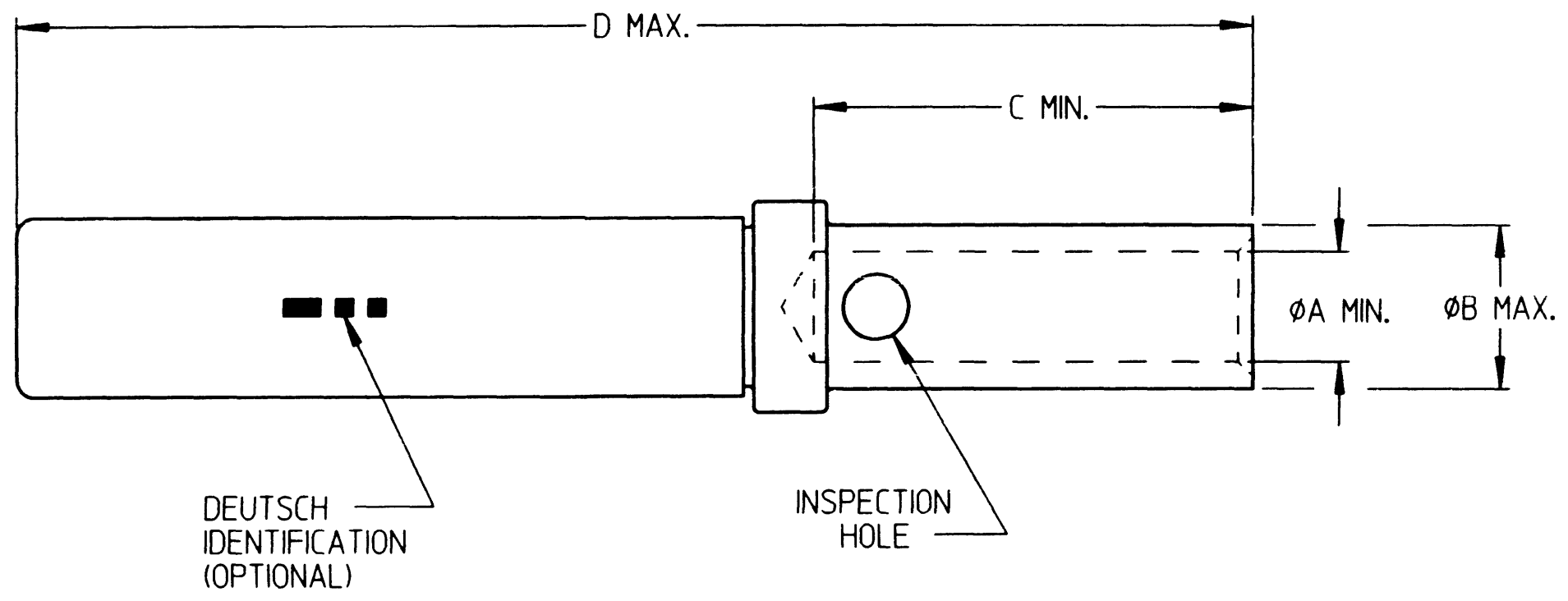

PART NUMBER **	TYPE	SIZE	ACCEPTABLE WIRE GAGE	RECOMMENDED STRIP LENGTH	ØA MIN.	ØB MAX.	C MIN.	D MAX.
3662-204-2090	SKT	20	20-24	.156 TO .219	.048	.078	.157	.656
3662-204-1690	SKT	16	16-20	.250 TO .313	.066	.103	.250	.759
3662-204-1290	SKT	12	12-14	.250 TO .313	.098	.151	.250	.759

4. CRIMP TOOL: M22520/1-01.
POSITIONER: M22520/1-02.
3. MATERIAL: BODY - COPPER ALLOY PER MIL-C-39029.
SLEEVE - STAINLESS STEEL.
2. FINISH: BODY - DEUTSCHCOAT V.
SLEEVE - PASSIVATED.
1. DIMENSIONS ARE IN INCHES UNLESS OTHERWISE SPECIFIED.

NOTE:

SIGNATURE & DATE	
DR	R. GROSS 3-14-94
CHK	<i>[Signature]</i> 4/21/94
PE	R. Gross 3-14-94
APPD	
SCALE	NONE WT —

CONTACT, SOCKET

MIL-C-39029/5 TYPE
WITH DEUTSCHCOAT V
LESS COLOR BANDS

ENVELOPE

CP	—	MATL CODE	—
DEUTSCH ENGINEERED CONNECTING DEVICES Municipal Airport Banning, California			
B	3662-204-**-90		
	DWG SIZE 11139	SHEET 1 OF 1	

3662-204-XX90_env_A