

Circuit

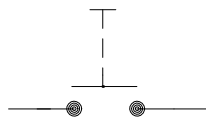

Technical Data:

Case Material	PA GF black
Switch Lever Material	PA GF red
Min. Insulation Resistance	100M0hm
Dielectric Withstanding Voltage	1050V-1min.
Max. Contact Drop during Resistive Load	150mV
Voltage	to 32VDC
Duty Rating	200A
Overload	500A-180sec.
	1000A-30sec.
Sealing	IP 67/ IEC 529
Vibration	4G / 50-2000Hz
Shock G-Level	6G / 11ms
Weight	~155g / 0.34 Pound
Temperature Range	-40°C to +85°C
Wire Section (at nominal Load)	min. 70mm ²
Switch Lever	removeable
Max. Torque (Main Contacts)	12-13Nm

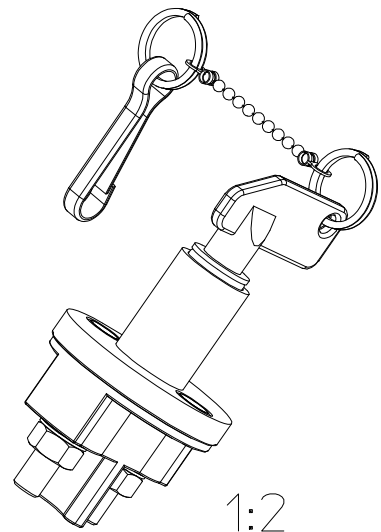

	Date	Name
Drawn	27.09.2018	Seege
Check	22.10.2018	Grind

mm ↔	Scale 1:1
General Tolerances DIN ISO 2768 cL	



Drawing No:	35-210-060-R
NSN:	