

REVISIONS					
P	LTR	DESCRIPTION	DATE	DWN	APVD
	B	PRODUCTION ISSUE	30JAN2019	PNT	MT

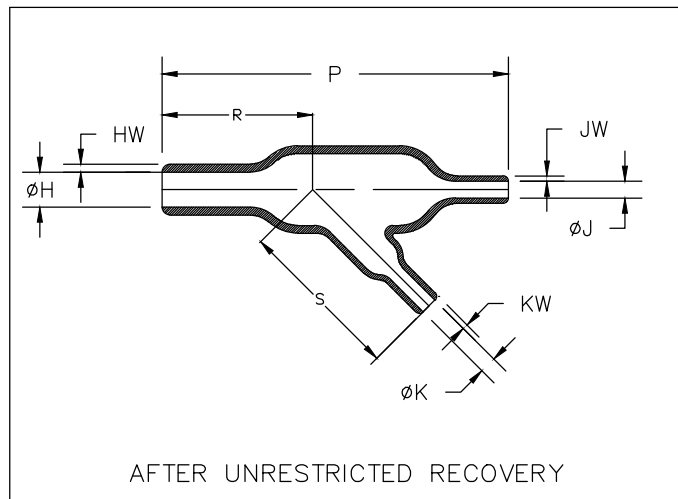
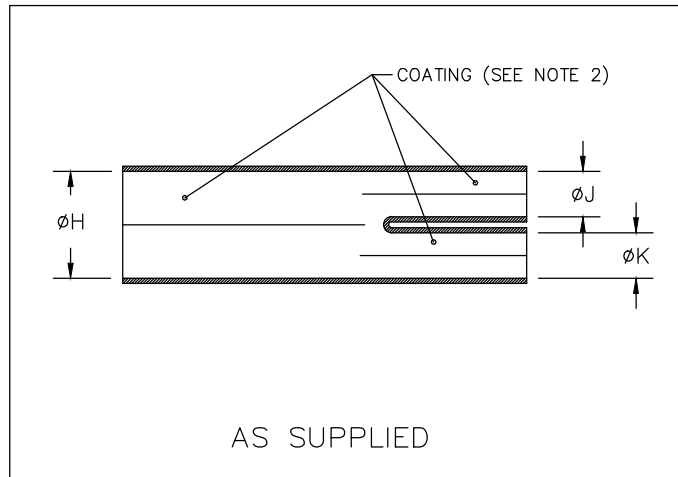

PART NUMBER	H		J & K		P	R	S	HW	JW & KW
	Min a	Max b	Min a	Max b	$\pm 10\%$ b	$\pm 10\%$ b	$\pm 10\%$ b	$\pm 20\%$ b	$\pm 20\%$ b
342A112-25/225	<u>13.2</u> [.52]	<u>6.1</u> [.24]	<u>6.6</u> [.26]	<u>3.0</u> [.12]	<u>44.7</u> [1.76]	<u>22.9</u> [.90]	<u>21.3</u> [.84]	<u>1.52</u> [.06]	<u>1.02</u> [.04]
342A124-25/225	<u>26.9</u> [1.06]	<u>12.4</u> [.49]	<u>13.2</u> [.52]	<u>6.1</u> [.24]	<u>89.9</u> [3.54]	<u>42.2</u> [1.66]	<u>42.7</u> [1.68]	<u>2.54</u> [.10]	<u>1.52</u> [.06]
342A138-25/225	<u>55.6</u> [2.19]	<u>25.4</u> [1.00]	<u>26.9</u> [1.06]	<u>12.4</u> [.49]	<u>183.1</u> [7.21]	<u>95.5</u> [3.76]	<u>86.4</u> [3.40]	<u>4.57</u> [.18]	<u>2.54</u> [.10]

RELEASED FOR PUBLICATION

ALL RIGHTS RESERVED.

THIS DRAWING IS UNPUBLISHED.

© COPYRIGHT - TE Connectivity Ltd.

DIMENSIONS: mm [INCHES]	DWN	30JAN2019	MATERIAL	SEE SHEET 2	FINISH	-									
	CHK	30JAN2019	 TE Connectivity Ltd.												
TOLERANCES UNLESS OTHERWISE SPECIFIED:	APVD	30JAN2019					NAME	TRANSITION, 45 DEGREES							
	PRODUCT SPEC	-	SIZE	A4	CAGE CODE	00779	DRAWING NO	C-342A1XX-25/225-0	RESTRICTED TO	-					
0 PLC ± -	1 PLC ± -	2 PLC ± -	3 PLC ± -	4 PLC ± -	ANGLES ± -	WEIGHT	CUSTOMER DRAWING			SCALE	DNS	SHEET	1 OF 2	REV	B

REVISIONS				
P	LTR	DESCRIPTION	DATE	APVD
	-	SEE SHEET 1	-	-

COMPATABILITY CHART				
MATERIAL DASH NO.	MATERIAL DESCRIPTION	RT SPEC	COATING SLASH NO.	COATING S NO.
-25	Elastomer, Fluid Resistant	RW-2070	/42; /86; /225	S1017; S1048; S1206

ORDERING INFORMATION

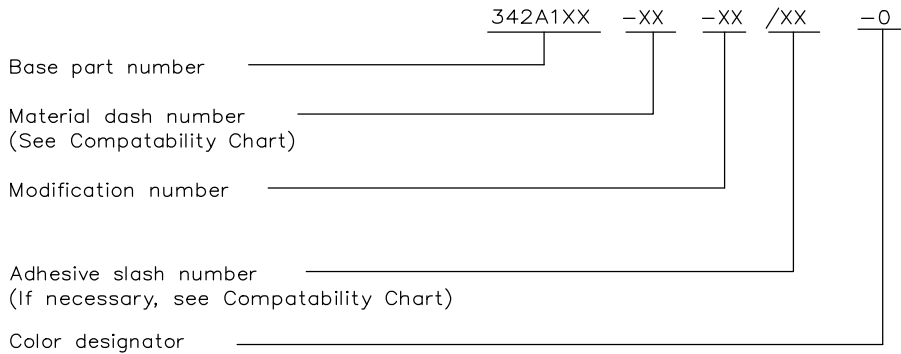

NOTES

- Dimensions appearing in table are as follows:
 - a - As Supplied
 - b - After Unrestricted Recovery
- Coating is optional. As supplied dimensions appearing in table are for uncoated parts. When coating is added, entry diameters will be reduced by 1.5mm[.06] max.

THIS DRAWING IS UNPUBLISHED. ALL RIGHTS RESERVED. © COPYRIGHT - TE Connectivity Ltd.

DIMENSIONS: mm [INCHES]	DWN PRAVEEN N T 30JAN2019	MATERIAL -	FINISH -
	CHK N NAGAR 30JAN2019	 TE Connectivity Ltd.	
TOLERANCES UNLESS OTHERWISE SPECIFIED:	APVD M TAYLOR 30JAN2019		
0 PLC ± -	PRODUCT SPEC -	SIZE A4	CAGE CODE 00779
1 PLC ± -	APPLICATION SPEC -	DRAWING NO C-342A1XX-25/225-0	RESTRICTED TO -
2 PLC ± -	WEIGHT	CUSTOMER DRAWING	
3 PLC ± -		SCALE DNS	SHEET 2 OF 2
4 PLC ± -			REV B
ANGLES ± -			

