

REVISIONS					
P	LTR	DESCRIPTION	DATE	DWN	APVD
AL2		REVISED AS PER ECR-24-199424	07FEB2024	NR	JK

- 1 TIN PER MIL-T-10727 OR TIN LEAD 0.00254 [.000100] MIN THK.
- 2 NICKEL UNDERPLATE ALL OVER, MATING SURFACE PLATED TO MEET PERFORMANCE REQUIREMENTS OF TE CONNECTIVITY PRODUCT SPECIFICATION 108-14008.
- 3 GOLD FLASH PER MIL-G-45204, TYPE II, 0.13-2.5µm [.000005-.000100] THK. OVER NICKEL PLATE PER QQ-N-290 0.51µm-1.52µm [.000020-.000060] EXT THK.
- 4 TIN PER MIL-T-10727 OR TIN LEAD 0.00381 [.000150] MIN THK.
- 5 RECOMMENDED HOLE SIZE, PLATED OR UNPLATED:
MACHINE INSERTION: 1.83^{+0.10}_{-0.08} [.072^{+0.004}_{-0.003}]
HAND INSERTION: 1.83^{+0.10}_{-0.00} [.072^{+0.004}_{-0.000}]
- 6 APPLICATION TOOL PART NUMBER: MACHINE NO. 682127-5
INSERTION HEAD NO. 682039-4
- 7 TO INSURE PROPER SPRING TENSION DO NOT EXCEED A 0.05 [.002] DIFFERENCE IN PIN DIA WHEN CHANGING TO A SMALLER PIN.
- 8 BOTTOM PLUG KNOCKOUT TOOL PART NUMBER 69729 WITH TIP PART NUMBER 69728-2.
- 9 MATERIAL: SPRING: BERYLLIUM COPPER (QQ-C-533)
EYELET: COPPER (QQ-C-576)

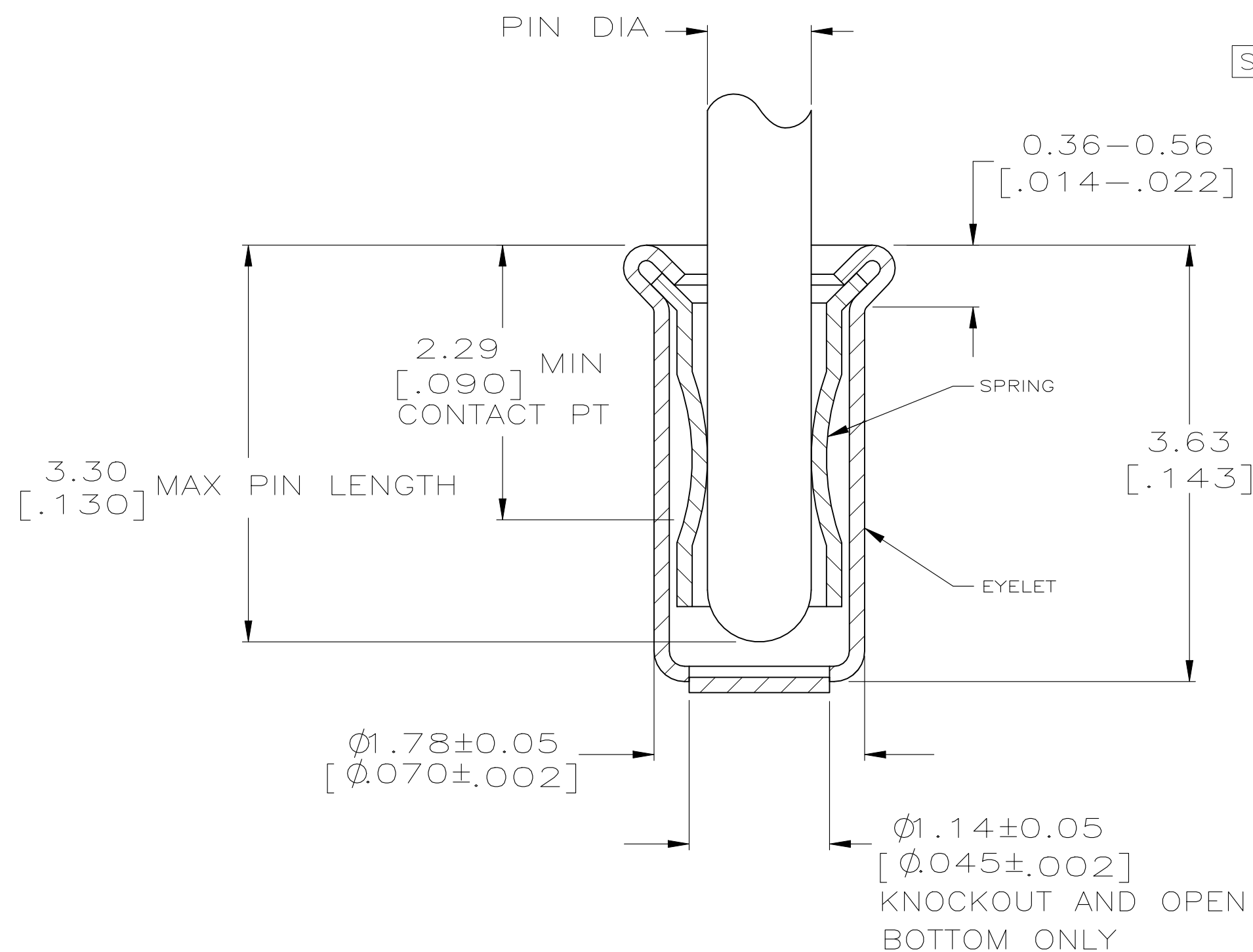
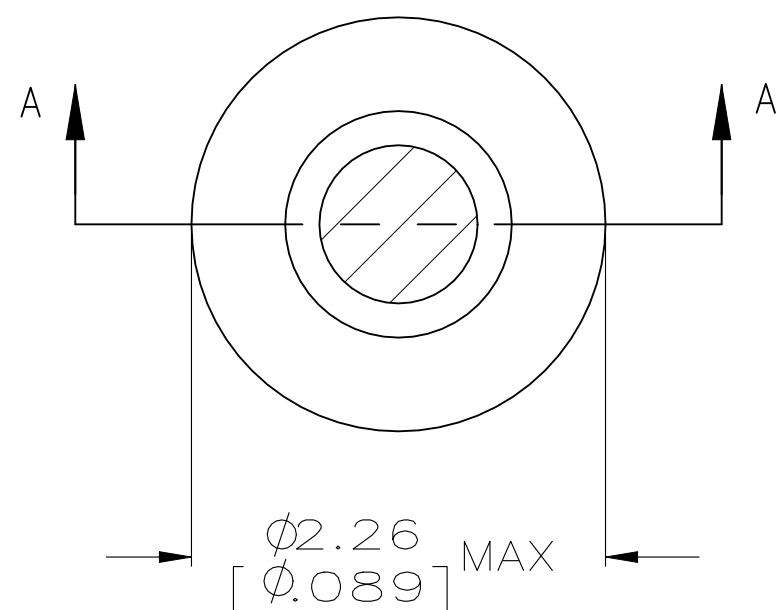

OBSOLETE	OPEN	0.71-0.84 [.028-.033]	TIN 1	GOLD 2	4-332070-4
		0.94-1.02 [.037-.040]		GOLD 2	4-332070-3
SUPSD BY 1-332070-9					
OBSOLETE	KNOCKOUT	0.94-1.02 [.037-.040]	TIN 1	GOLD 2	3-332070-5
OBSOLETE				TIN 1	3-332070-4
SUPSD BY 50865-1					
	KNOCKOUT	0.76-0.84 [.030-.033]		TIN 1	3-332070-0
OBSOLETE				GOLD 2	2-332070-9
OBSOLETE				TIN 1	2-332070-8
OBSOLETE	OPEN	0.86-0.94 [.034-.037]		GOLD 2	2-332070-7
OBSOLETE				TIN 1	2-332070-6
OBSOLETE				GOLD 2	2-332070-5
OBSOLETE				TIN 1	2-332070-4
OBSOLETE				GOLD 2	2-332070-3
OBSOLETE				TIN 1	2-332070-2
OBSOLETE	CLOSED	0.86-0.94 [.034-.037]		GOLD 2	2-332070-1
OBSOLETE				TIN 1	2-332070-0
OBSOLETE				GOLD 2	1-332070-9
OBSOLETE				TIN 1	1-332070-8
	KNOCKOUT	0.94-1.02 [.037-.040]			1-332070-7
					1-332070-4
	OPEN	0.86-0.94 [.034-.037]			1-332070-3
OBSOLETE				GOLD 3	1-332070-2
OBSOLETE				GOLD 2	1-332070-1
OBSOLETE	CLOSED	0.86-0.94 [.034-.037]			1-332070-0
OBSOLETE					332070
	BOTTOM TYPE	RECOMMENDED PIN DIA 7	EYELET	SPRING	PART NO
			FINISH		

THIS DRAWING IS A CONTROLLED DOCUMENT.

DIMENSIONS: mm [INCHES]	TOLERANCES UNLESS OTHERWISE SPECIFIED: 0 PLC ± - 1 PLC ± - 2 PLC ± - 3 PLC ± 0.20 [.008] 4 PLC ± - ANGLES ± -	DWN R. TALLEY 4-5-91 CHK R. MILLER 8-5-91 APVD S. ROBERTSON 8-22-91 PRODUCT SPEC APPLICATION SPEC	NAME MINIATURE SPRING SOCKET ASSEMBLY, SERIES 4
MATERIAL 9	FINISH SEE TABLE	WEIGHT 0.000000 CUSTOMER DRAWING	SIZE A2 CAGE CODE 00779 DRAWING NO C=332070 RESTRICTED TO -

TE Connectivity

SCALE 20:1 SHEET 1 OF 1 REV AL2