

© 1962 BY AMP INCORPORATED. ALL RIGHTS RESERVED. AMP PRODUCTS COVERED BY PATENTS AND/OR PATENTS PENDING.

328590

REVISIONS			
SYM	DESCRIPTION	DATE	APPD
A	ADDED 2-328590-2 PER NPS 66-1421	8/17/62	RHW
B	REVISED PER ECM PC-5578	LD 2/25/77	L.D.
C	INACTIVATE 328590 PER P9255	DBT 1-22-82	JLW
C1	REVISED PER ECO-09-026346	28NOV09	AEG

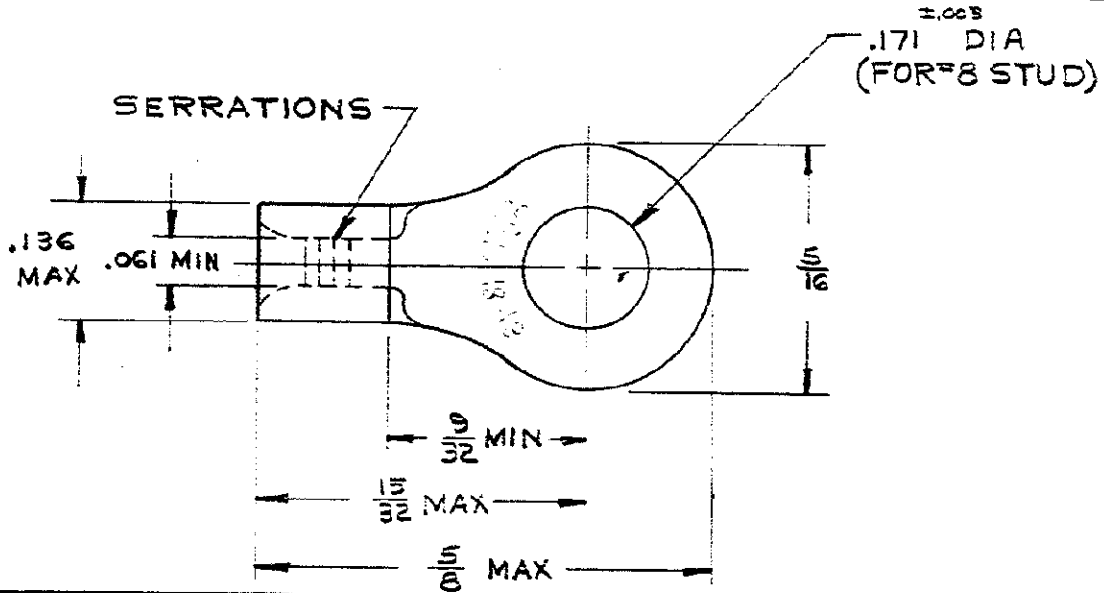

AMP INFO

LOC	PRINT	DIST
G	14	L

UNLESS OTHERWISE SPECIFIED DIMENSIONS ARE IN INCHES TOLERANCES ON		PART NO	FINISH	OBSOLETE
FRACTIONS = 1/64	DECIMALS = .008	328590	NOTE 1	
MATERIAL COPPER (60-40-576) .031 THK		2-328590-1	NOTE 2	
HEAT TREAT ANNEALED		NOTE: 1. GOLD PL (MIL-G-45204). 00005 MIN. EXT. THK. OVER NICKEL PL (QP-N-290). 00003 AVG. EXT. THK. 2. NICKEL PL (QP-N-290). 0003 AVG. EXT. THK.		
FINISH SEE TABLE				
SIGNATURE		AMP INCORPORATED HARRISBURG, PENNSYLVANIA		
DR <i>M. J. Sander</i>	DATE 8-29-62	 <p>WIRE TERMINAL SOLISTRAND RING TONGUE 18-16</p>		
CHK <i>J. Gillespie</i>	8/31/62			
DSGN ENGR				
APPD <i>J. Gillespie</i>	8/31/62			
DSGN APPD	CODE IDENT NO	SIZE	NUMBER	
	00779	A	328590	
OTHER APPD	SCALE	WT	CALC	ACTUAL
	4-1			SHEET 1 of 1